

## Features

- Core
  - ARM® Cortex™-M3 revision 2.0 running at up to 96 MHz
  - Memory Protection Unit (MPU)
  - Thumb®-2 instruction set
- Memories
  - From 64 to 256 Kbytes embedded Flash, 128-bit wide access, memory accelerator, dual bank
  - From 16 to 48 Kbytes embedded SRAM with dual banks
  - 16 Kbytes ROM with embedded bootloader routines (UART, USB) and IAP routines
  - Static Memory Controller (SMC): SRAM, NOR, NAND support. NAND Flash controller with 4-kbyte RAM buffer and ECC
- System
  - Embedded voltage regulator for single supply operation
  - POR, BOD and Watchdog for safe reset
  - Quartz or resonator oscillators: 3 to 20 MHz main and optional low power 32.768 kHz for RTC or device clock.
  - High precision 4/8/12 MHz factory trimmed internal RC oscillator and slow clock internal RC oscillator
  - One PLL for device clock and one dedicated PLL for USB 2.0 High Speed Device
  - Up to 19 peripheral DMA (PDC) channels and 4-channel central DMA
- Low Power Modes
  - Sleep and Backup modes, down to 2.5 µA in Backup mode.
  - Backup domain: VDDBU pin, RTC, 32 backup registers
  - Ultra low power RTC: 0.6 µA
- Peripherals
  - USB 2.0 Device: 480 Mbps, 4-kbyte FIFO, up to 7 bidirectional Endpoints, dedicated DMA
  - Up to 4 USARTs (ISO7816, IrDA®, Flow Control, SPI, Manchester support) and one UART
  - Up to 2 TWI (I2C), 1 SPI, 1 SSC (I2S), 1 HSMCI (SDIO/SD/MMC)
  - 3-Channel 16-bit Timer/Counter (TC) for capture, compare and PWM
  - 4-channel 16-bit PWM (PWMC)
  - 32-bit Real Time Timer (RTT) and RTC with calendar and alarm features
  - 8-channel 12-bit 1Msps ADC with differential input mode and programmable gain stage, 8-channel 10-bit ADC
- I/O
  - Up to 96 I/O lines with external interrupt capability (edge or level sensitivity), debouncing, glitch filtering and on-die Series Resistor Termination
  - Three 32-bit Parallel Input/Outputs (PIO)
- Packages
  - 100-lead LQFP, 14 x 14 mm, pitch 0.5 mm
  - 100-ball LFBGA, 9 x 9 mm, pitch 0.8 mm
  - 144-lead LQFP, 20 x 20 mm, pitch 0.5 mm
  - 144-ball LFBGA, 10 x 10 mm, pitch 0.8 mm



## AT91ARM M3 Cortex-based Processor

## ATSAM3U Series

## Preliminary

## Summary

**NOTE:** This is a summary document.  
The complete document is available on  
the Atmel website at [www.atmel.com](http://www.atmel.com).

6430AS-ATARM-29-May-09



# 1. SAM3U Description

Atmel's SAM3U series is a member of a family of Flash microcontrollers based on the high performance 32-bit ARM Cortex-M3 RISC processor. It operates at a maximum speed of 96 MHz and features up to 256 Kbytes of Flash and up to 48 Kbytes of SRAM. The peripheral set includes a High Speed USB Device port with embedded transceiver, a High Speed MCI for SDIO/SD/MMC, an External Bus Interface with NAND Flash controller, 4x USARTs, 2x TWIs, 1x SPI, as well as 1 PWM timer, 3x general purpose 16-bit timers, an RTC, a 12-bit ADC and a 10-bit ADC.

The SAM3U architecture is specifically designed to sustain high speed data transfers. It includes a multi-layer bus matrix as well as multiple SRAM banks, PDC and DMA channels that enable it to run tasks in parallel and maximize data throughput.

It can operate from 1.62V to 3.6V and comes in 100-pin and 144-pin LQFP and BGA packages.

The SAM3U device is particularly well suited for USB applications: data loggers, PC peripherals and any high speed bridge (USB to SDIO, USB to SPI, USB to External Bus Interface).

## 1.1 Configuration Summary

The SAM3U series differ in memory sizes, package and features list. [Table 1-1](#) summarizes the configurations of the six devices.

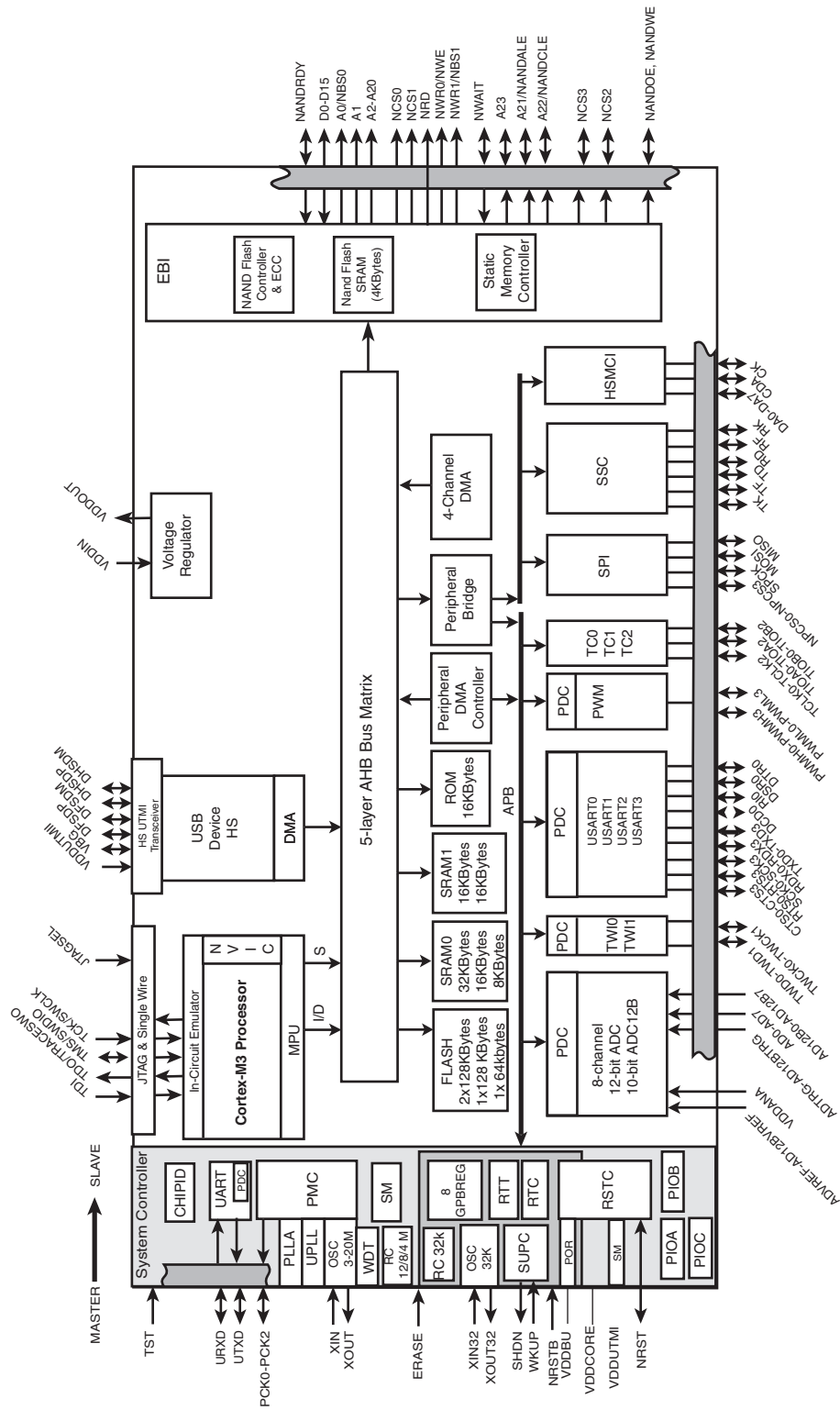
**Table 1-1.** Configuration Summary

Device	Flash	Flash Organization	SRAM	Number of PIOs	Number of USARTs	Number of TWI	FWUP, SHDN pins	External Bus Interface	HSMCI data size	Package	ADC
SAM3U4E	2x 128 Kbytes	dual plane	52 Kbytes	96	4	2	Yes	8 or 16 bits, 4 chip selects, 24-bit address	8 bits	LQFP144 BGA144	2 (8+ 8 channels)
SAM3U2E	128 Kbytes	single plane	36 Kbytes	96	4	2	Yes	8 or 16 bits, 4 chip selects 24-bit address	8 bits	LQFP144 BGA144	2 (8+ 8 channels)
SAM3U1E	64 Kbytes	single plane	20 Kbytes	96	4	2	Yes	8 or 16 bits, 4 chip selects, 24-bit address	8 bits	LQFP144 BGA144	2 (8+ 8 channels)
SAM3U4C	2 x 128 Kbytes	dual plane	52 Kbytes	57	3	1	No	8, 2 chip selects, 8-bit address	4 bits	LQFP100 BGA100	2 (4+ 4 channels)
SAM3U2C	128 Kbytes	single plane	36 Kbytes	57	3	1	No	8, 2 chip selects, 8-bit address	4 bits	LQFP100 BGA100	2 (4+ 4 channels)
SAM3U1C	64 Kbytes	single plane	20 Kbytes	57	3	1	No	8, 2 chip selects, 8-bit address	4 bits	LQFP100 BGA100	2 (4+ 4 channels)

Note: 1. The SRAM size takes into account the 4 Kbytes RAM buffer of the NAND Flash Controller (NFC) which can be used by the core if not used by the NFC.

## 2. SAM3U Block Diagram

Figure 2-1. 144-pin SAM3U Block Diagram





## 3. Signal Description

Table 3-1 gives details on the signal names classified by peripheral.

Table 3-1. Signal Description List

Signal Name	Function	Type	Active Level	Voltage Reference	Comments
<b>Power Supplies</b>					
VDDIO	Peripherals I/O Lines Power Supply	Power			1.62V to 3.6V
VDDUTMII	USB UTMI+ Interface Power Supply	Power			3.0V to 3.6V
GNDUTMII	USB UTMI+ Interface Ground	Ground			
VDDBU	Backup I/O Lines Power Supply	Power			1.62V to 3.6V
GNDDBU	Backup Ground	Ground			
VDDPLL	PLL A, UPLL and OSC 3-20 MHz Power Supply	Power			1.62 V to 1.95V
GNDPLL	PLL A, UPLL and OSC 3-20 MHz Ground	Ground			
VDDANA	ADC Analog Power Supply	Power			2.4V to 3.6V
GNDANA	ADC Analog Ground	Ground			
VDDCORE	Core Chip Power Supply	Power			1.62V to 1.95V
GND	Ground	Ground			
<b>Clocks, Oscillators and PLLs</b>					
XIN	Main Oscillator Input	Input		VDDPLL	
XOUT	Main Oscillator Output	Output			
XIN32	Slow Clock Oscillator Input	Input		VDDBU	
XOUT32	Slow Clock Oscillator Output	Output			
VBG	Bias Voltage Reference	Analog			
PCK0 - PCK2	Programmable Clock Output	Output			
<b>Shutdown, Wakeup Logic</b>					
SHDN	Shut-Down Control	Output		VDDBU	push/pull 0: The device is in backup mode 1: The device is running (not in backup mode)
FWUP	Force Wake-Up Input	Input	Low	VDDBU	Needs external Pull-up
<b>ICE and JTAG</b>					
TCK	Test Clock	Input		VDDIO	No pull-up resistor
TDI	Test Data In	Input		VDDIO	No pull-up resistor
TDO	Test Data Out	Output		VDDIO	
TRACESWO	Trace Asynchronous Data Out	Output		VDDIO	
SWDIO	Serial Wire Input/Output	I/O		VDDIO	
SWCLK	Serial Wire Clock	Input		VDDIO	
TMS	Test Mode Select	Input		VDDIO	No pull-up resistor
JTAGSEL	JTAG Selection	Input	High	VDDBU	Pull-down resistor



**Table 3-1.** Signal Description List (Continued)

Signal Name	Function	Type	Active Level	Voltage Reference	Comments
<b>Flash Memory</b>					
ERASE	Flash and NVM Configuration Bits Erase Command	Input	High	VDDBU	Pull-down (15 kΩ) resistor
<b>Reset/Test</b>					
NRST	Microcontroller Reset	I/O	Low	VDDIO	Pull-Up resistor
NRSTB	Asynchronous Microcontroller Reset	Input	Low	VDDBU	Pull-Up resistor
TST	Test Select	Input		VDDBU	Pull-down resistor
<b>Universal Asynchronous Receiver Transceiver - UART</b>					
URXD	UART Receive Data	Input			
UTXD	UART Transmit Data	Output			
<b>PIO Controller - PIOA - PIOB - PIOC</b>					
PA0 - PA31	Parallel IO Controller A	I/O		VDDIO	Pulled-up input at reset
PB0 - PB31	Parallel IO Controller B	I/O		VDDIO	Pulled-up input at reset
PC0 - PC31	Parallel IO Controller C	I/O		VDDIO	Pulled-up input at reset
<b>External Bus Interface</b>					
D0 - D15	Data Bus	I/O			Pulled-up input at reset
A0 - A23	Address Bus	Output			
NWAIT	External Wait Signal	Input	Low		
<b>Static Memory Controller - SMC</b>					
NCS0 - NCS3	Chip Select Lines	Output	Low		
NWR0 - NWR1	Write Signal	Output	Low		
NRD	Read Signal	Output	Low		
NWE	Write Enable	Output	Low		
NBS0 - NBS1	Byte Mask Signal	Output	Low		
<b>NAND Flash Controller - NFC</b>					
NANDOE	NAND Flash Output Enable	Output	Low		
NANDWE	NAND Flash Write Enable	Output	Low		
NANDRDY	NAND Ready	Input			
<b>High Speed Multimedia Card Interface - HSMCI</b>					
CK	Multimedia Card Clock	I/O			
CDA	Multimedia Card Slot A Command	I/O			
DA0 - DA7	Multimedia Card Slot A Data	I/O			

**Table 3-1.** Signal Description List (Continued)

Signal Name	Function	Type	Active Level	Voltage Reference	Comments
<b>Universal Synchronous Asynchronous Receiver Transmitter - USARTx</b>					
SCKx	USARTx Serial Clock	I/O			
TXDx	USARTx Transmit Data	I/O			
RXDx	USARTx Receive Data	Input			
RTSx	USARTx Request To Send	Output			
CTSx	USARTx Clear To Send	Input			
DTR0	USART0 Data Terminal Ready	I/O			
DSR0	USART0 Data Set Ready	Input			
DCD0	USART0 Data Carrier Detect	Output			
RI0	USART0 Ring Indicator	Input			
<b>Synchronous Serial Controller - SSC</b>					
TD	SSC Transmit Data	Output			
RD	SSC Receive Data	Input			
TK	SSC Transmit Clock	I/O			
RK	SSC Receive Clock	I/O			
TF	SSC Transmit Frame Sync	I/O			
RF	SSC Receive Frame Sync	I/O			
<b>Timer/Counter - TC</b>					
TCLKx	TC Channel x External Clock Input	Input			
TIOAx	TC Channel x I/O Line A	I/O			
TIOBx	TC Channel x I/O Line B	I/O			
<b>Pulse Width Modulation Controller- PWMC</b>					
PWMHx	PWM Waveform Output High for channel x	Output			
PWMLx	PWM Waveform Output Low for channel x	Output			only output in complementary mode when dead time insertion is enabled
PWMFI0-2	PWM Fault Input	Input			
<b>Serial Peripheral Interface - SPI</b>					
MISO	Master In Slave Out	I/O			
MOSI	Master Out Slave In	I/O			
SPCK	SPI Serial Clock	I/O			
NPCS0	SPI Peripheral Chip Select 0	I/O	Low		
NPCS1 - NPC3	SPI Peripheral Chip Select	Output	Low		
<b>Two-Wire Interface - TWI</b>					
TWDx	TWix Two-wire Serial Data	I/O			
TWCKx	TWix Two-wire Serial Clock	I/O			

**Table 3-1.** Signal Description List (Continued)

Signal Name	Function	Type	Active Level	Voltage Reference	Comments
<b>12-bit Analog-to-Digital Converter - ADC12B</b>					
AD12Bx	Analog Inputs	Analog			
AD12BTRG	ADC Trigger	Input			
AD12BVREF	ADC Reference	Analog			
<b>10-bit Analog-to-Digital Converter - ADC</b>					
ADx	Analog Inputs	Analog			
ADTRG	ADC Trigger	Input			
ADVREF	ADC Reference	Analog			
<b>Fast Flash Programming Interface - FFPI</b>					
PGMEN0-PGMEN2	Programming Enabling	Input		VDDIO	
PGMM0-PGMM3	Programming Mode	Input		VDDIO	
PGMD0-PGMD15	Programming Data	I/O		VDDIO	
PGMRDY	Programming Ready	Output	High	VDDIO	
PGMNVALID	Data Direction	Output	Low	VDDIO	
PGMNOE	Programming Read	Input	Low	VDDIO	
PGMCK	Programming Clock	Input		VDDIO	
PGMNCMD	Programming Command	Input	Low	VDDIO	
<b>USB High Speed Device - UDPHS</b>					
DFSDM	USB Device Full Speed Data -	Analog		VDDUTMII	
DFSDP	USB Device Full Speed Data +	Analog		VDDUTMII	
DHSDM	USB Device High Speed Data -	Analog		VDDUTMII	
DHSDP	USB Device High Speed Data +	Analog		VDDUTMII	

### 3.1 Design Considerations

In order to facilitate schematic capture when using a SAM3U design, Atmel provides a “Schematics Checklist” Application note. Please visit <http://www.atmel.com/products/AT91/>

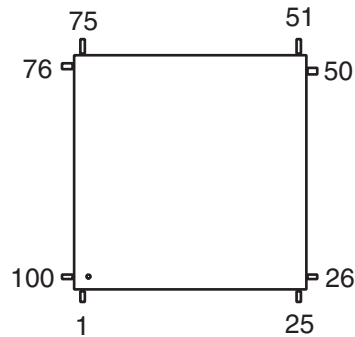
## 4. Package and Pinout

The SAM3U4/2/1E is available in 100-lead LQFP and 100-ball BGA.

The SAM3U4/2/1C is available in 144-lead LQFP and 144-ball LFBGA.

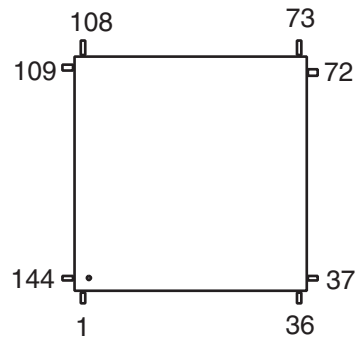
### 4.1 100-lead LQFP Package Outline

Figure 4-1. Orientation of the 100-lead LQFP Package



### 4.2 144-lead LQFP Package Outline

Figure 4-2. Orientation of the 144-lead LQFP Package



### 4.3 100-lead LQFP Pinout

Table 4-1. 100-pin SAM3U Pinout

1	VDDANA	26	PA0/PGMNCMD	51	TDI	76	DHSDP
2	ADVREF	27	PA1/PGMRDY	52	VDDOUT	77	DHSDM
3	GNDANA	28	PA2/PGMNOE	53	VDDIN	78	VBG
4	AD12BVREF	29	PA3/PGMNVALID	54	TDO/TRACESWO	79	VDDUTMI
5	PA22/PGMD12	30	PA4/PGMM0	55	TMS/SWDIO	80	DFSDM
6	PA30	31	PA5/PGMM1	56	TCK/SWCLK	81	DFSDP
7	PB3	32	PA6/PGMM2	57	NRST	82	GNDUTMI
8	PB4	33	PA7/PGMM3	58	PB24	83	VDDCORE
9	VDDCORE	34	VDDCORE	59	VDDCORE	84	PA28
10	PA13/PGMD5	35	GND	60	VDDIO	85	PA29
11	PA14/PGMD6	36	VDDIO	61	GND	86	PA31
12	PA15/PGMD7	37	PA8/PGMD0	62	PB23	87	VDDCORE
13	PA16/PGMD8	38	PA9/PGMD1	63	PB22	88	VDDIO
14	PA17/PGMD9	39	PA10/PGMD2	64	PB21	89	GND
15	PB16	40	PA11/PGMD3	65	PB20	90	PB0
16	PB15	41	PA12/PGMD4	66	PB19	91	PB1
17	PA18/PGMD10	42	FWUP	67	PB18	92	PB2
18	PA19/PGMD11	43	ERASE	68	PB17	93	PB11
19	PA20/PGMD12	44	TEST	69	PB14	94	PB12
20	PA21/PGMD13	45	VDDBU	70	PB10	95	PB13
21	PA23/PGMD15	46	GNDDBU	71	PB9	96	PA27
22	VDDIO	47	NRSTB	72	GNDPLL	97	PB5
23	PA24	48	JTAGSEL	73	VDDPLL	98	PB6
24	PA25	49	XOUT32	74	XOUT	99	PB7
25	PA26	50	XIN32	75	XIN	100	PB8

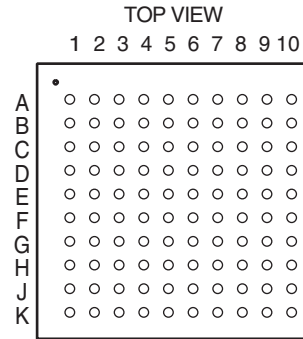
## 4.4 144-lead LQFP Pinout

**Table 4-2.** 144-pin SAM3U Pinout

1	TDI	37	DHSDP	73	VDDANA	109	PA0/PGMNCMD
2	VDDOUT	38	DHSDM	74	ADVREF	110	PC0
3	VDDIN	39	VBG	75	GNDANA	111	PA1/PGMRDY
4	TDO/TRACESWO	40	VDDUTMI	76	AD12BVREF	112	PC1
5	PB31	41	DFSDM	77	PA22/PGMD12	113	PA2/PGMNOE
6	PB30	42	DFSDP	78	PA30	114	PC2
7	TMS/SWDIO	43	GNDUTMI	79	PB3	115	PA3/PGMNVALID
8	PB29	44	VDDCORE	80	PB4	116	PC3
9	TCK/SWCLK	45	PA28	81	PC15	117	PA4/PGMM0
10	PB28	46	PA29	82	PC16	118	PC4
11	NRST	47	PC22	83	PC17	119	PA5/PGMM1
12	PB27	48	PA31	84	PC18	120	PC5
13	PB26	49	PC23	85	VDDIO	121	PA6/PGMM2
14	PB25	50	VDDCORE	86	VDDCORE	122	PC6
15	PB24	51	VDDIO	87	PA13/PGMD5	123	PA7/PGMM3
16	VDDCORE	52	GND	88	PA14/PGMD6	124	PC7
17	VDDIO	53	PB0	89	PC10	125	VDDCORE
18	GND	54	PC24	90	GND	126	GND
19	PB23	55	PB1	91	PA15/PGMD7	127	VDDIO
20	PB22	56	PC25	92	PC11	128	PA8/PGMD0
21	PB21	57	PB2	93	PA16/PGMD8	129	PC8
22	PC21	58	PC26	94	PC12	130	PA9/PGMD1
23	PB20	59	PB11	95	PA17/PGMD9	131	PC9
24	PB19	60	GND	96	PB16	132	PA10/PGMD2
25	PB18	61	PB12	97	PB15	133	PA11/PGMD3
26	PB17	62	PB13	98	PC13	134	PA12/PGMD4
27	VDDCORE	63	PC27	99	PA18/PGMD10	135	FWUP
28	PC14	64	PA27	100	PA19/PGMD11	136	SHDN
29	PB14	65	PB5	101	PA20/PGMD12	137	ERASE
30	PB10	66	PB6	102	PA21/PGMD13	138	TEST
31	PB9	67	PB7	103	PA23/PGMD15	139	VDDBU
32	PC19	68	PB8	104	VDDIO	140	GNDBU
33	GNDPLL	69	PC28	105	PA24	141	NRSTB
34	VDDPLL	70	PC29	106	PA25	142	JTAGSEL
35	XOUT	71	PC30	107	PA26	143	XOUT32
36	XIN	72	PC31	108	PC20	144	XIN32

## 4.5 100-ball LFBGA Package Outline

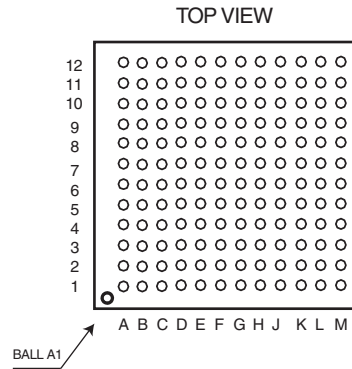
**Figure 4-3.** Orientation of the 100-ball LFBGA Package



## 4.6 144-ball LFBGA Package Outline

The 144-Ball LFBGA package has a 0.8 mm ball pitch and respects Green Standards. Its dimensions are 10 x 10 x 1.4 mm.

**Figure 4-4.** Orientation of the 144-ball LFBGA Package



## 4.7 100-ball LFBGA Pinout

To be supplied.

## 4.8 144-ball LFBGA Pinout

To be supplied.

## 5. Power Considerations

### 5.1 Power Supplies

The SAM3U product has several types of power supply pins:

- VDDCORE pins: Power the core, the embedded memories and the peripherals; voltage ranges from 1.62V and 1.95V.
- VDDIO pins: Power the Peripherals I/O lines; voltage ranges from 1.62V and 3.6V.
- VDDIN pin: Powers the Voltage regulator
- VDDOUT pin: It is the output of the voltage regulator.
- VDDBU pin: Powers the Slow Clock oscillator and a part of the System Controller; voltage ranges from 1.62V and 3.6V. VDDBU must be supplied before or at the same time than VDDIO and VDDCORE.
- VDDPLL pin: Powers the PLL A, UPLL and 3-20 MHz Oscillator; voltage ranges from 1.62V and 1.95V.
- VDDUTMI pin: Powers the UTMI+ interface; voltage ranges from 3.0V and 3.6V, 3.3V nominal.
- VDDANA pin: Powers the ADC cells; voltage ranges from 2.4V and 3.6V.

Ground pins GND are common to VDDCORE and VDDIO pins power supplies.

Separated ground pins are provided for VDDBU, VDDPLL, VDDUTMI and VDDANA. These ground pins are respectively GNDBU, GNDPLL, GNDUTMI and GNDANA.

### 5.2 Voltage Regulator

The SAM3U embeds a voltage regulator that is managed by the Supply Controller.

This internal regulator is intended to supply the internal core of SAM3U but can be used to supply other parts in the application. It features two different operating modes:

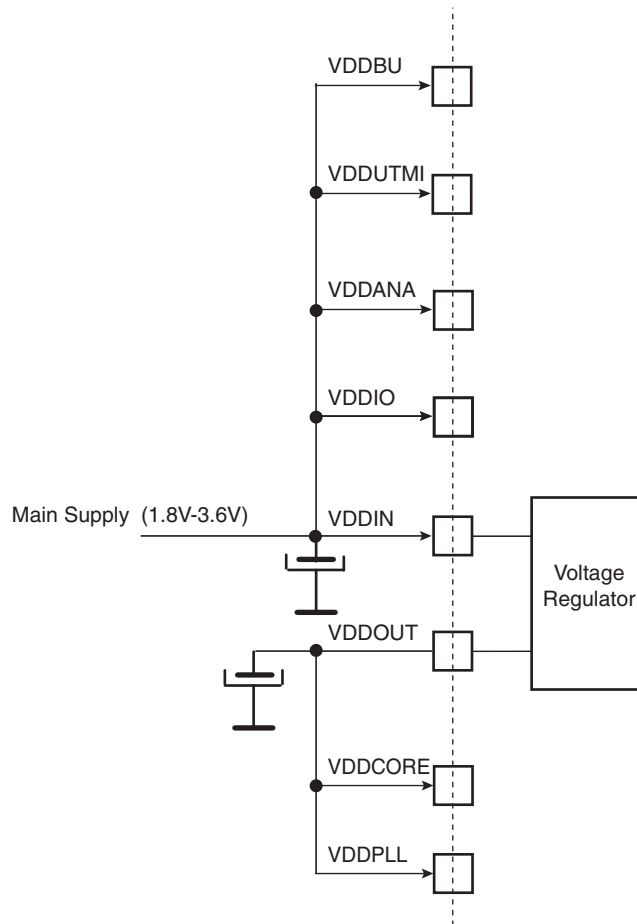
- In Normal mode, the voltage regulator consumes less than 700  $\mu$ A static current and draws 150 mA of output current. Internal adaptive biasing adjusts the regulator quiescent current depending on the required load current. In Wait Mode or when the output current is low, quiescent current is only 7 $\mu$ A.
- In Shutdown mode, the voltage regulator consumes less than 1  $\mu$ A while its output is driven internally to GND. The default output voltage is 1.80V and the start-up time to reach Normal mode is inferior to 400  $\mu$ s.

For adequate input and output power supply decoupling/bypassing, refer to the Voltage Regulator section in the Electrical Characteristics section of the datasheet.

### 5.3 Typical Powering Schematics

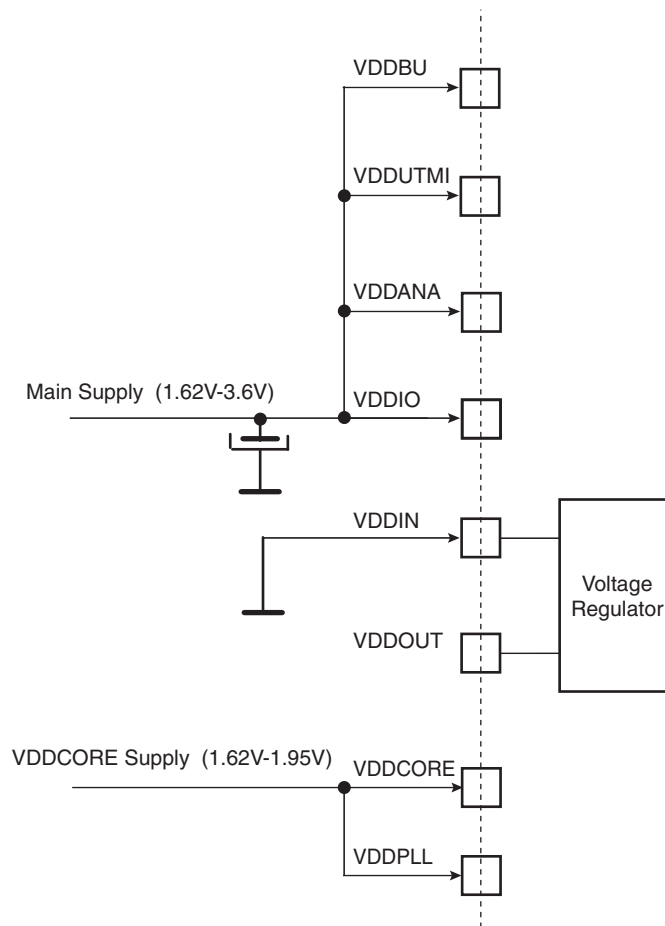
The SAM3U supports a 1.62V-3.6V single supply mode. The internal regulator input connected to the source and its output feeds VDDCORE. [Figure 5-6](#) shows the power schematics.

**Figure 5-1.** Single Supply



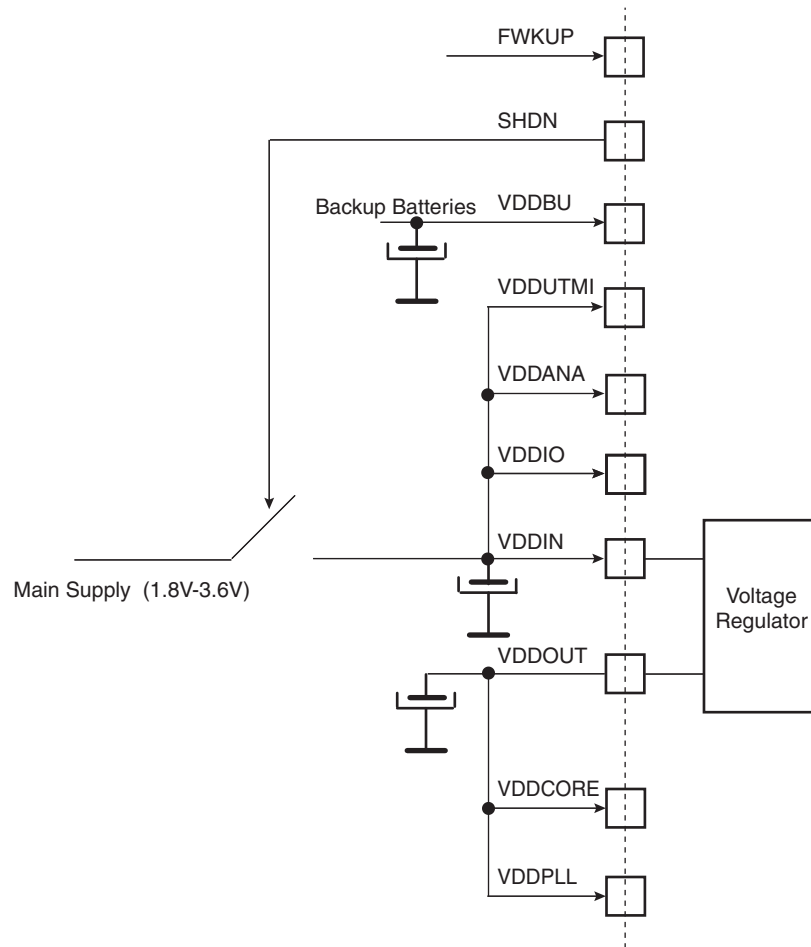
Note: Restrictions  
 With Main Supply < 2.4 V, USB and ADC are not usable.  
 With Main Supply  $\geq$  2.4V and < 3V, USB is not usable.  
 With Main Supply  $\geq$  3V, all peripherals are usable.

**Figure 5-2. Core Externally Supplied**



**Note: Restrictions**  
 With Main Supply < 2.4 V, USB and ADC are not usable.  
 With Main Supply  $\geq$  2.4V and < 3V, USB is not usable.  
 With Main Supply  $\geq$  3V, all peripherals are usable.

**Figure 5-3.** Backup Batteries Used



Note: Restrictions  
 With Main Supply < 2.4 V, USB and ADC are not usable.  
 With Main Supply  $\geq$  2.4V and < 3V, USB is not usable.  
 With Main Supply  $\geq$  3V, all peripherals are usable.

## 5.4 Active Mode

Active mode is the normal running mode with the core clock running from the fast RC oscillator, the main crystal oscillator or the PLLA. The power management controller can be used to adapt the frequency and to disable the peripheral clocks.

## 5.5 Low Power Modes

The various low power modes of the SAM3U are described below:

### 5.5.1 Backup Mode

The purpose of backup mode is to achieve the lowest power consumption possible in a system which is performing periodic wake-ups to perform tasks but not requiring fast startup time (<0.5ms).

The Supply Controller, zero-power power-on reset, RTT, RTC, Backup registers and 32 kHz Oscillator (RC or crystal oscillator selected by software in the Supply Controller) are running. The regulator and the core supply are off.

Backup Mode is based on the Cortex-M3 deep-sleep mode with the voltage regulator disabled.

The SAM3U Series can be awakened from this mode through the Force Wake-Up pin (FWUP), and Wake-Up input pins WUP0 to WUP15, BOD, RTT or RTC wake-up event. Current Consumption is 2.5  $\mu$ A typical on VDDBU.

Backup mode is entered by using WFE instructions with the SLEEPDEEP bit in the System Control Register of the Cortex-M3 set to 1. (See the Power management description in The ARM Cortex M3 Processor section of the product datasheet).

Exit from Backup mode happens if one of the following enable wake up events occurs:

- FWUP pin (low level, configurable debouncing)
- WKUPEN0-15 pins (level transition, configurable debouncing)
- BOD alarm
- RTC alarm
- RTT alarm

### 5.5.2 Wait Mode

The purpose of the wait mode is to achieve very low power consumption while maintaining the whole device in a powered state for a startup time of less than 10  $\mu$ s.

In this mode, the clocks of the core, peripherals and memories are stopped. However, the core, peripherals and memories power supplies are still powered. From this mode, a fast start up is available.

This mode is entered via Wait for Event (WFE) instructions with LPM = 1 (Low Power Mode bit in PMC\_FSMR). The Cortex-M3 is able to handle external events or internal events in order to wake-up the core (WFE). By configuring the external lines WUP0-15 as fast startup wake-up pins (refer to [Section 5.7 “Fast Start-Up”](#)). RTC or RTT Alarm and USB wake-up events can be used to wake up the CPU (exit from WFE).

Current Consumption in Wait mode is typically 15  $\mu$ A on VDDIN if the internal voltage regulator is used or 8  $\mu$ A on VDDCORE if an external regulator is used.

Entering Wait Mode:

- Select the 4/8/12 MHz Fast RC Oscillator as Main Clock
- Set the LPM bit in the PMC Fast Startup Mode Register (PMC\_FSMR)
- Execute the Wait-For-Event (WFE) instruction of the processor

Note: Internal Main clock resynchronization cycles are necessary between the writing of MOSCRREN bit and the effective entry in Wait mode. Depending on the user application, Waiting for MOSCRREN bit to be cleared is recommended to ensure that the core will not execute undesired instructions.

### 5.5.3 Sleep Mode

The purpose of sleep mode is to optimize power consumption of the device versus response time. In this mode, only the core clock is stopped. The peripheral clocks can be enabled. This mode is entered via Wait for Interrupt (WFI) or Wait for Event (WFE) instructions with LPM = 0 in PMC\_FSMR.

The processor can be woke up from an interrupt if WFI instruction of the Cortex M3 is used, or from an event if the WFE instruction is used to enter this mode.

## 5.5.4 Low Power Mode Summary Table

The modes detailed above are the main low power modes. Each part can be set to on or off separately and wake up sources can be individually configured. [Table 5-1](#) below shows a summary of the configurations of the low power modes.

**Table 5-1.** Low Power Mode Configuration Summary

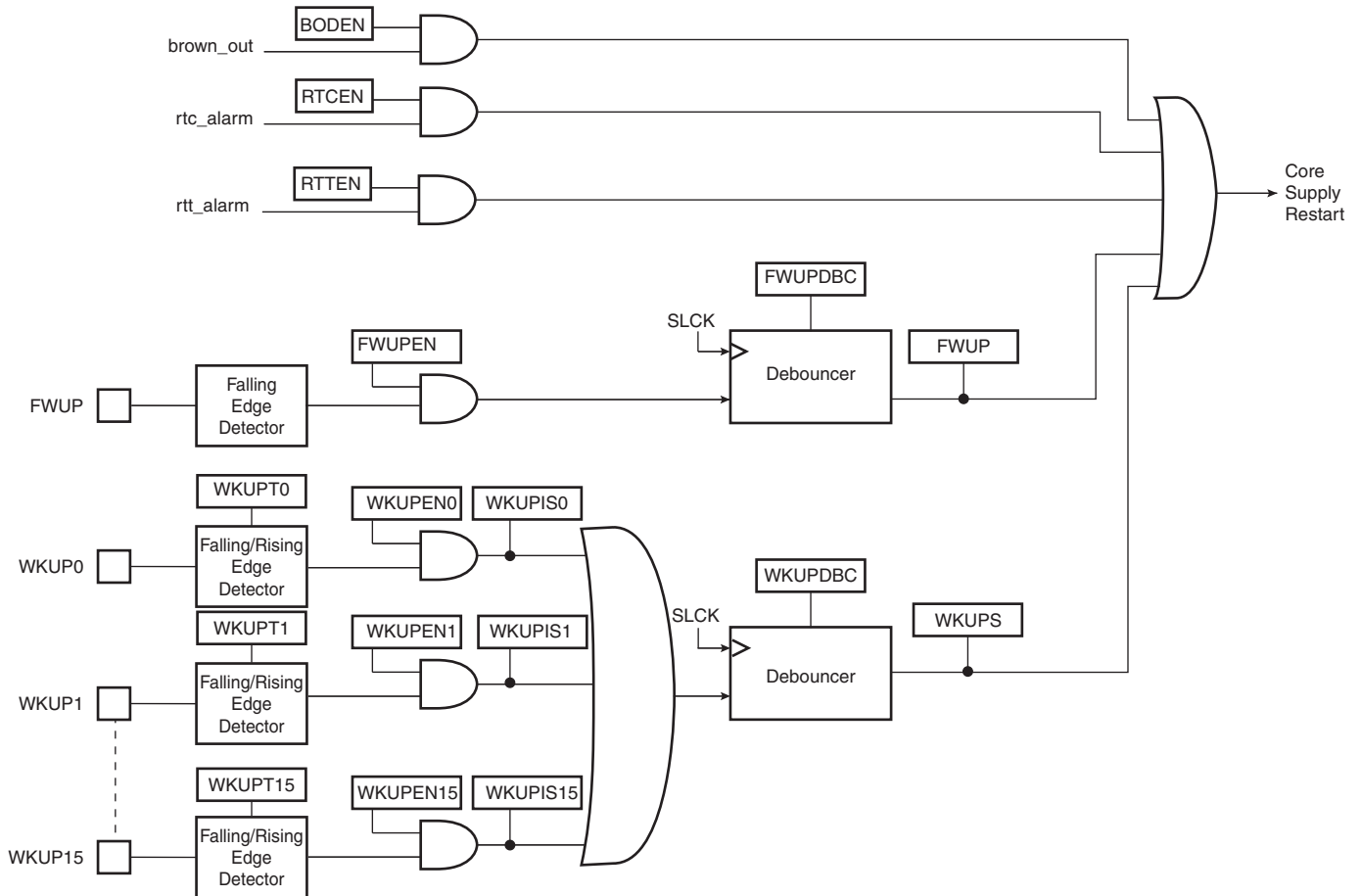
Mode	SUPC, 32 kHz Oscillator RTC RTT Backup Registers, POR (VDDBU Region)	Regulator	Core Memory Peripherals	Mode Entry	Potential Wake Up Sources	Core at Wake Up	PIO State while in Low Power Mode	PIO State at Wake Up	Consumption <sup>(2) (3)</sup>	Wake-up Time <sup>(1)</sup>
Backup Mode	ON	OFF SHDN =0	OFF (Not powered)	WFE +SLEEPDEEP bit = 1	FWUP pin WUP0-15 pins BOD alarm RTC alarm RTT alarm	Reset	PIOA & PIOB Inputs with pull-ups	PIOA & PIOB & PIOC Inputs with pull ups	2.5 $\mu$ A typ <sup>(4)</sup>	< 0.5 ms
Wait Mode	ON	ON SHDN =1	Powered (Not clocked)	WFE +SLEEPDEEP bit = 0 +LPM bit = 1	Any Event from: Fast startup through WUP0-15 pins RTC alarm RTT alarm USB wake-up	Clocked back	Previous state saved	Unchanged	8 $\mu$ A/15 $\mu$ A <sup>(5)</sup>	< 10 $\mu$ s
Sleep Mode	ON	ON SHDN =1	Powered <sup>(7)</sup> (Not clocked)	WFE or WFI +SLEEPDEEP bit = 0 +LPM bit = 0	Entry mode =WFI Interrupt Only; Entry mode =WFE Any Enabled Interrupt and/or Any Event from: Fast start-up through WUP0-15 pins RTC alarm RTT alarm USB wake-up	Clocked back	Previous state saved	Unchanged <sup>(6)</sup>	<sup>(6)</sup>	<sup>(6)</sup>

- Notes:
1. When considering wake-up time, the time required to start the PLL is not taken into account. Once started, the device works with the 4/8/12 MHz Fast RC oscillator. The user has to add the PLL start-up time if it is needed in the system. The wake-up time is defined as the time taken for wake up until the first instruction is fetched.
  2. The external loads on PIOs are not taken into account in the calculation.
  3. BOD current consumption is not included.
  4. Current consumption on VDDBU.
  5. 8  $\mu$ A or VDDCORE, 15  $\mu$ A on VDDIN.
  6. Depends on MCK frequency.
  7. In this mode the core is supplied and not clocked but some peripherals can be clocked.

## 5.6 Wake-up Sources

The wake-up events allow the device to exit backup mode. When a wake-up event is detected, the Supply Controller performs a sequence which automatically reenables the core power supply.

**Figure 5-4.** Wake-up Source

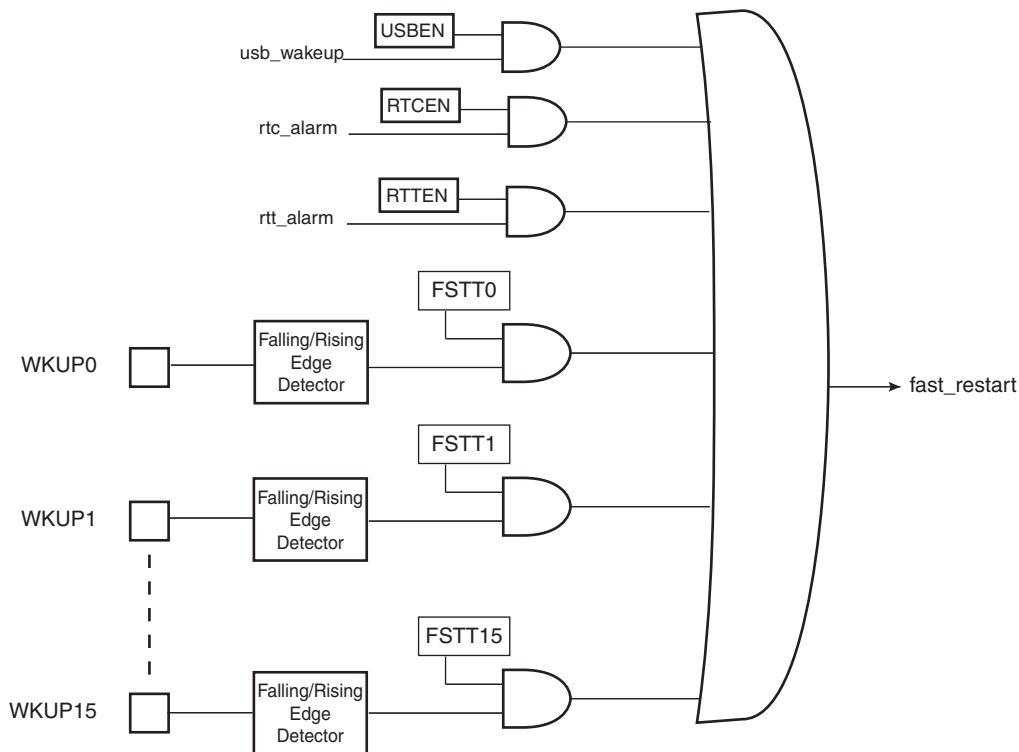


## 5.7 Fast Start-Up

The SAM3U allows the processor to restart in a few microseconds while the processor is in wait mode. A fast start up can occur upon detection of a low level on one of the 19 wake-up inputs.

The fast restart circuitry, as shown in Figure 5-5, is fully asynchronous and provides a fast start-up signal to the Power Management Controller. As soon as the fast start-up signal is asserted, the PMC automatically restarts the embedded 4/8/12 MHz fast RC oscillator, switches the master clock on this 4/8/12 MHz clock and reenables the processor clock.

Figure 5-5. Fast Start-Up Sources



## 5.8 Programmable I/O Lines Power Supplies

All the I/O lines integrate a programmable pull-up resistor. Programming of this pull-up resistor is performed independently for each I/O line through the PIO controllers. All I/Os have input schmitt triggers.

The PIO lines are supplied through VDDIO and the speed of the signal that can be driven on them can reach 35 MHz on 25 pF at 1.62V and 45 MHz at 3.0V.

The HSMCI and SPI clock lines use specific I/Os: they can reach 45 MHz on 30pF at 1.62V and 55 MHz at 3.0V.

Typical pull-up value is 100 kΩ for all I/Os.

Each I/O embeds an ODT (On-Die Termination). It consists to an internal serial resistor which avoids the reflection on the board and so reduce the number of components.

## 6. I/O Line Considerations

### 6.1 JTAG Port Pins

TDI and TCK/SWCLK are schmitt trigger inputs and have no pull-up resistors.

TMS/SWDIO is an input/output with schmitt trigger with no pull-up resistor.

TDO/TRACESWO is an output.

The JTAGSEL pin is used to select the JTAG boundary scan when asserted at a high level. It integrates a permanent pull-down resistor of about 15 k $\Omega$  to GNDBU, so that it can be left unconnected for normal operations.

By default, the JTAG Debug Port is active. If the debugger host wants to switch to the Serial Wire Debug Port, it must provide a dedicated JTAG sequence on TMS/SWDIO and TCK/SWCLK which disables the JTAG-DP and enables the SW-DP. When the Serial Wire Debug Port is active, TDO/TRACESWO can be used for trace.

The asynchronous TRACE output (TRACESWO) is multiplexed with TDO. So the asynchronous trace can only be used with SW-DP, not JTAG-DP.

All the JTAG signals are supplied with VDDIO except JTAGSEL, supplied by VDDBU.

### 6.2 Test Pin

The TST pin is used for JTAG Boundary Scan Manufacturing Test or fast flash programming mode of the SAM3U series. The TST pin integrates a permanent pull-down resistor of about 15 k $\Omega$  to GND, so that it can be left unconnected for normal operations. To enter fast programming mode, see the Fast Flash Programming Interface (FFPI) section. For more on the manufacturing and test mode, refer to the “Debug and Test” section of the product datasheet.

### 6.3 NRST Pin

The NRST pin is bidirectional. It is handled by the on-chip reset controller and can be driven low to provide a reset signal to the external components or asserted low externally to reset the microcontroller. It will reset the Core and the peripherals except the Backup region (RTC, RTT and Supply Controller). There is no constraint on the length of the reset pulse and the reset controller can guarantee a minimum pulse length.

The NRST pin integrates a permanent pull-up resistor to VDDIO of about 100 k $\Omega$ .

### 6.4 NRSTB Pin

The NRSTB pin is input only and enables asynchronous reset of the SAM3U when asserted low. The NRSTB pin integrates a permanent pull-up resistor of about 15 k $\Omega$ . This allows connection of a simple push button on the NRSTB pin as a system-user reset. In all modes, this pin will reset the chip including the Backup region (RTC, RTT and Supply Controller). It reacts as the Power-on reset. It can be used as an external system reset source. In harsh environments, it is recommended to add an external capacitor (10 nF) between NRSTB and VDDIO.

It embeds an anti-glitch filter.

## 6.5 ERASE Pin

The ERASE pin is used to reinitialize the Flash content and some of its NVM bits. It integrates a permanent pull-down resistor of about 15 k $\Omega$  to GND, so that it can be left unconnected for normal operations.

This pin is debounced by SCLK to improve the glitch tolerance. When the ERASE pin is tied high during less than 100 ms, it is not taken into account. The pin must be tied high during more than 220 ms to perform the reinitialization of the Flash.

Even in all low power modes, asserting the pin will automatically start-up the chip and erase the Flash.

## 6.6 PIO Controllers

All the I/O lines managed by the PIO Controllers integrate a programmable pull-up resistor of 100 k $\Omega$  typical. Programming of this pull-up resistor is performed independently for each I/O line through the PIO Controllers.

After reset, all the I/O lines default as inputs with pull-up resistors enabled.

## 7. Processor and Architecture

### 7.1 ARM Cortex-M3 Processor

- Version 2.0
- Thumb-2 (ISA) subset consisting of all base Thumb-2 instructions, 16-bit and 32-bit.
- Harvard processor architecture enabling simultaneous instruction fetch with data load/store.
- Three-stage pipeline.
- Single cycle 32-bit multiply.
- Hardware divide.
- Thumb and Debug states.
- Handler and Thread modes.
- Low latency ISR entry and exit.

### 7.2 APB/AHB Bridges

The SAM3U product embeds two separated APB/AHB bridges:

- low speed bridge
- high speed bridge

This architecture enables to make concurrent accesses on both bridges.

All the peripherals are on the low-speed bridge except SPI, SSC and HSMCI.

The UART, ADC0-1, TWI0-1, USART0-3, PWM have dedicated channels for the Peripheral DMA Channels (PDC). These peripherals can not use the DMA Controller.

The high speed bridge regroups the SSC, SPI and HSMCI. These three peripherals do not have PDC channels but can use the DMA with the internal FIFO for Channel buffering.

Note that the peripherals of the two bridges are clocked by the same source: MCK.

### 7.3 Matrix Masters

The Bus Matrix of the SAM3U device manages 5 masters, which means that each master can perform an access concurrently with others to an available slave.

Each master has its own decoder and specifically defined bus. In order to simplify the addressing, all the masters have the same decoding.

**Table 7-1.** List of Bus Matrix Masters

Master 0	Cortex-M3 Instruction/Data
Master 1	Cortex-M3 System
Master 2	Peripheral DMA Controller (PDC)
Master 3	USB Device High Speed DMA
Master 4	DMA Controller

## 7.4 Matrix Slaves

The Bus Matrix of the SAM3U manages 10 slaves. Each slave has its own arbiter, allowing a different arbitration per slave.

**Table 7-2.** List of Bus Matrix Slaves

Slave 0	Internal SRAM0
Slave 1	Internal SRAM1
Slave 2	Internal ROM
Slave 3	Internal Flash 0
Slave 4	Internal Flash 1
Slave 5	USB Device High Speed Dual Port RAM (DPR)
Slave 6	NAND Flash Controller RAM
Slave 7	External Bus Interface
Slave 8	Low Speed Peripheral Bridge
Slave 9	High Speed Peripheral Bridge

## 7.5 Master to Slave Access

All the Masters can normally access all the Slaves. However, some paths do not make sense, for example allowing access from the USB Device High speed DMA to the Internal Peripherals. Thus, these paths are forbidden or simply not wired, and shown as “–” in [Table 7-3](#) below.

**Table 7-3.** SAM3U Master to Slave Access

Slaves	Masters	0	1	2	3	4
		Cortex-M3 I/D Bus	Cortex-M3 S Bus	PDC	USB Device High Speed DMA	DMA Controller
0	Internal SRAM0	–	X	X	X	X
1	Internal SRAM1	–	X	X	X	X
2	Internal ROM	X	–	X	X	X
3	Internal Flash 0	X	–	–	–	–
4	Internal Flash 1	X	–	–	–	–
5	USB Device High Speed Dual Port RAM (DPR)	–	X	–	–	–
6	NAND Flash Controller RAM	–	X	X	X	X
7	External Bus Interface	–	X	X	X	X
8	Low Speed Peripheral Bridge	–	X	X	–	–

## 7.6 DMA Controller

- Acting as one Matrix Master
- Embeds 4 channels:
  - 3 channels with 8 bytes/FIFO for Channel Buffering
  - 1 channel with 32 bytes/FIFO for Channel Buffering
- Linked List support with Status Write Back operation at End of Transfer
- Word, HalfWord, Byte transfer support.
- Handles high speed transfer of SPI, SSC and HSMCI (peripheral to memory, memory to peripheral)
- Memory to memory transfer
- Can be triggered by PWM and T/C which enables to generate waveforms though the External Bus Interface

The DMA controller can handle the transfer between peripherals and memory and so receives the triggers from the peripherals listed below. The hardware interface numbers are also given in [Table 7-4](#) below.

**Table 7-4.** DMA Controller

Instance name	Channel T/R	DMA Channel HW interface Number
HSMCI	Transmit/Receive	0
SPI	Transmit	1
SPI	Receive	2
SSC	Transmit	3
SSC	Receive	4
PWM Event Line 0	Trigger	5
PWM Event Line 1	Trigger	6
TIO Output of Timer Counter Channel 0	Trigger	7

## 7.7 Peripheral DMA Controller

- Handles data transfer between peripherals and memories
- Nineteen channels
  - Two for each USART
  - Two for the UART
  - Two for each Two Wire Interface
  - One for the PWM
  - One for each Analog-to-digital Converter
- Low bus arbitration overhead
  - One Master Clock cycle needed for a transfer from memory to peripheral
  - Two Master Clock cycles needed for a transfer from peripheral to memory
- Next Pointer management for reducing interrupt latency requirement

The Peripheral DMA Controller handles transfer requests from the channel according to the following priorities (Low to High priorities):

**Table 7-5.** Peripheral DMA Controller

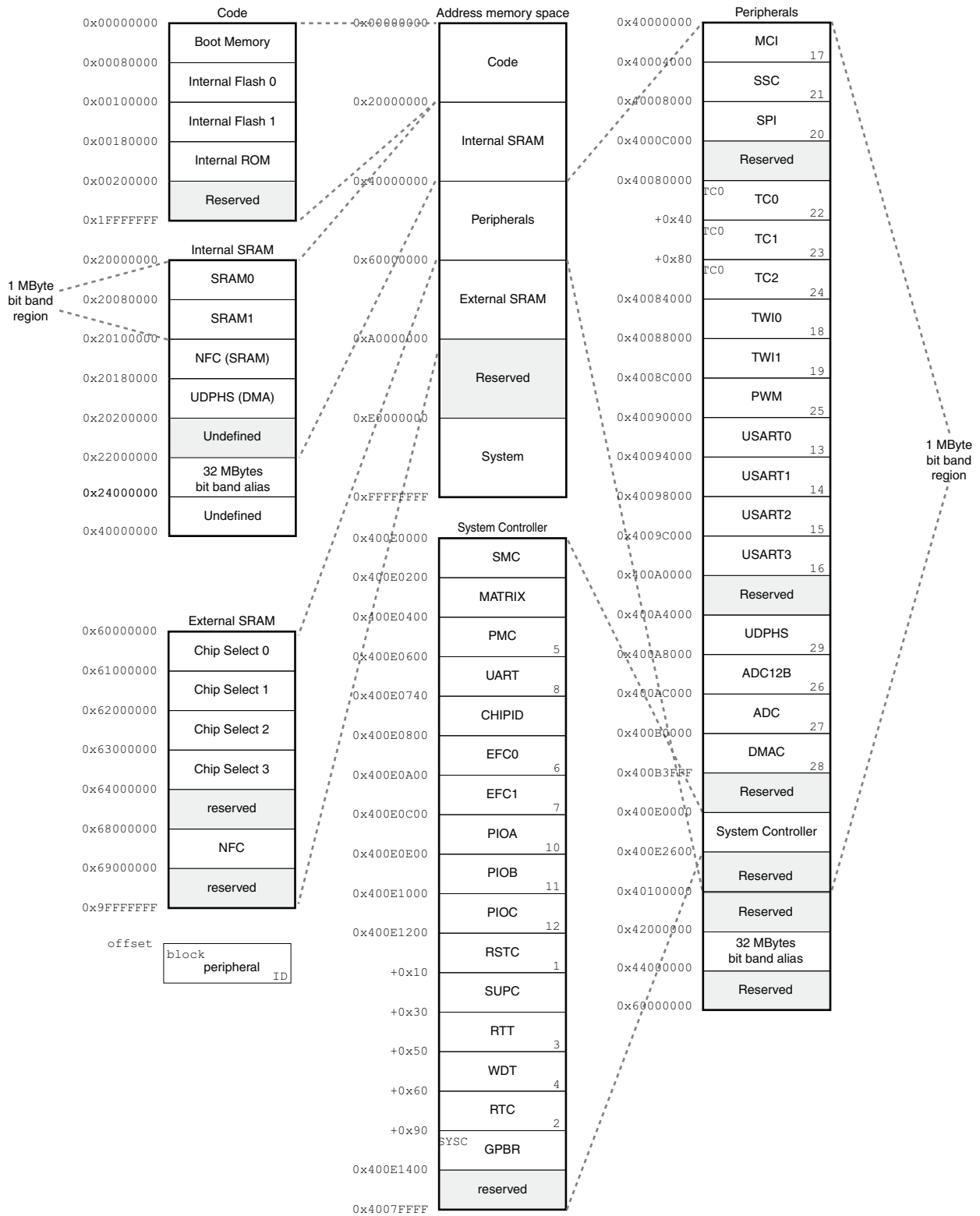
Instance name	Channel T/R
TWI1	Transmit
TWI0	Transmit
PWM	Transmit
UART	Transmit
USART3	Transmit
USART2	Transmit
USART1	Transmit
USART0	Transmit
TWI0	Receive
TWI1	Receive
UART	Receive
USART3	Receive
USART2	Receive
USART1	Receive
USART0	Receive
ADC	Receive
ADC12B	Receive

## 7.8 Debug and Test Features

- Debug access to all memory and registers in the system, including Cortex-M3 register bank when the core is running, halted, or held in reset.
- Serial Wire Debug Port (SW-DP) and Serial Wire JTAG Debug Port (SWJ-DP) debug access
- Flash Patch and Breakpoint (FPB) unit for implementing break points and code patches
- Data Watchpoint and Trace (DWT) unit for implementing watch points, data tracing, and system profiling
- Instrumentation Trace Macrocell (ITM) for support of printf style debugging
- IEEE® 1149.1 JTAG Boundary-scan on all digital pins

## 8. Memories

Figure 8-1. SAM3U Memory Mapping



## 8.1 Embedded Memories

### 8.1.1 Internal SRAM

The SAM3U4 (256-KBytes internal Flash version) embeds a total of 48-Kbytes high-speed SRAM (32-Kbytes SRAM0 and 16-Kbytes SRAM1).

The SAM3U2 (128-KBytes internal Flash version) embeds a total of 32-Kbytes high-speed SRAM (16-Kbytes SRAM0 and 16-Kbytes SRAM1).

The SAM3U1 (64-KBytes internal Flash version) embeds a total of 16-Kbytes high-speed SRAM (8-Kbytes SRAM0 and 8-Kbytes SRAM1).

The SRAM0 is accessible over System Cortex-M3 bus at address 0x2000 0000 and SRAM1 at address 0x2008 0000. The user can see the SRAM as contiguous.

The SRAM0 and SRAM1 are in the bit band region. The bit band alias region is from 0x2200 0000 and 0x23FF FFFF.

The NAND Flash Controller embeds 4224 bytes of internal SRAM. If the NAND Flash controller is not used, these 4224 Kbytes of SRAM can be used as general purpose. It can be seen at address 0x2010 0000.

### 8.1.2 Internal ROM

The SAM3U product embeds an Internal ROM, which contains the SAM-BA Boot and FFPI program.

At any time, the ROM is mapped at address 0x0018 0000.

### 8.1.3 Embedded Flash

#### 8.1.3.1 Flash Overview

The Flash of the SAM3U4 (256-KBytes internal Flash version) is organized in two banks of 512 pages (dual plane) of 256 bytes.

The Flash of the SAM3U2 (128-KBytes internal Flash version) is organized in one bank of 512 pages (single plane) of 256 bytes.

The Flash of the SAM3U1 (256-KBytes internal Flash version) is organized in one bank of 256 pages (single plane) of 256 bytes.

The Flash contains a 128-byte write buffer, accessible through a 32-bit interface.

#### 8.1.3.2 Flash Power Supply

The Flash is supplied by VDDCORE.

#### 8.1.3.3 Enhanced Embedded Flash Controller

The Enhanced Embedded Flash Controller (EEFC) manages accesses performed by the masters of the system. It enables reading the Flash and writing the write buffer. It also contains a User Interface, mapped within the Memory Controller on the APB.

The Enhanced Embedded Flash Controller ensures the interface of the Flash block with the 32-bit internal bus. Its 128-bit wide memory interface increases performance.

The user can choose between high performance or lower current consumption by selecting either 128-bit or 64-bit access. It also manages the programming, erasing, locking and unlocking sequences of the Flash using a full set of commands.

One of the commands returns the embedded Flash descriptor definition that informs the system about the Flash organization, thus making the software generic.

The SAM3U4 (256-KBytes internal Flash version) embeds two EEFC (EEFC0 for Flash0 and EEFC1 for Flash1) whereas the SAM3U2/1 embeds one EEFC.

#### 8.1.3.4 Lock Regions

In the **SAM3U4** (256 KBytes internal Flash version) two Enhanced Embedded Flash Controllers each manage 16 lock bits to protect 32 regions of the flash against inadvertent flash erasing or programming commands.

The **SAM3U4** (256 KBytes internal Flash version) contains 32 lock regions and each lock region contains 32 pages of 256 bytes. Each lock region has a size of 8 Kbytes.

The **SAM3U2** (128 KBytes internal Flash version) Enhanced Embedded Flash Controller manages 16 lock bits to protect 32 regions of the flash against inadvertent flash erasing or programming commands.

The **SAM3U2** (128 KBytes internal Flash version) contains 16 lock regions and each lock region contains 32 pages of 256 bytes. Each lock region has a size of 8 Kbytes.

The **SAM3U1** (64 KBytes internal Flash version) Embedded Flash Controller manages 8 lock bits to protect 8 regions of the flash against inadvertent flash erasing or programming commands.

The **SAM3U1** (64-KBytes internal Flash version) contains 8 lock regions and each lock region contains 32 pages of 256 bytes. Each lock region has a size of 8 Kbytes.

If a locked-region's erase or program command occurs, the command is aborted and the EEFC triggers an interrupt.

The lock bits are software programmable through the EEFC User Interface. The command "Set Lock Bit" enables the protection. The command "Clear Lock Bit" unlocks the lock region.

Asserting the ERASE pin clears the lock bits, thus unlocking the entire Flash.

#### 8.1.3.5 Security Bit Feature

The SAM3U features a security bit, based on a specific General Purpose NVM bit (GPNVM bit 0). When the security is enabled, any access to the Flash, either through the ICE interface or through the Fast Flash Programming Interface, is forbidden. This ensures the confidentiality of the code programmed in the Flash.

This security bit can only be enabled, through the command "Set General Purpose NVM Bit 0" of the EEFC User Interface. Disabling the security bit can only be achieved by asserting the ERASE pin at 1, and after a full Flash erase is performed. When the security bit is deactivated, all accesses to the Flash are permitted.

It is important to note that the assertion of the ERASE pin should always be longer than 200 ms. As the ERASE pin integrates a permanent pull-down, it can be left unconnected during normal operation. However, it is safer to connect it directly to GND for the final application.

#### 8.1.3.6 Calibration Bits

NVM bits are used to calibrate the brownout detector and the voltage regulator. These bits are factory configured and cannot be changed by the user. The ERASE pin has no effect on the calibration bits.

### 8.1.3.7 Unique Identifier

Each device integrates its own 128-bit unique identifier. These bits are factory configured and cannot be changed by the user. The ERASE pin has no effect on the unique identifier.

### 8.1.3.8 Fast Flash Programming Interface

The Fast Flash Programming Interface allows programming the device through either a serial JTAG interface or through a multiplexed fully-handshaked parallel port. It allows gang programming with market-standard industrial programmers.

The FFPI supports read, page program, page erase, full erase, lock, unlock and protect commands.

The Fast Flash Programming Interface is enabled and the Fast Programming Mode is entered when TST, NRSTB and FWUP pins are tied high during power up sequence and if all supplies are provided externally (do not use internal regulator for VDDCORE). Please note that since the FFPI is a part of the SAM-BA Boot Application, the device must boot from the ROM.

### 8.1.3.9 SAM-BA<sup>®</sup> Boot

The SAM-BA Boot is a default Boot Program which provides an easy way to program in-situ the on-chip Flash memory.

The SAM-BA Boot Assistant supports serial communication via the UART and USB.

The SAM-BA Boot provides an interface with SAM-BA Graphic User Interface (GUI).

The SAM-BA Boot is in ROM and is mapped in Flash at address 0x0 when GPNVM bit 1 is set to 0.

### 8.1.3.10 GPNVM Bits

The SAM3U features three GPNVM bits that can be cleared or set respectively through the commands “Clear GPNVM Bit” and “Set GPNVM Bit” of the EEFC User Interface.

The SAM3U4 is equipped with two EEFC, EEFC0 and EEFC1. EEFC1 does not feature the GPNVM bits. The GPNVM embedded on EEFC0 applies to the two blocks in the SAM3U4.

**Table 8-1.** General-purpose Non-volatile Memory Bits

GPNVMBit[#]	Function
0	Security bit
1	Boot mode selection
2	Flash selection (Flash 0 or Flash 1) Only on SAM3U4 (256 Kbytes internal Flash version)

## 8.1.4 Boot Strategies

The system always boots at address 0x0. To ensure a maximum boot possibilities the memory layout can be changed via GPNVM.

A general purpose NVM (GPNVM1) bit is used to boot either on the ROM (default) or from the Flash.

The GPNVM bit can be cleared or set respectively through the commands “Clear General-purpose NVM Bit” and “Set General-purpose NVM Bit” of the EEFC User Interface.

Setting the GPNVM Bit 1 selects the boot from the Flash, clearing it selects the boot from the ROM. Asserting ERASE clears the GPNVM Bit 1 and thus selects the boot from the ROM by default.

GPNVM2 enables to select if Flash 0 or Flash 1 is used for the boot. Setting the GPNVM2 bit selects the boot from Flash 1, clearing it selects the boot from Flash 0.

## 8.2 External Memories

The SAM3U offers an interface to a wide range of external memories and to any parallel peripheral.

### 8.2.1 Static Memory Controller

- 8- or 16- bit Data Bus
- Up to 24-bit Address Bus (up to 16 MBytes linear per chip select)
- Up to 4 chips selects, Configurable Assignment
- Multiple Access Modes supported
  - Byte Write or Byte Select Lines
- Multiple device adaptability
  - Control signals programmable setup, pulse and hold time for each Memory Bank
- Multiple Wait State Management
  - Programmable Wait State Generation
  - External Wait Request
  - Programmable Data Float Time
- Slow Clock mode supported

### 8.2.2 NAND Flash Controller

- Handles automatic Read/Write transfer through 4224 bytes SRAM buffer
- DMA support
- Supports SLC NAND Flash technology
- Programmable timing on a per chip select basis
- Programmable Flash Data width 8-bit or 16-bit

### 8.2.3 NAND Flash Error Corrected Code Controller

- Integrated in the NAND Flash Controller
- Single bit error correction and 2-bit Random detection.
- Automatic Hamming Code Calculation while writing
  - ECC value available in a register
- Automatic Hamming Code Calculation while reading
  - Error Report, including error flag, correctable error flag and word address being detected erroneous
  - Supports 8- or 16-bit NAND Flash devices with 512-, 1024-, 2048- or 4096-byte pages

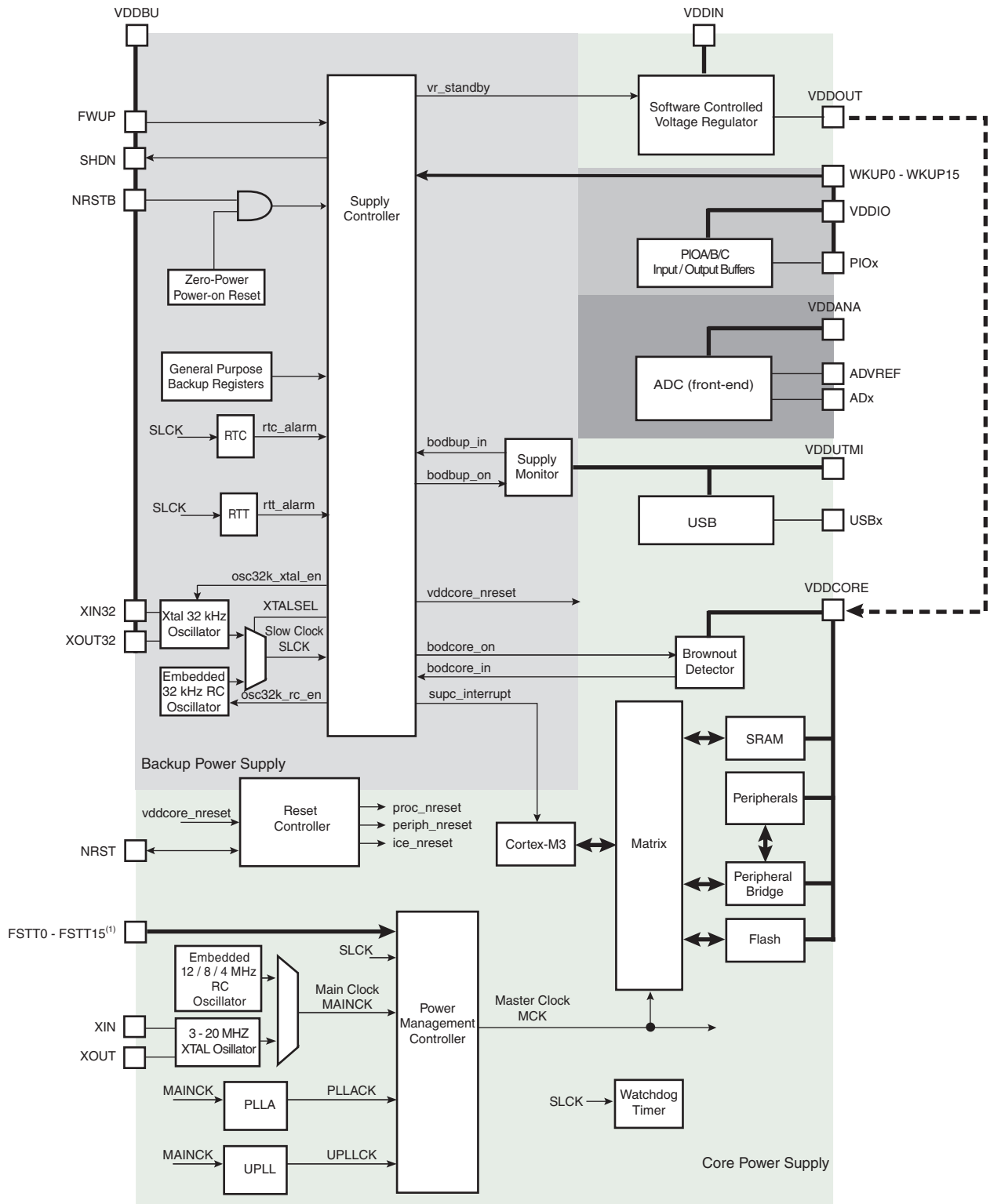
## 9. System Controller

The System Controller is a set of peripherals, which allow handling of key elements of the system, such as power, resets, clocks, time, interrupts, watchdog, etc...

The System Controller User Interface also embeds the registers used to configure the Matrix.

See the system controller block diagram in [Figure 9-1 on page 34](#).

**Figure 9-1. System Controller Block Diagram**



<sup>(1)</sup>FSTT0 - FSTT15 are possible Fast Startup Sources, generated by WKUP0-WKUP15 pins but are not physical pins.

## 9.1 System Controller and Peripheral Mapping

Please refer to [Figure 8-1 “SAM3U Memory Mapping” on page 28](#) .

All the peripherals are in the bit band region and are mapped in the bit band alias region.

## 9.2 Power-on-Reset, Brownout and Supply Monitor

The SAM3U embeds three features to monitor, warn and/or reset the chip:

- Power-on-Reset on VDDDBU
- Brownout Detector on VDDCORE
- Supply Monitor on VDDUTMI

### 9.2.1 Power-on-Reset on VDDDBU

The Power-on-Reset monitors VDDDBU. It is always activated and monitors voltage at start up but also during power down. If VDDDBU goes below the threshold voltage, the entire chip is reset. For more information, refer to the Electrical Characteristics section of the datasheet.

### 9.2.2 Brownout Detector on VDDCORE

The Brownout Detector monitors VDDCORE. It is active by default. It can be deactivated by software through the Supply Controller (SUPC\_MR). It is especially recommended to disable it during low-power modes such as wait or sleep modes.

If VDDCORE goes below the threshold voltage, the reset of the core is asserted. For more information, refer to the Supply Controller (SUPC) and Electrical Characteristics sections of the datasheet.

### 9.2.3 Supply Monitor on VDDUTMI

The Supply Monitor monitors VDDUTMI. It is not active by default. It can be activated by software and is fully programmable with 16 steps for the threshold (between 1.9V to 3.4V). It is controlled by the Supply Controller (SUPC). A sample mode is possible. It allows to divide the supply monitor power consumption by a factor of up to 2048. For more information, refer to the SUPC and Electrical Characteristics sections of the datasheet.

## 9.3 Reset Controller

The Reset Controller is capable to return to the software the source of the last reset, either a general reset, a wake-up reset, a software reset, a user reset or a watchdog reset.

The Reset Controller controls the internal resets of the system and the NRST pin output. It is capable to shape a reset signal for the external devices, simplifying to a minimum connection of a push-button on the NRST pin to implement a manual reset.

## 9.4 Supply Controller

The Supply Controller controls the power supplies of each section of the processor and the peripherals (via Voltage regulator control).

The Supply Controller has its own reset circuitry and is clocked by the 32 kHz Slow clock generator.

The reset circuitry is based on a zero-power power-on reset cell. The zero-power power-on reset allows the Supply Controller to start properly.

The Slow Clock generator is based on a 32 kHz crystal oscillator and an embedded 32 kHz RC oscillator. The Slow Clock defaults to the RC oscillator, but the software can enable the crystal oscillator and select it as the Slow Clock source.

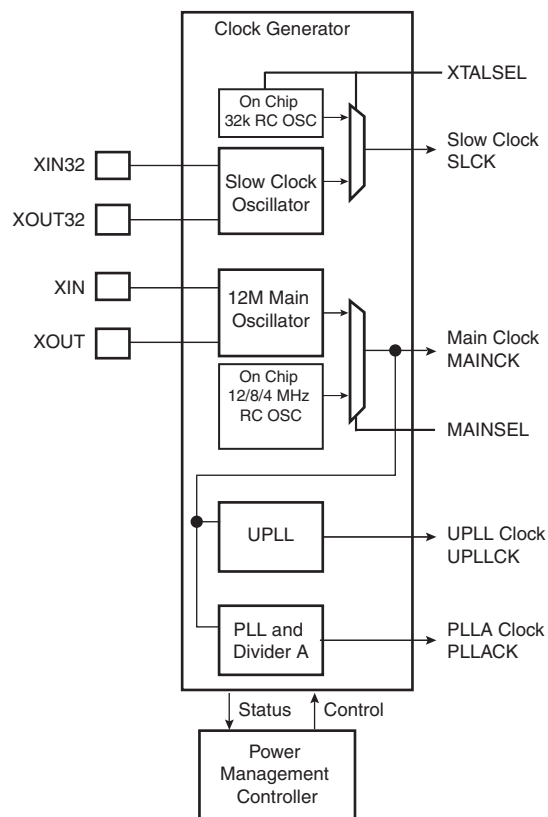
The Supply Controller starts up the device by enabling the Voltage Regulator, then it generates the proper reset signals to the core power supply. It also enables to set the system in different low power modes and to wake it up from a wide range of events.

## 9.5 Clock Generator

The Clock Generator is made up of:

- One Low Power 32768 Hz Slow Clock Oscillator with bypass mode
- One Low Power RC Oscillator
- One 3 to 20 MHz Crystal Oscillator, which can be bypassed
- One Fast RC Oscillator factory programmed, 3 output frequencies can be selected: 4, 8 or 12 MHz. By default 4 MHz is selected. 8 MHz and 12 MHz output are factory calibrated.
- One 480 MHz UPLL providing a clock for the USB High Speed Device Controller. Input frequency is 12 MHz (only).
- One 96 to 192 MHz programmable PLL (PLL A), capable to provide the clock MCK to the processor and to the peripherals. The input frequency of the PLL A is between 8 and 16 MHz.

**Figure 9-2.** Clock Generator Block Diagram



## 9.6 Power Management Controller

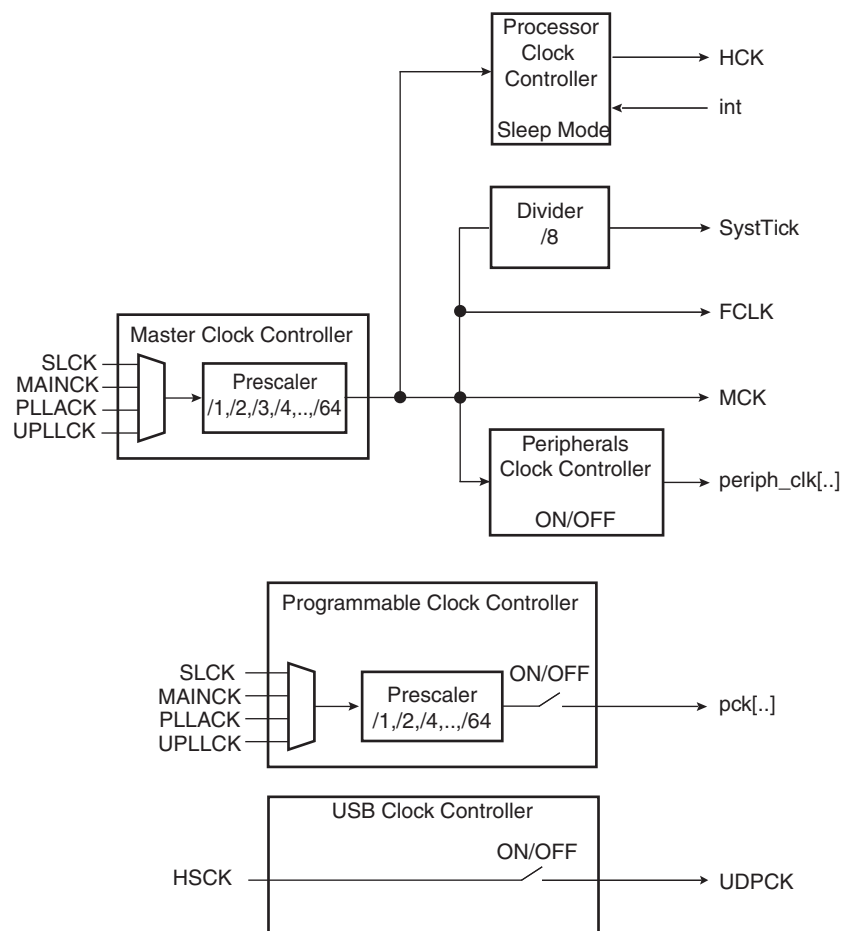
The Power Management Controller provides all the clock signals to the system. It provides:

- the Processor Clock HCLK
- the Free running processor clock FCLK
- the Cortex SysTick external clock
- the Master Clock MCK, in particular to the Matrix and the memory interfaces
- the USB Device HS Clock UDPCK
- independent peripheral clocks, typically at the frequency of MCK
- three programmable clock outputs: PCK0, PCK1 and PCK2

The Supply Controller selects between the 32 kHz RC oscillator or the crystal oscillator. The unused oscillator is disabled automatically so that power consumption is optimized.

By default, at startup the chip runs out of the Master Clock using the Fast RC Oscillator running at 4 MHz.

**Figure 9-3.** Power Management Controller Block Diagram



The SysTick calibration value is fixed at 10500, which allows the generation of a time base of 1 ms with SysTick clock to 10.5 MHz (max HCLK/8).

## 9.7 Watchdog Timer

- 16-bit key-protected once-only Programmable Counter
- Windowed, prevents the processor to be in a dead-lock on the watchdog access

## 9.8 SysTick Timer

- 24-bit down counter
- Self-reload capability
- Flexible system timer

## 9.9 Real-time Timer

- Real-time Timer, allowing backup of time with different accuracies
  - 32-bit Free-running back-up Counter
  - Integrates a 16-bit programmable prescaler running on slow clock
  - Alarm Register capable to generate a wake-up of the system

## 9.10 Real-time Clock

- Low power consumption
- Full asynchronous design
- Two hundred year calendar
- Programmable Periodic Interrupt
- Alarm and update parallel load
- Control of alarm and update Time/Calendar Data In

## 9.11 General-Purpose Back-up Registers

- Eight 32-bit general-purpose backup registers

## 9.12 Nested Vectored Interrupt Controller

- Thirty maskable interrupts
- Sixteen priority levels
- Dynamic reprioritization of interrupts
- Priority grouping
  - selection of preempting interrupt levels and non preempting interrupt levels.
- Support for tail-chaining and late arrival of interrupts.
  - back-to-back interrupt processing without the overhead of state saving and restoration between interrupts.
- Processor state automatically saved on interrupt entry, and restored on
  - interrupt exit, with no instruction overhead.

## 9.13 Chip Identification

- Chip Identifier (CHIPID) registers permit recognition of the device and its revision.

**Table 9-1.** SAM3U Chip IDs Register

Chip Name	Flash Size KByte	Pin Count	CHIPID_CIDR	CHIPID_EXID
SAM3U4C (Rev A)	256	100	0x28000960	0x0
SAM3U2C (Rev A)	128	100	0x280A0760	0x0
SAM3U1C (Rev A)	64	100	0x28090560	0x0
SAM3U4E (Rev A)	256	144	0x28100960	0x0
SAM3U2E (Rev A)	128	144	0x281A0760	0x0
SAM3U1E (Rev A)	64	144	0x28190560	0x0

- JTAG ID: 0x0582A03F

## 9.14 PIO Controllers

- 3 PIO Controllers, PIOA, PIOB, and PIOC, controlling a maximum of 96 I/O Lines
- Each PIO Controller controls up to 32 programmable I/O Lines
  - PIOA has 32 I/O Lines
  - PIOB has 32 I/O Lines
  - PIOC has 32 I/O Lines
- Fully programmable through Set/Clear Registers
- Multiplexing of two peripheral functions per I/O Line
- For each I/O Line (whether assigned to a peripheral or used as general purpose I/O)
  - Input change, rising edge, falling edge, low level and level interrupt
  - Debouncing and Glitch filter
  - Multi-drive option enables driving in open drain
  - Programmable pull up on each I/O line
  - Pin data status register, supplies visibility of the level on the pin at any time
- Synchronous output, provides Set and Clear of several I/O lines in a single write

## 10. Peripherals

### 10.1 Peripheral Identifiers

Table 10-1 defines the Peripheral Identifiers of the SAM3U. A peripheral identifier is required for the control of the peripheral interrupt with the Nested Vectored Interrupt Controller and for the control of the peripheral clock with the Power Management Controller.

Note that some Peripherals are always clocked. Please refer to the table below.

**Table 10-1.** Peripheral Identifiers

Instance ID	Instance Name	NVIC Interrupt	PMC Clock Control	Instance Description
0	SUPC	X		Supply Controller
1	RSTC	X		Reset Controller
2	RTC	X		Real Time Clock
3	RTT	X		Real Time Timer
4	WDT	X		Watchdog Timer
5	PMC	X		Power Management Controller
6	EEFC0	X		Enhanced Embedded Flash Controller 0
7	EEFC1	X		Enhanced Embedded Flash Controller 1
8	UART	X	X	Universal Asynchronous Receiver Transmitter
9	SMC	X	X	Static Memory Controller
10	PIOA	X	X	Parallel I/O Controller A,
11	PIOB	X	X	Parallel I/O Controller B
12	PIOC	X	X	Parallel I/O Controller C
13	USART0	X	X	USART 0
14	USART1	X	X	USART 1
15	USART2	X	X	USART 2
16	USART3	X	X	USART 3
17	HSMCI	X	X	High Speed Multimedia Card Interface
18	TWI0	X	X	Two-Wire Interface 0
19	TWI1	X	X	Two-Wire Interface 1
20	SPI	X	X	Serial Peripheral Interface
21	SSC	X	X	Synchronous Serial Controller
22	TC0	X	X	Timer Counter 0
23	TC1	X	X	Timer Counter 1
24	TC2	X	X	Timer Counter 2
25	PWM	X	X	Pulse Width Modulation Controller
26	ADC12B	X	X	12-bit ADC Controller
27	ADC	X	X	10-bit ADC Controller
28	DMAC	X	X	DMA Controller
29	UDPHS	X	X	USB Device High Speed

## 10.2 Peripheral Signal Multiplexing on I/O Lines

The SAM3U features 3 PIO controllers, PIOA, PIOB and PIOC that multiplex the I/O lines of the peripheral set.

Each PIO Controller controls up to 32 lines. Each line can be assigned to one of two peripheral functions, A or B. The multiplexing tables in the following pages define how the I/O lines of peripherals A and B are multiplexed on the PIO Controllers. The two columns “Extra Function” and “Comments” have been inserted in this table for the user’s own comments, they may be used to track how pins are defined in an application.

Note that some peripheral functions which are output only, might be duplicated within the tables.

## 10.2.1 PIO Controller A Multiplexing

**Table 10-2.** Multiplexing on PIO Controller A (PIOA)

I/O Line	Peripheral A	Peripheral B	Extra Function	Comments
PA0	TIOB0	NPCS1	WKUP0 <sup>(1)(2)</sup>	
PA1	TIOA0	NPCS2	WKUP1 <sup>(1)(2)</sup>	
PA2	TCLK0	AD12BTRG	WKUP2 <sup>(1)(2)</sup>	
PA3	MCCK	PCK1		
PA4	MCCDA	PWMH0		
PA5	MCDA0	PWMH1		
PA6	MCDA1	PWMH2		
PA7	MCDA2	PWML0		
PA8	MCDA3	PWML1		
PA9	TWD0	PWML2	WKUP3 <sup>(1)(2)</sup>	
PA10	TWCK0	PWML3	WKUP4 <sup>(1)(2)</sup>	
PA11	URXD	PWMFI0		
PA12	UTXD	PWMFI1		
PA13	MISO			
PA14	MOSI			
PA15	SPCK	PWMH2		
PA16	NPCS0	NCS1	WKUP5 <sup>(1)(2)</sup>	
PA17	SCK0	ADTRG	WKUP6 <sup>(1)(2)</sup>	
PA18	TXD0	PWMFI2	WKUP7 <sup>(1)(2)</sup>	
PA19	RXD0	NPCS3	WKUP8 <sup>(1)(2)</sup>	
PA20	TXD1	PWMH3	WKUP9 <sup>(1)(2)</sup>	
PA21	RXD1	PCK0	WKUP10 <sup>(1)(2)</sup>	
PA22	TXD2	RTS1	AD12B0	
PA23	RXD2	CTS1		
PA24	TWD1	SCK1	WKUP11 <sup>(1)(2)</sup>	
PA25	TWCK1	SCK2	WKUP12 <sup>(1)(2)</sup>	
PA26	TD	TCLK2		
PA27	RD	PCK0		
PA28	TK	PWMH0		
PA29	RK	PWMH1		
PA30	TF	TIOA2	AD12B1	
PA31	RF	TIOB2		

Notes: 1. Wake-Up source in Backup mode (managed by the SUPC).  
 2. Fast Start-Up source in Wait mode (managed by the PMC).

## 10.2.2 PIO Controller B Multiplexing

**Table 10-3.** Multiplexing on PIO Controller B (PIOB)

I/O Line	Peripheral A	Peripheral B	Extra Function	Comments
PB0	PWMH0	A2	WKUP13 <sup>(1)(2)</sup>	
PB1	PWMH1	A3	WKUP14 <sup>(1)(2)</sup>	
PB2	PWMH2	A4	WKUP15 <sup>(1)(2)</sup>	
PB3	PWMH3	A5	AD12BAB2	
PB4	TCLK1	A6	AD12BAB3	
PB5	TIOA1	A7	AD0	
PB6	TIOB1	D15	AD1	
PB7	RTS0	A0/NBS0	AD2	
PB8	CTS0	A1	AD3	
PB9	D0	DTR0		
PB10	D1	DSR0		
PB11	D2	DCD0		
PB12	D3	RI0		
PB13	D4	PWMH0		
PB14	D5	PWMH1		
PB15	D6	PWMH2		
PB16	D7	PWMH3		
PB17	NANDOE	PWML0		
PB18	NANDWE	PWML1		
PB19	NRD	PWML2		
PB20	NCS0	PWML3		
PB21	A21/NANDALE	RTS2		
PB22	A22/NANDCLE	CTS2		
PB23	NWR0/NWE	PCK2		
PB24	NANDRDY	PCK1		
PB25	D8	PWML0		Only on 144-pin version
PB26	D9	PWML1		Only on 144-pin version
PB27	D10	PWML2		Only on 144-pin version
PB28	D11	PWML3		Only on 144-pin version
PB29	D12			Only on 144-pin version
PB30	D13			Only on 144-pin version
PB31	D14			Only on 144-pin version

- Notes: 1. Wake-Up source in Backup mode (managed by the SUPC).  
 2. Fast Start-Up source in Wait mode (managed by the PMC).

## 10.2.3 PIO Controller C Multiplexing

**Table 10-4.** Multiplexing on PIO Controller C (PIOC)

I/O Line	Peripheral A	Peripheral B	Extra function	Comments
PC0	A2			Only on 144-pin version
PC1	A3			Only on 144-pin version
PC2	A4			Only on 144-pin version
PC3	A5	NPCS1		Only on 144-pin version
PC4	A6	NPCS2		Only on 144-pin version
PC5	A7	NPCS3		Only on 144-pin version
PC6	A8	PWML0		Only on 144-pin version
PC7	A9	PWML1		Only on 144-pin version
PC8	A10	PWML2		Only on 144-pin version
PC9	A11	PWML3		Only on 144-pin version
PC10	A12	CTS3		Only on 144-pin version
PC11	A13	RTS3		Only on 144-pin version
PC12	NCS1	TXD3		Only on 144-pin version
PC13	A2	RXD3		Only on 144-pin version
PC14	A3	NPCS2		Only on 144-pin version
PC15	NWR1/NBS1		AD12B4	Only on 144-pin version
PC16	NCS2	PWML3	AD12B5	Only on 144-pin version
PC17	NCS3		AD12B6	Only on 144-pin version
PC18	NWAIT		AD12B7	Only on 144-pin version
PC19	SCK3	NPCS1		Only on 144-pin version
PC20	A14			Only on 144-pin version
PC21	A15			Only on 144-pin version
PC22	A16			Only on 144-pin version
PC23	A17			Only on 144-pin version
PC24	A18	PWMH0		Only on 144-pin version
PC25	A19	PWMH1		Only on 144-pin version
PC26	A20	PWMH2		Only on 144-pin version
PC27	A23	PWMH3		Only on 144-pin version
PC28		MCDA4	AD4	Only on 144-pin version
PC29	PWML0	MCDA5	AD5	Only on 144-pin version
PC30	PWML1	MCDA6	AD6	Only on 144-pin version
PC31	PWML2	MCDA7	AD7	Only on 144-pin version

- Notes: 1. Wake-Up source in Backup mode (managed by the SUPC).  
 2. Fast Start-Up source in Wait mode (managed by the PMC).

## 11. Embedded Peripherals Overview

### 11.1 Serial Peripheral Interface (SPI)

- Supports communication with serial external devices
  - Four chip selects with external decoder support allow communication with up to 15 peripherals
  - Serial memories, such as DataFlash and 3-wire EEPROMs
  - Serial peripherals, such as ADCs, DACs, LCD Controllers, CAN Controllers and Sensors
  - External co-processors
- Master or slave serial peripheral bus interface
  - 8- to 16-bit programmable data length per chip select
  - Programmable phase and polarity per chip select
  - Programmable transfer delays between consecutive transfers and between clock and data per chip select
  - Programmable delay between consecutive transfers
  - Selectable mode fault detection
- Very fast transfers supported
  - Transfers with baud rates up to MCK
  - The chip select line may be left active to speed up transfers on the same device

### 11.2 Two Wire Interface (TWI)

- Master, Multi-Master and Slave Mode Operation
- Compatibility with Atmel two-wire interface, serial memory and I<sup>2</sup>C compatible devices
- One, two or three bytes for slave address
- Sequential read/write operations
- Bit Rate: Up to 400 kbit/s
- General Call Supported in Slave Mode
- Connecting to PDC channel capabilities optimizes data transfers in Master Mode only
  - One channel for the receiver, one channel for the transmitter
  - Next buffer support

### 11.3 Universal Asynchronous Receiver Transceiver (UART)

- Two-pin UART
  - Implemented features are 100% compatible with the standard Atmel USART
  - Independent receiver and transmitter with a common programmable Baud Rate Generator
  - Even, Odd, Mark or Space Parity Generation
  - Parity, Framing and Overrun Error Detection
  - Automatic Echo, Local Loopback and Remote Loopback Channel Modes
  - Support for two PDC channels with connection to receiver and transmitter

## 11.4 Universal Synchronous Asynchronous Receiver Transmitter (USART)

- Programmable Baud Rate Generator
- 5- to 9-bit full-duplex synchronous or asynchronous serial communications
  - 1, 1.5 or 2 stop bits in Asynchronous Mode or 1 or 2 stop bits in Synchronous Mode
  - Parity generation and error detection
  - Framing error detection, overrun error detection
  - MSB- or LSB-first
  - Optional break generation and detection
  - By 8 or by-16 over-sampling receiver frequency
  - Hardware handshaking RTS-CTS
  - Receiver time-out and transmitter timeguard
  - Optional Multi-drop Mode with address generation and detection
  - Optional Manchester Encoding
- RS485 with driver control signal
- ISO7816, T = 0 or T = 1 Protocols for interfacing with smart cards
  - NACK handling, error counter with repetition and iteration limit
- SPI Mode
  - Master or Slave
  - Serial Clock programmable Phase and Polarity
  - SPI Serial Clock (SCK) Frequency up to MCK/4
- IrDA modulation and demodulation
  - Communication at up to 115.2 Kbps
- Test Modes
  - Remote Loopback, Local Loopback, Automatic Echo

## 11.5 Serial Synchronous Controller (SSC)

- Provides serial synchronous communication links used in audio and telecom applications (with CODECs in Master or Slave Modes, I<sup>2</sup>S, TDM Buses, Magnetic Card Reader, ...)
- Contains an independent receiver and transmitter and a common clock divider
- Offers a configurable frame sync and data length
- Receiver and transmitter can be programmed to start automatically or on detection of different event on the frame sync signal
- Receiver and transmitter include a data signal, a clock signal and a frame synchronization signal

## 11.6 Timer Counter (TC)

- Three 16-bit Timer Counter Channels
- Wide range of functions including:
  - Frequency Measurement
  - Event Counting
  - Interval Measurement

- Pulse Generation
- Delay Timing
- Pulse Width Modulation
- Up/Down Capabilities
- Quadruple Decoder Logic
- Each channel is user-configurable and contains:
  - Three external clock inputs
  - Five internal clock inputs
  - Two multi-purpose input/output signals
- Two global registers that act on all three TC Channels

## 11.7 Pulse Width Modulation Controller (PWM)

- 4 channels, one 16-bit counter per channel
- Common clock generator, providing Thirteen Different Clocks
  - A Modulo n counter providing eleven clocks
  - Two independent Linear Dividers working on modulo n counter outputs
  - High Frequency Asynchronous clocking mode
- Independent channel programming
  - Independent Enable Disable Commands
  - Independent Clock Selection
  - Independent Period and Duty Cycle, with Double Buffering
  - Programmable selection of the output waveform polarity
  - Programmable center or left aligned output waveform
  - Independent Output Override for each channel
  - Independent complementary Outputs with 12-bit dead time generator for each channel
  - Independent Enable Disable Commands
  - Independent Clock Selection
  - Independent Period and Duty Cycle, with Double Buffering
- Synchronous Channel mode
  - Synchronous Channels share the same counter
  - Mode to update the synchronous channels registers after a programmable number of periods
- Connection to one PDC channel
  - Offers Buffer transfer without Processor Intervention, to update duty cycle of synchronous channels
- Two independent event lines which can send up to 8 triggers on ADC within a period
- Four programmable Fault Inputs providing asynchronous protection of outputs

## 11.8 High Speed Multimedia Card Interface (HSMCI)

- Compatibility with MultiMedia Card Specification Version 4.3
- Compatibility with SD Memory Card Specification Version 2.0
- Compatibility with SDIO Specification Version V2.0.
- Compatibility with CE-ATA Specification 1.1
- Cards clock rate up to Master Clock divided by 2
- Boot Operation Mode support
- High Speed mode support
- Embedded power management to slow down clock rate when not used
- HSMCI has one slot supporting
  - One MultiMediaCard bus (up to 30 cards) or
  - One SD Memory Card
  - One SDIO Card
- Support for stream, block and multi-block data read and write
- Supports Connection to DMA controller
  - Minimizes Processor intervention for large buffer transfers
- Built in FIFO (32 bytes) with large Memory Aperture Supporting Incremental access
- Support for CE-ATA Completion Signal Disable Command

## 11.9 USB High Speed Device Port (UDPHS)

- USB V2.0 high-speed compliant, 480 Mbits per second
- Embedded USB V2.0 UTMI+ high-speed transceiver
- Embedded 4-Kbyte dual-port RAM for endpoints
- Embedded 6 channels DMA controller
- Suspend/Resume logic
- Up to 2 or 3 banks for isochronous and bulk endpoints
- Seven endpoints, configurable by software
- Maximum configuration: seven endpoints:
  - Endpoint 0: 64 bytes, 1 bank mode
  - Endpoint 1 & 2: 512 bytes, 2 banks mode, HS isochronous capable
  - Endpoint 3 & 4: 64 bytes, 3 banks mode
  - Endpoint 5 & 6: 1024 bytes, 3 banks mode, HS isochronous capable

## 11.10 Analog-to-Digital Converter (ADC)

Two ADCs are embedded in the product. ADC0 is a high speed 12-bit 1 Msamples/sec. ADC1 is a low power 10-bit 460 Ksamples/sec.

### 11.10.1 ADC0: 12-bit ADC

- 8-channel ADC
- 12-bit 1 Msamples/sec. or 10-bit 2 Msamples/sec. Cyclic Pipeline ADC
- Integrated 8-to-1 multiplexer
- 12-bit resolution

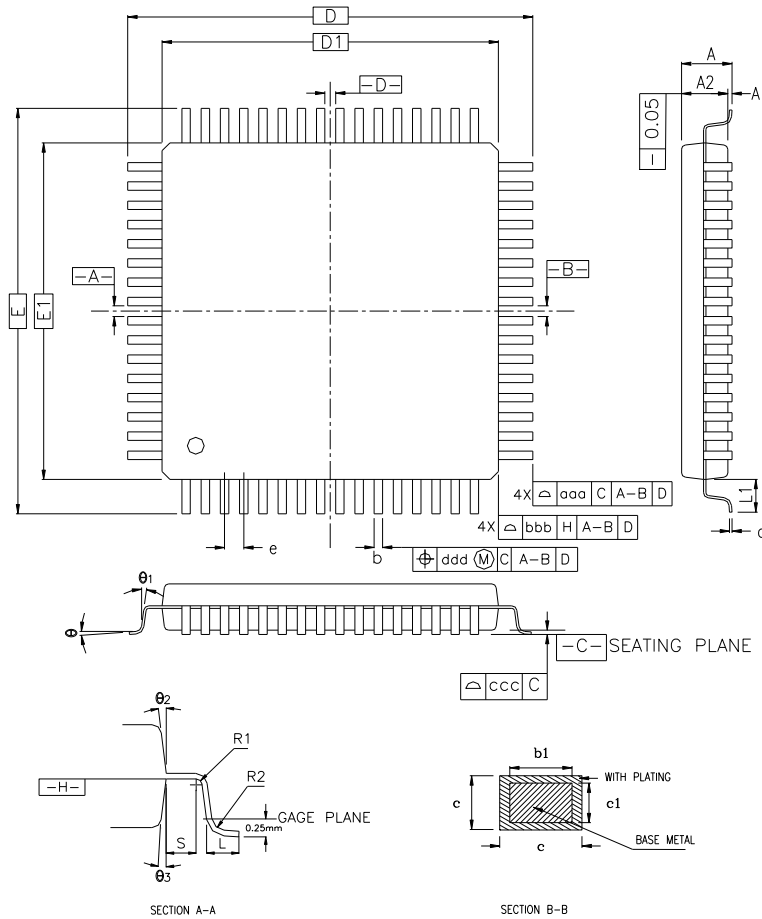
- Selectable single ended or differential input voltage
- Programmable gain for maximum full scale input range
- External voltage reference for better accuracy on low voltage inputs
- Individual enable and disable of each channel
- Multiple trigger sources
  - Hardware or software trigger
  - External trigger pin
  - Timer Counter 0 to 2 outputs TIOA0 to TIOA2 trigger
  - PWM trigger
- Sleep Mode and conversion sequencer
  - Automatic wakeup on trigger and back to sleep mode after conversions of all enabled channels

#### 11.10.2 ADC1: 10-bit ADC

- 8-channel ADC
- 10-bit 460 Ksamples/sec. or 8-bit 660 Ksamples/sec. Successive Approximation Register ADC
- -2/+2 LSB Integral Non Linearity, -1/+1 LSB Differential Non Linearity
- Integrated 8-to-1 multiplexer
- External voltage reference for better accuracy on low voltage inputs
- Individual enable and disable of each channel
- Multiple trigger sources
  - Hardware or software trigger
  - External trigger pin
  - Timer Counter 0 to 2 outputs TIOA0 to TIOA2 trigger
  - PWM trigger
- Sleep Mode and conversion sequencer
  - Automatic wakeup on trigger and back to sleep mode after conversions of all enabled channels

## 12. Package Drawings

Figure 12-1. 100-ball LQFP Package Mechanical Drawing



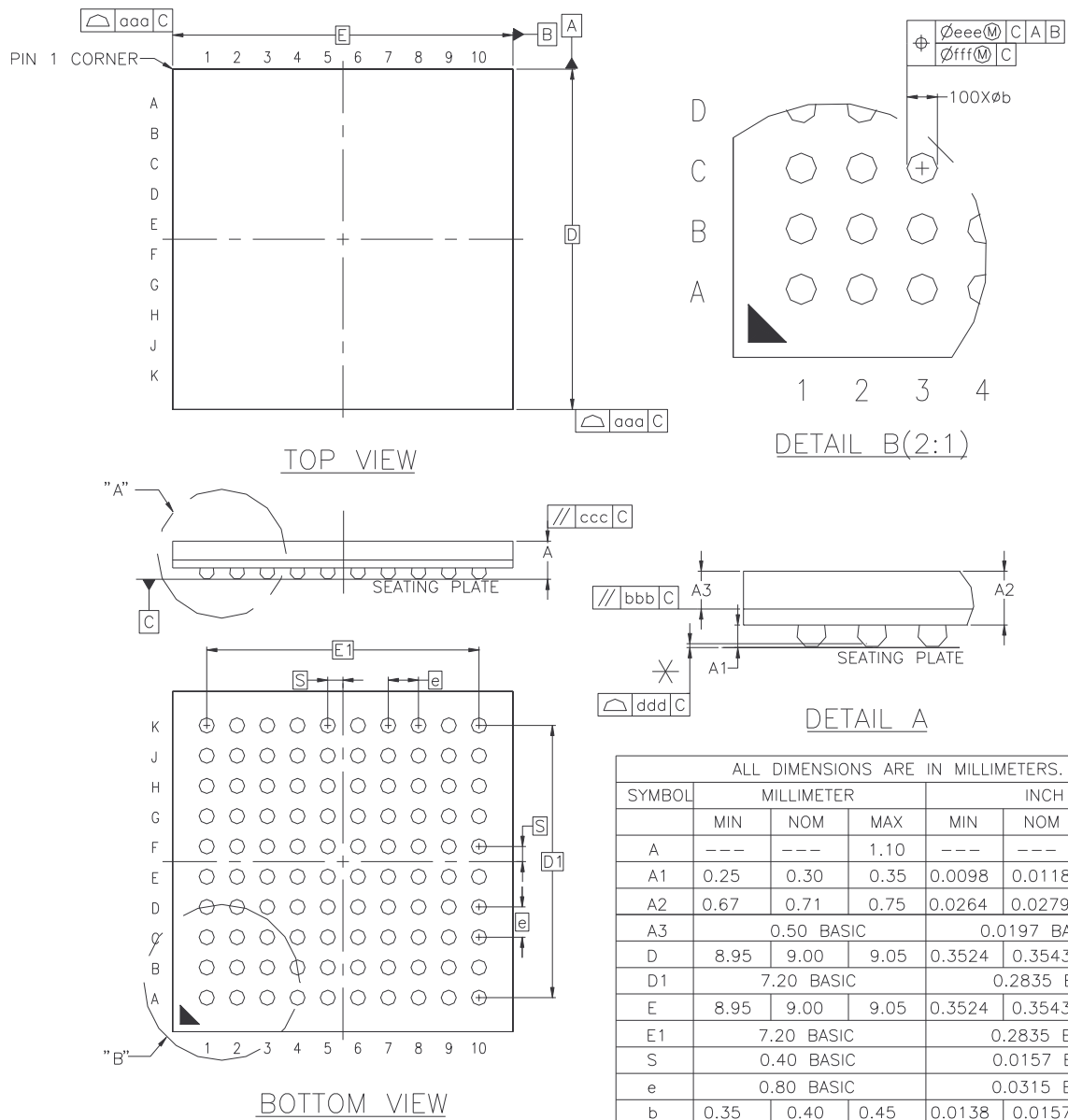
CONTROL DIMENSIONS ARE IN MILLIMETERS.

SYMBOL	MILLIMETER			INCH		
	MIN.	NOM.	MAX.	MIN.	NOM.	MAX.
A	—	—	1.60	—	—	0.063
A1	0.05	—	0.15	0.002	—	0.006
A2	1.35	1.40	1.45	0.053	0.055	0.057
D	16.00 BSC.			0.630 BSC.		
D1	14.00 BSC.			0.551 BSC.		
E	16.00 BSC.			0.630 BSC.		
E1	14.00 BSC.			0.551 BSC.		
R2	0.08	—	0.20	0.003	—	0.008
R1	0.08	—	—	0.003	—	—
$\theta$	0°	3.5°	7°	0°	3.5°	7°
$\theta_1$	0°	—	—	0°	—	—
$\theta_2$	11°	12°	13°	11°	12°	13°
$\theta_3$	11°	12°	13°	11°	12°	13°
c	0.09	—	0.20	0.004	—	0.008
c1	0.09	0.127	0.16	0.004	0.005	0.006
L1	1.00 REF			0.039 REF		
L	0.45	0.60	0.75	0.018	0.024	0.030
S	0.20	—	—	0.008	—	—
b	0.17	—	0.27	0.007	—	0.011
b1	0.17	0.20	0.23	0.007	0.008	0.009
e	0.50 BSC.			0.020 BSC.		
TOLERANCES OF FORM AND POSITION						
aaa	0.20			0.008		
bbb	0.20			0.008		
ccc	0.08			0.003		
ddd	0.08			0.003		

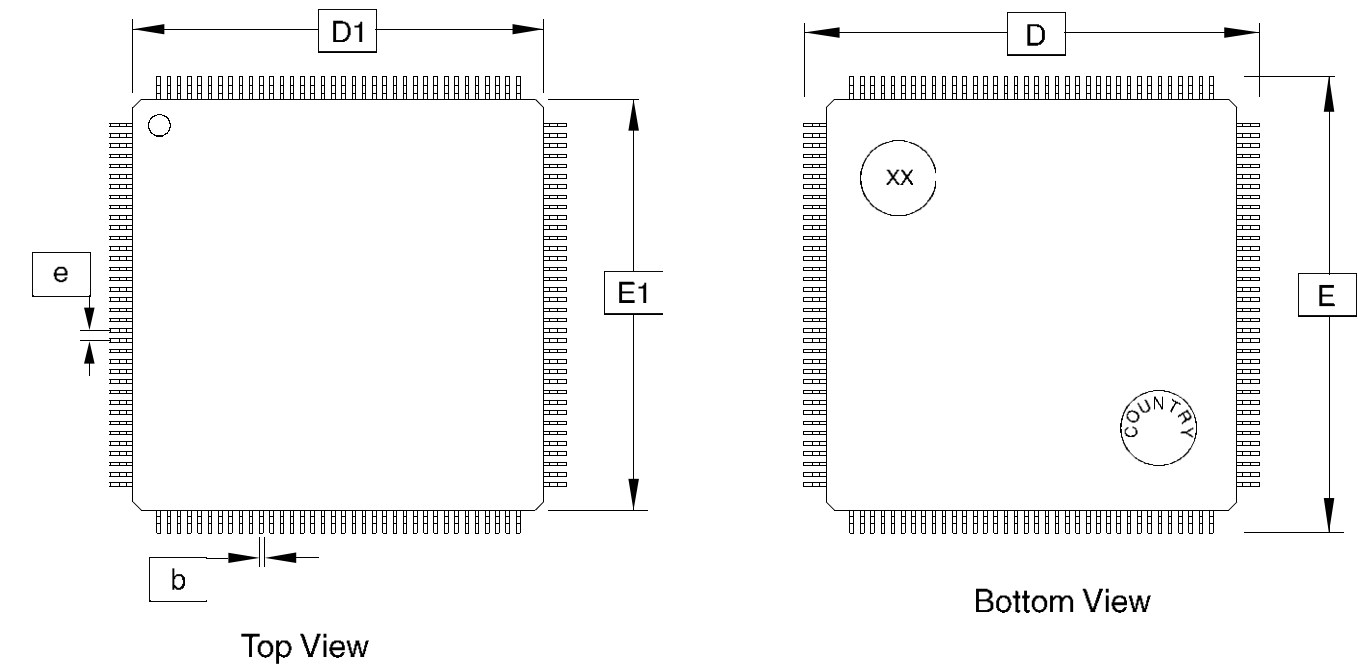
NOTES :

- DIMENSIONS D1 AND E1 DO NOT INCLUDE MOLD PROTRUSION. ALLOWABLE PROTRUSION IS 0.25mm PER SIDE. D1 AND E1 DO INCLUDE MOLD MISMATCH AND ARE DETERMINED AT DATUM PLANE [H]
- DIMENSION b DOES NOT INCLUDE DAMBAR PROTRUSION. ALLOWABLE DAMBAR PROTRUSION SHALL BE 0.08MM TOTAL IN EXCESS OF THE b DIMENSION AT MAXIMUM MATERIAL CONDITION. DAMBAR CAN NOT BE LOCATED ON THE LOWER RADIUS OR THE FOOT

**Figure 12-2. 100-ball LFBGA Package Mechanical Drawing**

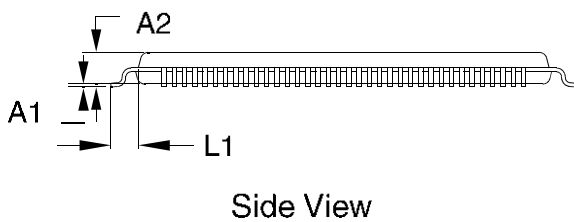


**Figure 12-3.** 144-lead LQFP Package Mechanical Drawing



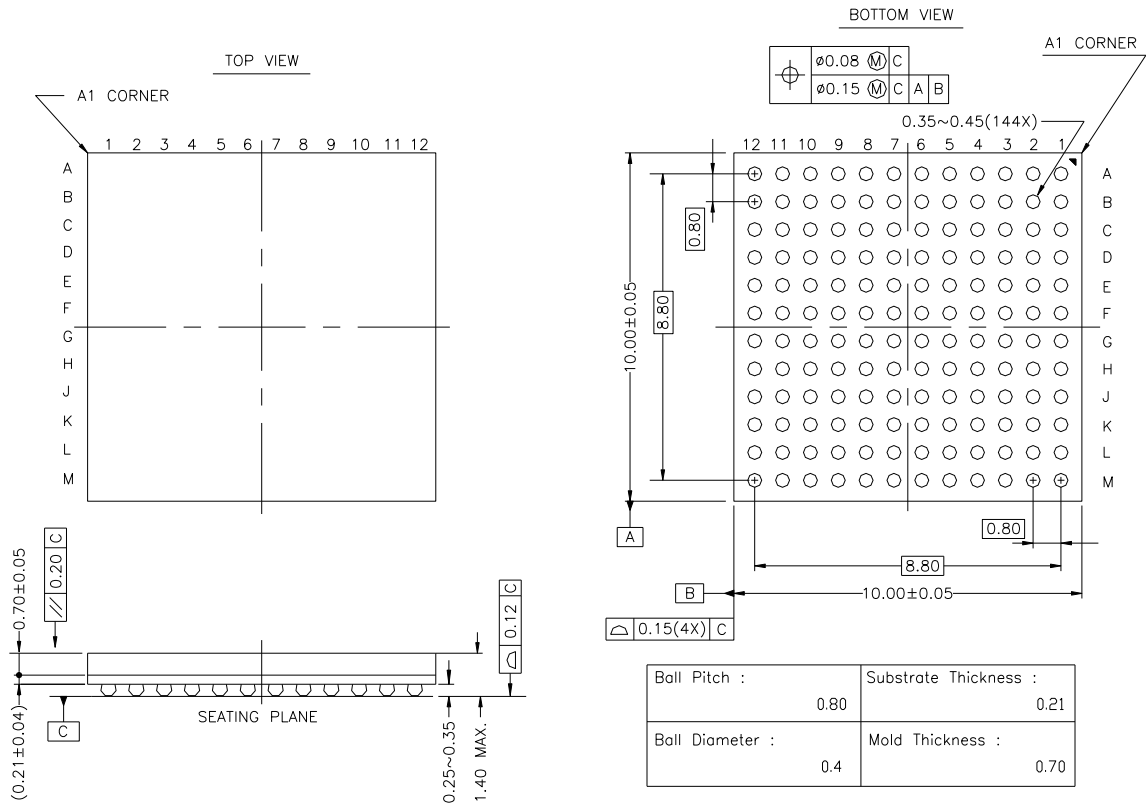
**COMMON DIMENSIONS**  
(Unit of Measure = mm)

SYMBOL	MIN	NOM	MAX	NOTE
A1	0.05		0.15	6
A2	1.35	1.40	1.45	
D	22.00 BSC			
D1	20.00 BSC			2, 3
E	22.00 BSC			
E1	20.00 BSC			2, 3
e	0.50 BSC			
b	0.17	0.22	0.27	4, 5
L1	1.00 REF			



- Notes:
1. This drawing is for general information only; refer to JEDEC Drawing MS-026 for additional information.
  2. The top package body size may be smaller than the bottom package size by as much as 0.15 mm.
  3. Dimensions D1 and E1 do not include mold protrusions. Allowable protrusion is 0.25 mm per side. D1 and E1 are maximum plastic body size dimensions including mold mismatch.
  4. b dimension by more than 0.08 mm. Dambar cannot be located on the lower radius or the foot. Minimum space between protrusion and an adjacent lead is 0.07 mm for 0.4 and 0.5 mm pitch packages.
  5. These dimensions apply to the flat section of the lead between 0.10 mm and 0.25 mm from the lead tip.
  6. A1 is defined as the distance from the seating place to the lowest point on the package body.

Figure 12-4. 144-ball LFBGA Mechanical Drawing



All dimensions are in mm.

## 13. Ordering Information

**Table 13-1.** ATSAM3U4/2/1 Ordering Information

Ordering Code	MRL	Flash (Kbytes)	Package	Package Type	Temperature Operating Range
ATSAM3U4EA-AU	A	256	LQFP144	Green	Industrial -40°C to 85°C
ATSAM3U4EA-CU	A	256	LFBGA 144	Green	Industrial -40°C to 85°C
ATSAM3U4CA-AU	A	256	LQFP 100	Green	Industrial -40°C to 85°C
ATSAM3U4CA-CU	A	256	TFBGA100	Green	Industrial -40°C to 85°C
ATSAM3U2EA-AU	A	128	LQFP144	Green	Industrial -40°C to 85°C
ATSAM3U2EA-CU	A	128	LFBGA144	Green	Industrial -40°C to 85°C
ATSAM3U2CA-AU	A	128	LQFP100	Green	Industrial -40°C to 85°C
ATSAM3U2CA-CU	A	128	TFBGA100	Green	Industrial -40°C to 85°C
ATSAM3U1EA-AU	A	64	LQFP144	Green	Industrial -40°C to 85°C
ATSAM3U1EA-CU	A	64	LFBGA144	Green	Industrial -40°C to 85°C
ATSAM3U1CA-AU	A	64	LQFP100	Green	Industrial -40°C to 85°C
ATSAM3U1CA-CU	A	64	TFBGA100	Green	Industrial -40°C to 85°C



## Revision History

Doc. Rev	Comments	Change Request Ref.
6430AS	First issue	





## Headquarters

---

**Atmel Corporation**  
2325 Orchard Parkway  
San Jose, CA 95131  
USA  
Tel: 1(408) 441-0311  
Fax: 1(408) 487-2600

## International

---

**Atmel Asia**  
Unit 1-5 & 16, 19/F  
BEA Tower, Millennium City 5  
418 Kwun Tong Road  
Kwun Tong, Kowloon  
Hong Kong  
Tel: (852) 2245-6100  
Fax: (852) 2722-1369

**Atmel Europe**  
Le Krebs  
8, Rue Jean-Pierre Timbaud  
BP 309  
78054 Saint-Quentin-en-  
Yvelines Cedex  
France  
Tel: (33) 1-30-60-70-00  
Fax: (33) 1-30-60-71-11

**Atmel Japan**  
9F, Tonetsu Shinkawa Bldg.  
1-24-8 Shinkawa  
Chuo-ku, Tokyo 104-0033  
Japan  
Tel: (81) 3-3523-3551  
Fax: (81) 3-3523-7581

## Product Contact

---

**Web Site**  
[www.atmel.com](http://www.atmel.com)  
[www.atmel.com/AT91SAM](http://www.atmel.com/AT91SAM)

**Technical Support**  
[AT91SAM Support](mailto:AT91SAM_Support@atmel.com)  
[Atmel technical support](mailto:ATmel_techincal_support@atmel.com)

**Sales Contacts**  
[www.atmel.com/contacts/](http://www.atmel.com/contacts/)

**Literature Requests**  
[www.atmel.com/literature](http://www.atmel.com/literature)

---

**Disclaimer:** The information in this document is provided in connection with Atmel products. No license, express or implied, by estoppel or otherwise, to any intellectual property right is granted by this document or in connection with the sale of Atmel products. **EXCEPT AS SET FORTH IN ATMEL'S TERMS AND CONDITIONS OF SALE LOCATED ON ATMEL'S WEB SITE, ATMEL ASSUMES NO LIABILITY WHATSOEVER AND DISCLAIMS ANY EXPRESS, IMPLIED OR STATUTORY WARRANTY RELATING TO ITS PRODUCTS INCLUDING, BUT NOT LIMITED TO, THE IMPLIED WARRANTY OF MERCHANTABILITY, FITNESS FOR A PARTICULAR PURPOSE, OR NON-INFRINGEMENT. IN NO EVENT SHALL ATMEL BE LIABLE FOR ANY DIRECT, INDIRECT, CONSEQUENTIAL, PUNITIVE, SPECIAL OR INCIDENTAL DAMAGES (INCLUDING, WITHOUT LIMITATION, DAMAGES FOR LOSS OF PROFITS, BUSINESS INTERRUPTION, OR LOSS OF INFORMATION) ARISING OUT OF THE USE OR INABILITY TO USE THIS DOCUMENT, EVEN IF ATMEL HAS BEEN ADVISED OF THE POSSIBILITY OF SUCH DAMAGES.** Atmel makes no representations or warranties with respect to the accuracy or completeness of the contents of this document and reserves the right to make changes to specifications and product descriptions at any time without notice. Atmel does not make any commitment to update the information contained herein. Unless specifically provided otherwise, Atmel products are not suitable for, and shall not be used in, automotive applications. Atmel's products are not intended, authorized, or warranted for use as components in applications intended to support or sustain life.



© 2009 Atmel Corporation. All rights reserved. Atmel®, logo and combinations thereof DataFlash®, SAM-BA® and others are registered trademarks or trademarks of Atmel Corporation or its subsidiaries. ARM®, Thumb®-2 and the ARMPowered logo® and others are registered trademarks or trademarks ARM Ltd. Windows® and others are registered trademarks or trademarks of Microsoft Corporation in the US and/or other countries. Other terms and product names may be trademarks of others.