

C4000RW Series

Compact, 2:1 Input 40W, Single Output DC/DC Converters



Key Features:

- 40W Output Power
- 2:1 Input Voltage Range
- 1,500 VDC Isolation
- Compact 2 x 2 In. Case
- -40°C to +60°C Operation
- >1.0 MHour MTBF
- Remote ON/OFF
- Industry Standard Pin-Out



MicroPower Direct

292 Page Street
Suite D
Stoughton, MA 02072
USA

T: (781) 344-8226
F: (781) 344-8481
E: sales@micropowerdirect.com
W: www.micropowerdirect.com



Electrical Specifications

Specifications typical @ +25°C, nominal input voltage & rated output current, unless otherwise noted. Specifications subject to change without notice.

Input

Parameter	Conditions	Min.	Typ.	Max.	Units
Input Voltage Range	12 VDC Input	9.0	12.0	18.0	VDC
	24 VDC Input	18.0	24.0	36.0	
	48 VDC Input	36.0	48.0	75.0	
Under Voltage Shutdown	12 VDC Input	8.0		9.0	VDC
	24 VDC Input	16.0		17.8	
	48 VDC Input	33.0		36.0	
Input Filter	π (Pi) Filter				
Start Up Time	See Note 1			2.0	A

Output

Parameter	Conditions	Min.	Typ.	Max.	Units
Output Voltage Accuracy			±1.0		%
Line Regulation	For Vin Min to Max		±0.2		%
Load Regulation	Iout = 10% to 100%		±0.5		%
Ripple & Noise (20 MHz) (Note 1)			75	150	mV P - P
Output Power Protection		120		150	%
Over Voltage Protection		110		130	% Vout
Transient Recovery Time (Note 2)	25% Load Step Change		200	500	μSec
Transient Response Deviation				±5.0	%
Temperature Coefficient			±0.02		%/°C
Output Short Circuit	Continuous (Autorecovery)				

General

Parameter	Conditions	Min.	Typ.	Max.	Units
Isolation Voltage	60 Seconds	1,500			VDC
Isolation Resistance	500 VDC	1,000			MΩ
Isolation Capacitance	100 kHz, 0.1V		2,000		pF
Switching Frequency			300		kHz
Over Temperature Protection	Case Temperature		115		°C

Remote On/Off (Note 3)

Parameter	Conditions	Min.	Typ.	Max.	Units
Supply On		3.5		12.0	VDC
Supply Off		-0.0		1.2	VDC
Standby Input Current				1	mA
Control Common	Referenced to Negative Input (pin 2)				

Environmental

Parameter	Conditions	Min.	Typ.	Max.	Units
Operating Temperature Range	Ambient	-40		+60	°C
Storage Temperature Range		-55		+125	°C
Cooling	Free Air Convection				
Humidity	RH, Non-condensing			95	%

Physical

Case Size	2.0 x 2.0 x 0.42 Inches (50.8 x 50.8 x 10.6 mm)				
Case Material	Metal with Non-Conductive Base				
Weight	2.19 Oz (60g)				

Reliability Specifications

Parameter	Conditions	Min.	Typ.	Max.	Units
MTBF	MIL HDBK 217F, 25°C, Gnd Benign	1,000			kHours

Absolute Maximum Ratings

Parameter	Conditions	Min.	Typ.	Max.	Units
Input Voltage Surge (1 Sec)	12 VDC Input	-0.7		20.0	VDC
	24 VDC Input	-0.7		40.0	
	48 VDC Input	-0.7		80.0	
Lead Temperature	1.5 mm From Case For 10 Sec			300	°C

Caution: Exceeding Absolute Maximum Ratings may damage the module. These are not continuous operating ratings.

Model Selection Guide

Model Number	Input				Output			Efficiency (% Typ)	Capacitive Load (μF Max)	Fuse Rating Slow-Blow (mA)
	Voltage (VDC)		Current (mA)		Voltage (VDC)	Current (mA, Max)	Current (mA, Min)			
	Nominal	Range	Full-Load	No-Load						
C4001RW	12	9.0 - 18.0	2,558	20	3.3	8,000	400.0	86	21,000	5,000
C4002RW	12	9.0 - 18.0	3,876	20	5.0	8,000	400.0	86	13,600	5,000
C4003RW	12	9.0 - 18.0	3,876	20	12.0	3,300	165.0	86	2,360	5,000
C4004RW	12	9.0 - 18.0	3,831	20	15.0	2,666	133.0	87	1,510	5,000
C4011RW	24	18.0 - 36.0	1,264	15	3.3	8,000	400.0	87	21,000	3,000
C4012RW	24	18.0 - 36.0	1,873	15	5.0	8,000	400.0	89	13,600	3,000
C4013RW	24	18.0 - 36.0	1,894	15	12.0	3,300	165.0	88	2,360	3,000
C4014RW	24	18.0 - 36.0	1,873	15	15.0	2,666	133.0	88	1,510	3,000
C4021RW	48	36.0 - 75.0	625	10	3.3	8,000	400.0	88	21,000	1,500
C4022RW	48	36.0 - 75.0	926	10	5.0	8,000	400.0	90	13,600	1,500
C4023RW	48	36.0 - 75.0	926	10	12.0	3,300	165.0	90	2,360	1,500
C4024RW	48	36.0 - 75.0	926	10	15.0	2,666	133.0	90	1,510	1,500

Notes:

- When measuring output ripple, it is recommended that an external 10.0 μF ceramic capacitor be placed from the +Vout pin to the -Vout pin. For noise sensitive applications, the use of 47 μF capacitors will reduce the output ripple.
- Transient recovery is measured to within a 1% error band for a load step change of 75% to 100%.
- The Remote On/Off Control input (Pin 3) is referenced to -Vin (Pin 1). Connection to the pin should be made through a 1k Ω resistor and diode (1N4148). If it is not used, the control pin should be left open.
- Operation at no-load will not damage these units. However, they may not meet all specifications.
- The +sense and -sense connections will compensate for up to 5% of Vout. When not used, they should be connected directly to the appropriate output pin (+sense to +Vout and -sense to -Vout).
- To improve performance and stability, a simple external LC filter can be added to the unit input. Typical component values would be 1.0 $\mu\text{H}/10\text{A}$ & 1,000 $\mu\text{F}/25\text{V}$ for 12V input models; 2.2 $\mu\text{H}/10\text{A}$ & 1,000 $\mu\text{F}/50\text{V}$ for 24V input models; and 74.7 $\mu\text{H}/5\text{A}$ & 1,000 $\mu\text{F}/100\text{V}$ for 48V input models.
- It is recommended that a fuse be used on the input of a power supply for protection. See the table above for the correct rating.

External Trim

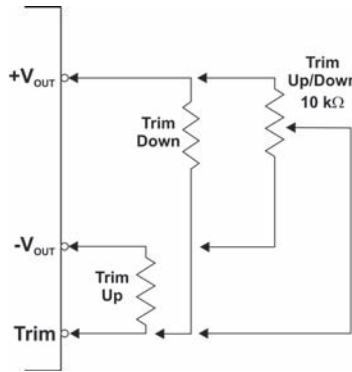

A simple external circuit may be used to adjust the converter output. To adjust the output DOWN, connect a 5%, 3W resistor between the plus output pin and the Vout trim pin. To adjust the output UP, connect a 5%, 3W resistor between the minus output pin and the Vout trim pin. To calculate the correct resistor value (in k Ω) use:

$$3.3 V_{\text{OUT}} \text{ UP } R_{\text{ADJ}} = \frac{(V_{\text{OUT}} - 1.24) \times (2.87)}{V_{\text{ADJ}} - V_{\text{OUT}}} - 10$$

$$\text{Other } V_{\text{OUT}} \text{ UP } R_{\text{ADJ}} = \frac{(V_{\text{OUT}} - 2.5) \times (2.87)}{V_{\text{ADJ}} - V_{\text{OUT}}} - 10$$

$$3.3 V_{\text{OUT}} \text{ Down } R_{\text{ADJ}} = \frac{(V_{\text{ADJ}} - 1.24) (V_{\text{OUT}} - 1.24) \times 2.87}{V_{\text{OUT}} - V_{\text{ADJ}}} - 10$$

$$\text{Other } V_{\text{OUT}} \text{ Down } R_{\text{ADJ}} = \frac{(V_{\text{ADJ}} - 2.5) (V_{\text{OUT}} - 2.5) \times 2.87}{V_{\text{OUT}} - V_{\text{ADJ}}} - 10$$

For UP/Down trimming capability, connect a 10 kW potentiometer between the plus and minus outputs with the wiper arm connected to the Vout trim pin.

Mechanical Dimensions

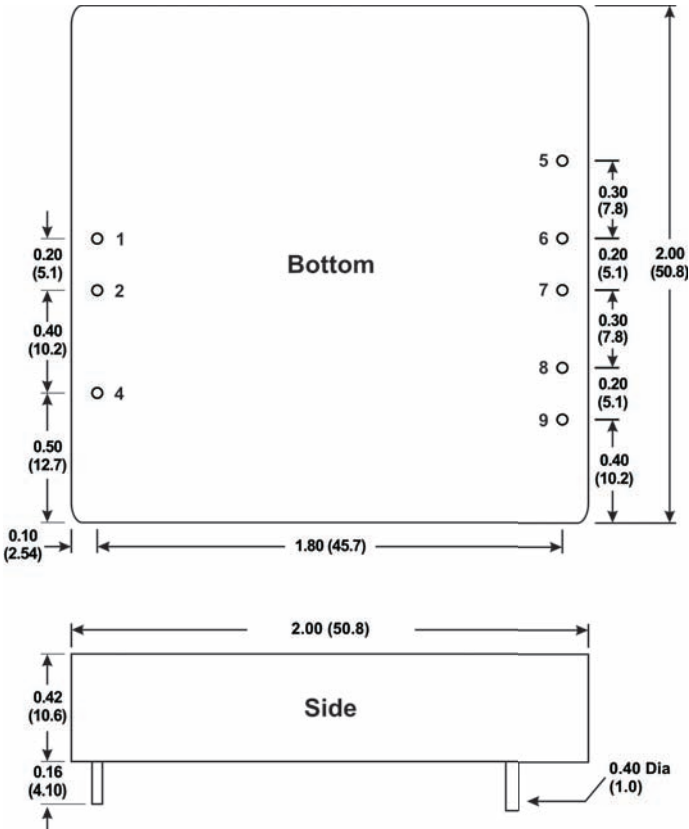

Derating Curves

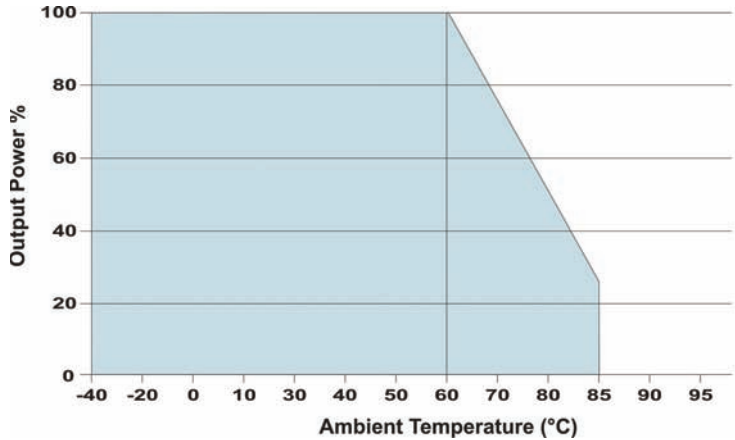

Pin Connections

Pin	Single	Pin	Single
1	+Vin	6	+Sense
2	-Vin	7	+Vout
4	ON/OFF	8	-Vout
5	-Sense	9	Trim

Mechanical Notes:

- All dimensions are typical in inches (mm)
- Tolerance x.xx = ± 0.01 (± 0.25)



MicroPower Direct

www.micropowerdirect.com