

LCD MODULE
(DEPARTMENT)

SPECIFICATION

G2432W32SBN10 – REV. 1

Preliminary

CUSTOMER APPROVAL
“STAMP AND SIGNATURE”
DATE: _____

IMPORTANT NOTE: This document must be approved by customer and send back to CCT by mail, email or fax. If the approved document is not returned, CCT will assume it has been approved if any Mass Production Order is issued subsequently.

	Designation	Name	Signature/Date
Originator	Electronic Engineer	Zaifulnihar B. Mat Jailaini	09-03-2007
Checked by	Software Engineer	Christopher Choong	09-03-2007
Approved by	Project Manager	Azhar Rosdi	09-03-2007



LCD Module Specification

1.0 Table of Contents

	Page
1. Contents	1
2. Record of revision	2
3. General specification	3
4. Absolute maximum ratings	4
5. Electrical characteristics	4
6. Environmental requirement	4
7. LCD specification	5 ~ 6
8. Interfacing	7
9. Timing characteristics	8 ~ 10
10. Power supply	11
11. Block diagram	11
12. Quality assurance	12 ~ 14
13. Precautions in use LCM	15 ~ 16
15. Outline drawing	17



2.0 Record of revision

Rev	Date	Item	Page	Comment
1	09/03/07			Preliminary



3.0 General specification

Display format: 320 (W) x 240 (H) dots

View area: 92.0mm x 122.0mm

General dimensions: 109.0mm x 160.1mm

- LCD type : TN HTN FSTN
 STN (BLUE)
- Polarizer mode : Reflective Transflective
 Transmissive Negative
- View angle : 6 O'clock 12 O'clock
 9 O'clock 3 O'clock
- Backlight : EL LED CCFL
- Backlight color : Yellow Green Amber White
 Blue Green Others
- Controller : None
 Driver : SPLC086A
- Temperature range : Normal temperature Wide temperature
- Operating 0 to 50 C Operating -20to 70 C
 Storage -20 to 70 C Storage -30 to 80 C

**4.0 Absolute maximum rating** $V_{SS} = 0V, T_a = 25^{\circ}C$

NO	ITEM	SIMBOL	MIN	MAX	UNIT
1.	Power Supply voltage (Logic)	$V_{DD} - V_{SS}$	0	7.0	V
2.	Power Supply voltage (LCD Driver)	$V_{EE} - V_{SS}$	-	28.0	V
3.	Operating Temperature	T_{op}	Refer page 3		$^{\circ}C$
4.	Storage Temperature	T_{st}	Refer page 3		$^{\circ}C$

5.0 Electrical characteristics

NO	ITEM	SYMBOL	CONDITION	MIN	TYP	MAX	UNIT
1.	Power Supply voltage (Logic)	$V_{DD} - V_{SS}$	-	4.5	5.0	5.5	V
2.	Power Supply voltage (V_{LCD})	$V_{EE} - V_{SS}$	$25^{\circ}C$	21.4	23.0	24.4	V
3.	Input Voltage	V_{IH}	-	$0.7V_{DD}$	-	V_{DD}	V
		V_{IL}	-	0	-	$0.3V_{DD}$	V
4.	Voltage supply for Backlight	V_{LED}	-	-	5.0	-	V
5.	Current supply for module	I_{DD}	$V_{DD} - V_{SS} = 5V$	-	7.5	10.0	mA
6.	Current supply for Backlight	I_{LED}	$V_{LED} = 5.0V$ $R_{LED} = 10\Omega$	-	145.0	200.0	mA

6.0 Environmental requirements

NO	ITEM	CONDITION
1.	Operating Temperature	Refer page 3
2.	Storage Temperature	Refer page 3
3.	Operating Humidity	5% to 95%RH
4.	Cycle Test	0 C @ 30 min to 50 C @ 30min for 1 cycle run for 10 cycles

Note: The background on LCD has the possibility to be changed in different temperature range.



7.0 LCD specification

7.1 Electro-optical characteristics

NO	ITEM	SYMBOL	TEMP. °C	CONDITION	COMMERCIAL			UNIT	REF.
					MIN	TYP	MAX		
1	Operating Voltage	V_{LCD}	25	$\theta = 0$ $Cr = \max$	-	23.0	-	Volt	7.1.1
2	Viewing	$\theta_x 1$	25	$CR \geq 2$ $V_{LCD} = 23.0$	-	TBD	-	Deg	7.1.2
		$\theta_x 2$			-	TBD	-		
		$\theta_y 1$			-	TBD	-		
		$\theta_y 2$			-	TBD	-		
3	Contrast Ratio	Cr	25	$\theta = 0^\circ, V_{LCD} = 23.0$	-	TBD	-		7.1.3

- The data above was taken without Touch Panel.

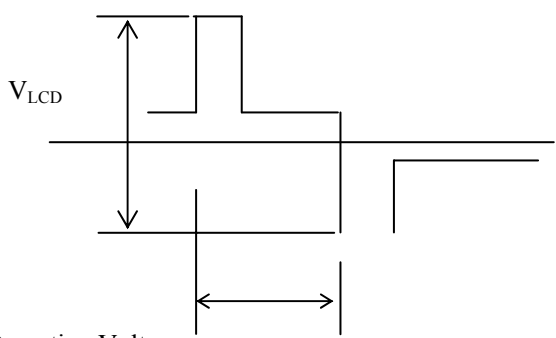
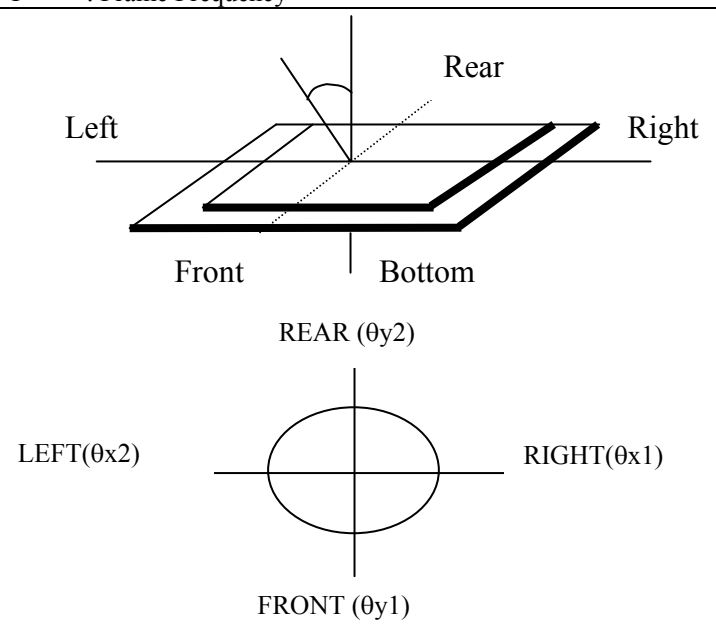
No.	Characteristics	Definition
7.1.1	Operating Voltage (V_{LCD})	 <p>V_{LCD} : Operating Voltage F : Frame Frequency</p>
7.1.2	Viewing Angle	 <p>LEFT(θ_{x2}) RIGHT(θ_{x1}) FRONT (θ_{y1}) REAR (θ_{y2})</p>

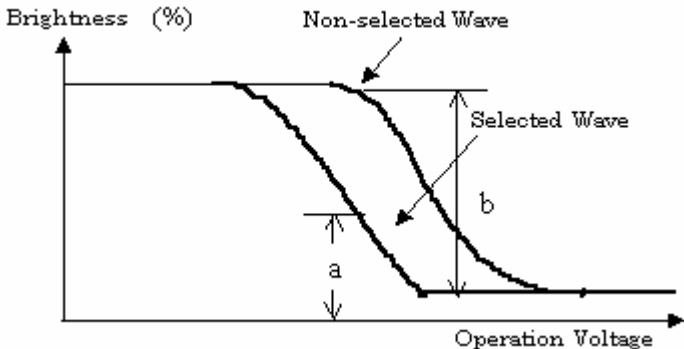
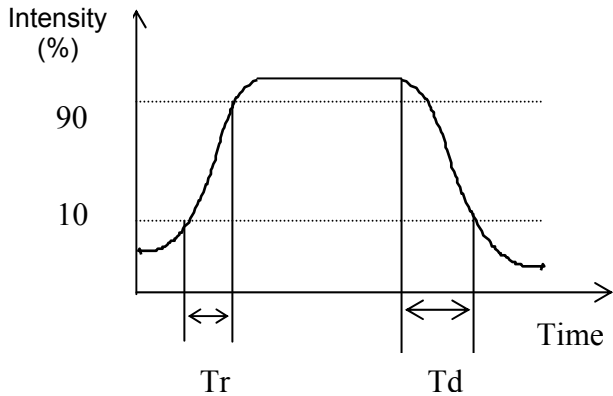

No.	Characteristics	Definition
7.1.3	Contrast Ratio <i>Conditions</i> (a) Operating Voltage: V_{LCD} (b) Temperature: 25°C (c) Viewing Angle, $\theta = 0^\circ$	 <p>Contrast Ratio = $\frac{\text{Brightness of non-selected state (b)}}{\text{Brightness of selected state (a)}}$</p>
7.1.4	Time response	 <p>Tr : Measured between 10% and 90% of LCD segment maximum response with V_{ON}.</p> <p>Td : With voltage switches to zero and the instant LCD segment reaches 10% of its maximum response.</p>



8.0 Interface

8.1	Display Controller	-
8.2	Display driver	SPLC086A
8.3	Cycle duty	1/240
8.4	Pin-out Assignments	
CONNECTOR (CNI)		
Pin No	Symbol	Function
1	XD0	Display data
2	XD1	
3	XD2	
4	XD3	
5	YDIS	Display off signal
6	YD	Frame Signal
7	WF	LCD drive output AC Signal
8	LP	Latch pulse for column driver. Shift clock for row driver. (Data latch)
9	XSCL	X-driver shift clock. (Data shift)
10	VDD	Supply terminal of module
11	VSS	Ground terminal of module
12	VEE	Negative supply for Liquid Crystal Drive
13	V0	Liquid Crystal Display contrast adjust
14	VBL(+)	Supply terminal of backlight



9.0 Timing Diagram For LCD Driver.

9.1 LCD Driver Timing Characteristics for SPLC086A

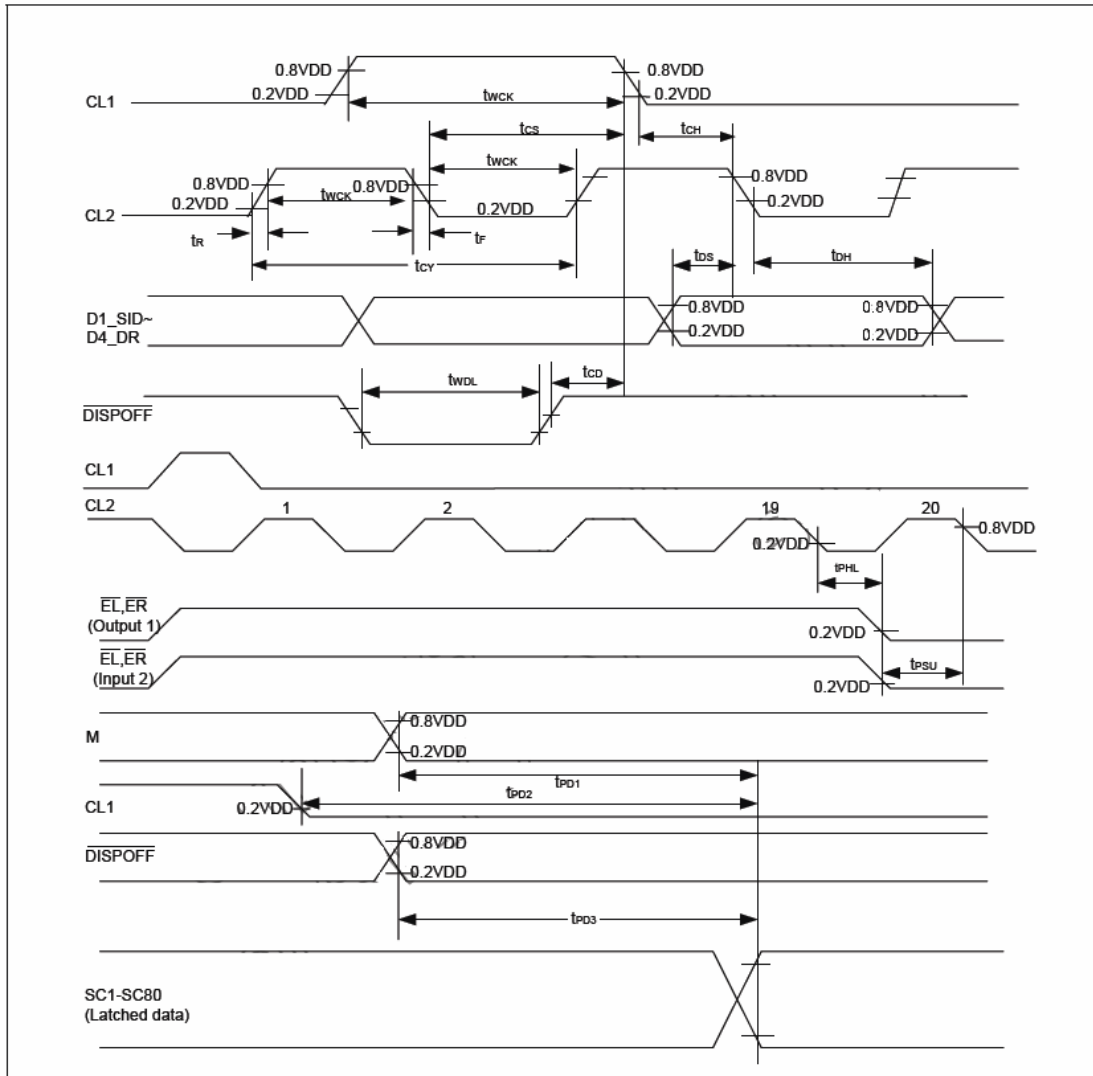

Timing Characteristic for Segment Mode



(VSS = 0V, T_A = - 30°C – +85°C)

Characteristic	Symbol	Test Condition	(1) VDD = 5.0V ±10%			(2) VDD = 3.0V ±10%			Unit
			Min.	Typ.	Max.	Min.	Typ.	Max.	
Clock cycle time	t _{CY}	Duty = 50%	125	-	-	250	-	-	ns
Clock pulse width	t _{WCK}	-	45	-	-	95	-	-	
Clock rise/fall time	t _{R/F}	-	-	-	-	-	-	30	
Data set-up time	t _{DS}	-	30	-	-	65	-	-	
Data hold time	t _{DH}	-	30	-	-	65	-	-	
Clock set-up time	t _{CS}	-	80	-	-	120	-	-	
Clock hold time	t _{CH}	-	80	-	-	120	-	-	
Propagation delay time	t _{PHL}	$\overline{\text{EL}}$ Output	-	-	60	-	-	125	
		$\overline{\text{ER}}$ Output	-	-	60	-	-	125	
$\overline{\text{EL}}$, $\overline{\text{ER}}$ set-up time	t _{PSU}	$\overline{\text{EL}}$ Input	30	-	-	65	-	-	
		$\overline{\text{ER}}$ Input	30	-	-	65	-	-	
$\overline{\text{DISPOFF}}$ low pulse width	t _{WDL}	-	1.2	-	-	1.2	-	-	μs
$\overline{\text{DISPOFF}}$ clear time	t _{CD}	-	100	-	-	100	-	-	ns
M – OUT propagation delay time	t _{PD1}	C _L = 15pF	-	-	1.0	-	-	1.2	μs
CL1 - OUT propagation delay time	t _{PD2}		-	-	1.0	-	-	1.2	
$\overline{\text{DISPOFF}}$ - OUT propagation delay time	t _{PD3}		-	-	1.0	-	-	-	

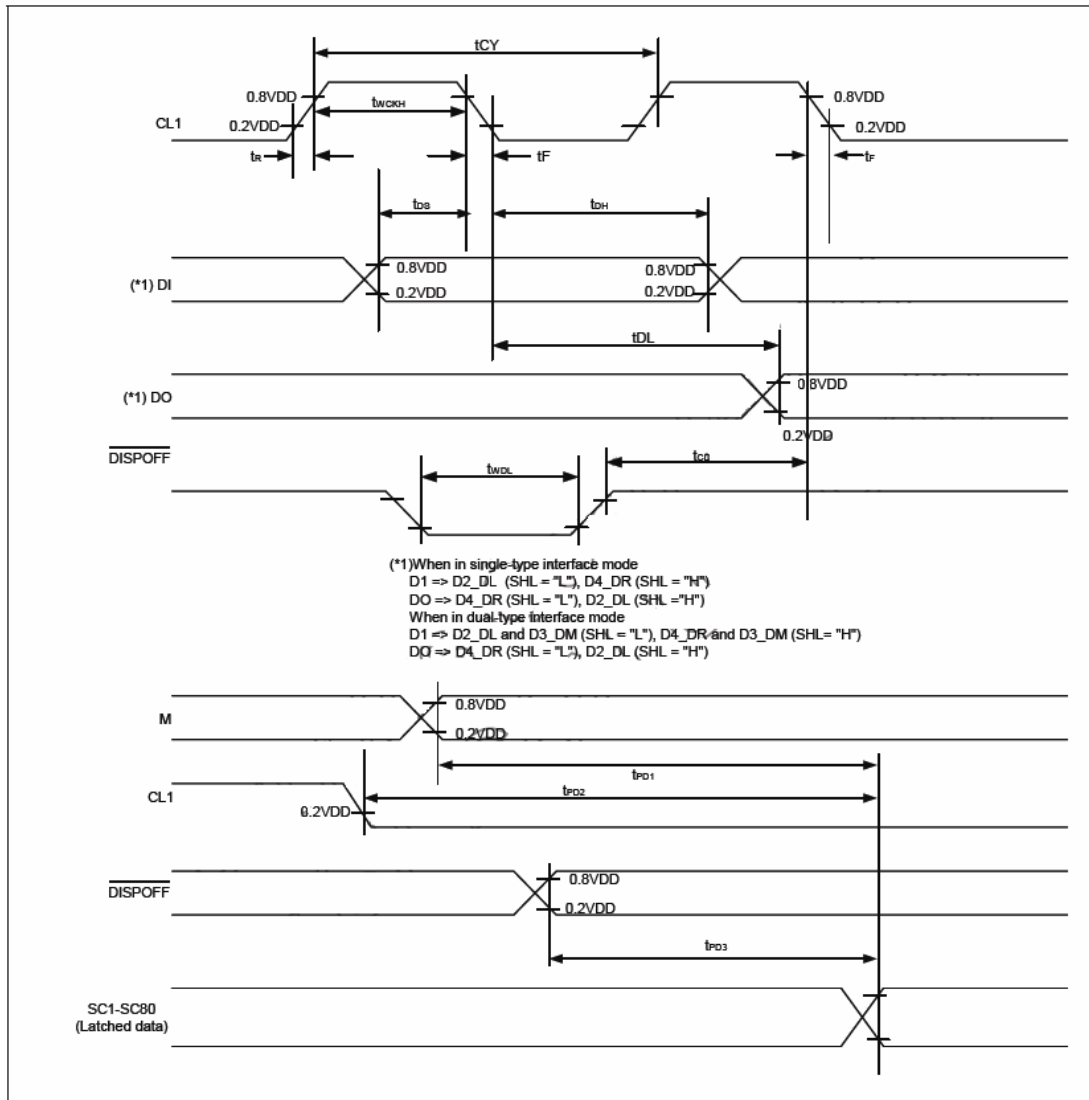

Timing Characteristic for Common Mode

(VSS = 0V, TA = - 30°C – +85°C)

Characteristic	Symbol	Test Condition	(1) VDD = 5.0V ±10%			(2) VDD = 3.0V ±10%			Unit
			Min.	Typ.	Max.	Min.	Typ.	Max.	
Clock cycle time	t _{CY}	Duty = 50%	250	-	-	500	-	-	ns
Clock pulse width	t _{WCKH}	-	45	-	-	95	-	-	
Clock rise / fall time	t _r /t _f	-	-	-	50	-	-	50	
Data set-up time	t _{DS}	-	30	-	-	65	-	-	
Data hold time	t _{DH}	-	30	-	-	65	-	-	
DISPOFF low pulse width	t _{WDL}	-	1.2	-	-	1.2	-	-	
DISPOFF clear time	t _{CD}	-	100	-	-	100	-	-	
Output delay time	t _{DL}	C _L = 15pF	-	-	200	-	-	250	ns
M - OUT propagation delay time	t _{PD1}		-	-	1.0	-	-	1.2	
CL1 - OUT propagation delay time	t _{PD2}		-	-	1.0	-	-	1.2	
DISPOFF - OUT propagation delay time	t _{PD3}		-	-	1.0	-	-	1.2	



10.0 Power Supply

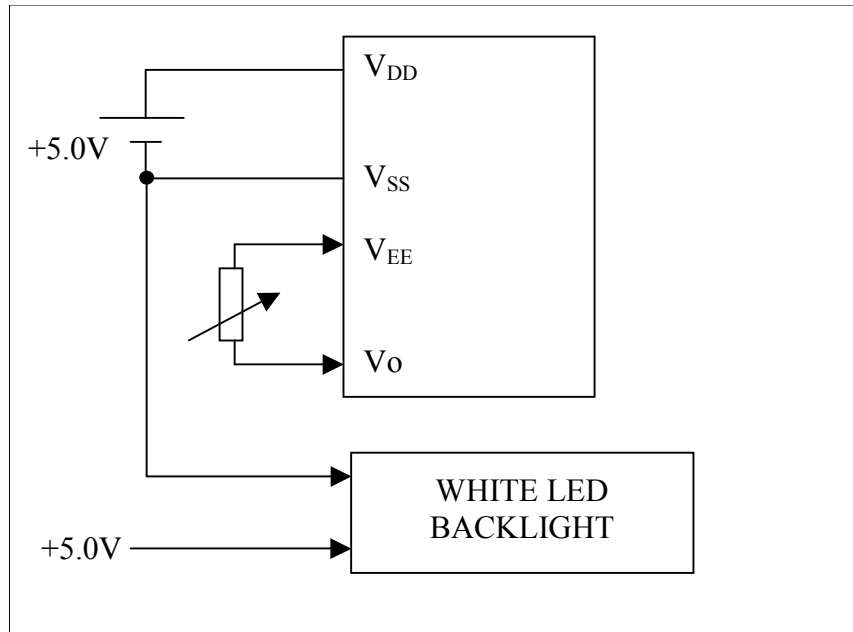

11.0 Block Diagram

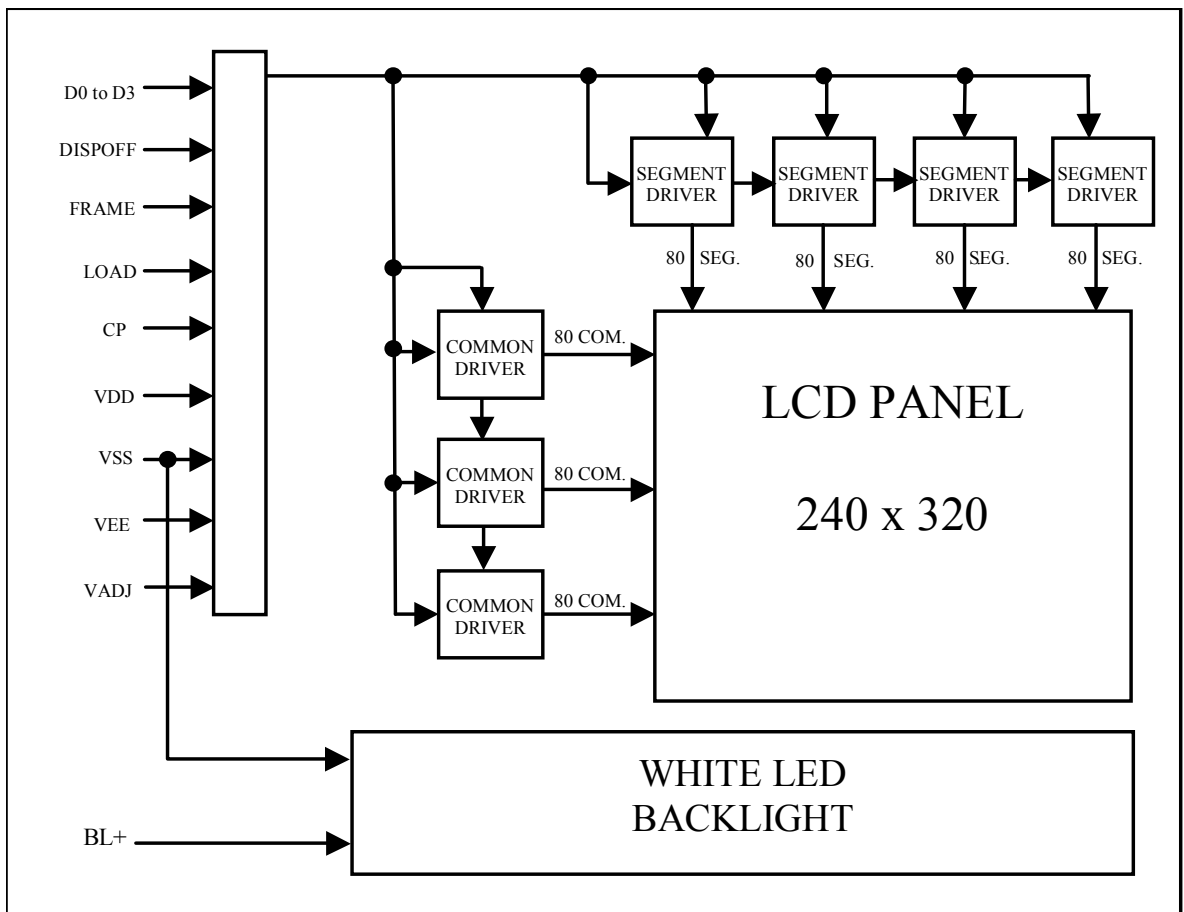



12.0 Quality assurance:

1. CRITERIA INVOLVED:

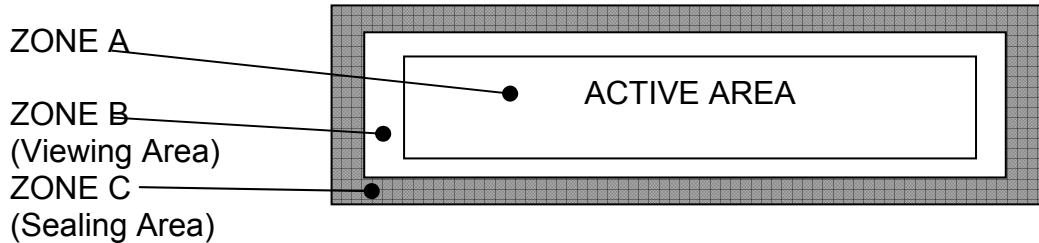

No.	ITEM
1.1	Black Spot, Foreign Materials, White Spot, Polarizer Damage

CRITERIA

Round Shape (solid figure)

Mean diameter = X (Long axis + short axis) /2	Maximum Acceptance Numbers		
	Zone A	Zone B	Zone C
$X \leq 0.10$	Disregard	Disregard	Disregard
$0.10 < X \leq 0.15$	3	3	
$0.15 < X \leq 0.25$	1	2	
$0.25 < X \leq 0.35$	1	1	
$X > 0.35$	0	0	

*The 1/3 or larger parts of individual dot has to be lighted on. The solid figure is that the defect has clear-cut outline at the optimum driving condition In both positive and negative, of which size does not change when the contrast changes.

Mean diameter = X (Long axis + short axis) /2	Maximum Acceptance Numbers		
	Zone A	Zone B	Zone C
$X \leq 0.60$	Disregard	Disregard	Disregard
$0.60 < X \leq 0.70$	3		
$0.70 < X \leq 0.80$	1		
$X > 0.80$	0		

* The faded figure means that the defects has unclear outline at the optimum driving condition in both positive and negative, of which size seems to change when the contrast changes.



3) Linear (Fibrous)

Size		Maximum Acceptable No.		
Length	Width	Zone A	Zone B	Zone C
Disregard	≤ 0.03mm	Disregard		Disregard
≤ 2mm	≤ 0.05mm	3		
≤ 1mm	≤ 0.10mm			
-----	> 0.10mm	Due to (1) round defect		

* Length is the whole length and width the maximum width of foreign material.

**Total amount of spotting defects including round and linear:-
5 are the totally permissible numbers of defects in Zone A & B including above (1), (2), (3). In case of the total permissible, the minimum distance has to be 5mm or larger between every couple of defects.**

APPENDIX II

<u>NO</u>	<u>ITEM</u>
1.2	Pin Hole

	<p>Maximum acceptance numbers: 1 per dot 3 per display area (active area)</p>
	<p>Maximum acceptance numbers: 1 per dot 3 per display area (active area)</p> <p><i>¾ or larger part of dot area has to be effective for display.</i></p>

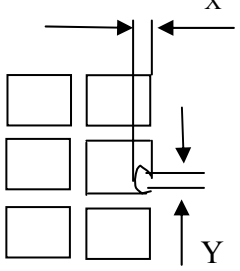
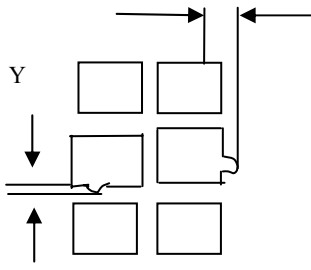

1.3 Deformed display dot

<p>1) Lacked deformation</p> 	<p>$0.15 \geq X$ $0.15 \geq Y$</p>
<p>2) Added deformation</p> 	<p>$0.02 > X$ $0.02 > Y$</p>

1.4 Polarizer Air Bubbles

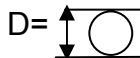

Size	Maximum Acceptable No.		
	Zone A	Zone B	Zone C
$D \leq 0.30\text{mm}$	Disregard	Disregard	Disregard if the polarizer not lifted up pealed off
$D \leq 0.50\text{mm}$	2		
$0.50 < D \leq 0.60\text{mm}$	1	2	
$D > 0.60\text{mm}$	0		
Total amount of bubbles	3 are the totally permissible numbers of bubble		

REMARK

All the other items of inspection that are not included herein must be determined by the "Limit Standard" sample, which were occasionally set up with the mutual consent of both parties. In every case of the items set up with the Limit Standard, the Limit Standard always takes precedence over the other means of definition.



14. Precaution for using LCM

1. Liquid Crystal Display (LCD)

LCD is made up of glass, organic sealant, organic fluid and polymer based polarizers. The following precautions should be taken when handling.

- b) Keep the temperature within the range of use and storage. Excessive temperature and humidity could cause polarization degradation, polarizer peel off or bubble.
- c) Do not contact the exposed polarizer with anything harder than HB pencil lead. To clean dust off the display surface, wipe gently with cotton, chamois or other soft material soaked in petroleum benzine.
- d) Wipe off saliva or water drops immediately. Contact with water over a long period of time may cause polarizer deformation or colour fading, while an active LCD with water condensation on its surface will cause corrosion of ITO electrodes.
- e) Glass can be easily chipped or cracked from rough handling, especially at corners and edges.
- f) Do not drive LCD with DC voltage.

2. Liquid Crystal Display Modules.

2.1 Mechanical Considerations

LCM are assembled and adjusted with a high degree of precision. Avoid excessive shocks and do not make any alterations or modification. The following should be noted.

- a) Do not tamper in any way with the tabs on the metal frame.
- b) Do not modify the PCB by drilling extra holes, changing its outline, moving its component or modifying its pattern.
- c) Do not touch the elastomer connector, especially insert a backlight panel (for example, EL)
- d) When mounting a LCM make sure that the PCB is not under any stress such as bending or twisting. Elastomer contacts are very delicate and missing pixels could result from slight dislocation of any of the elements.

- a) Avoid pressing on the metal bezel, otherwise the elastomer connector could be deformed and lose contact, resulting in missing pixels.

2.2 Static Electricity

LCM contains CMOS LSI's and the same precaution for such devices should apply, namely

- a) The operator should be grounded whenever he/she comes into contact with the module. Never touch any of the conductive parts such as the LSI pads, the copper leads on the PCB and the interface terminals with any parts of the human body.
- b) The modules should be kept in antistatic bags or other containers to static for storage.
- c) Only properly grounded soldering irons should be used.
- d) If an electric screwdriver is used, it should be well grounded and shielded from commutator spark.
- e) The normal static prevention measures should be observed for work clothes and working benches, the latter conductive (rubber) mat is recommended.
- f) Since dry air is inductive to statics, a relative humidity of 50-60% is recommended.

2.3 Soldering

- a) Solder only to the I/O terminals.
- b) Use only soldering irons with proper grounding and no leakage.
- c) Soldering temperature: 280°C
- d) Soldering time: 3 to 4 sec
- e) Use eutectic solder with resin flux fill.
- f) If flux is used, the LCD surface should be covered to avoid flux spatters. Flux residue should be removed afterwards.



2.4 Operation

- a) The contrast can be adjusted by varying the LCD driving voltage V_0
- b) Driving voltage should be kept within specified range, excess voltage shortens display life.
- c) Response time increases with decrease in temperature.
- d) Display may turn black or dark blue at temperature above its operational range, this is (however not pressing on the viewing area) may cause the segments to appear “fractured”.
- e) Mechanical disturbance during operation (such as pressing on the viewing area) may cause the segments to appear “fractured”.

2.5 Storage

If any fluid leaks out of the damaged glass cell, wash off any human part that comes into contact with soap and water. Never swallow the fluid. The toxicity is extremely low but caution should be exercised at all the time.

2.6 Limited Warranty

Unless otherwise agreed between Crystal Clear Technology and customer, Crystal Clear Technology will replace or repair any of its LCD and LCM which is found to be defective electrically and visually when inspected in accordance with Crystal Clear Technology acceptance standards, for a period of one year from date of shipment. Confirmation of such date shall be based on freight documents. The warranty liability of Crystal Clear Technology is limited to repair and/or replacement on the terms set forth above. Crystal Clear Technology will not be responsible for any subsequent or consequential events.

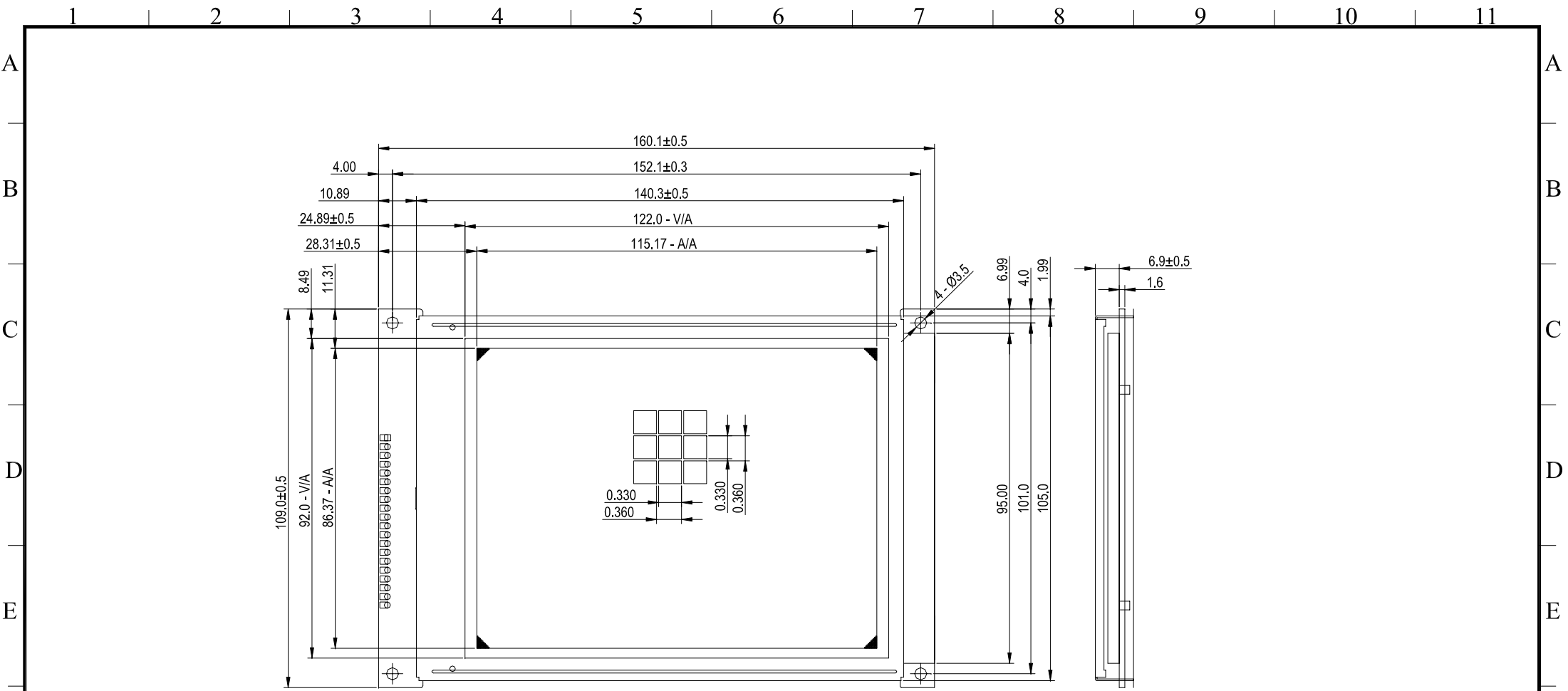

- NOTE :
1. DISPLAY : STN, NEGATIVE BLUE, 6 O'CLOCK, 1/240 DUTY, 1/17 BIAS.
 2. POWER SUPPLY : 5.0V,
 3. Topr : -20°C TO +70°C
 4. Tstg : -30°C TO +80°C
 5. SYMBOL (⊕) INDICATE CRITICAL DIMENSION OR SPECIAL SPECIFICATION
 6. SYMBOL (∅) INDICATE REPEATED OR REFERENCE DIMENSION
 7. PACKING - USE BUBBLE BAG

PIN OUT

1	2	3	4	5	6	7	8	9	10	11	12	13	14
XD0	XD1	XD2	XD3	YDIS	YD	WF	LP	XSC1	VDD	VSS	VEE	V0	BL(+)

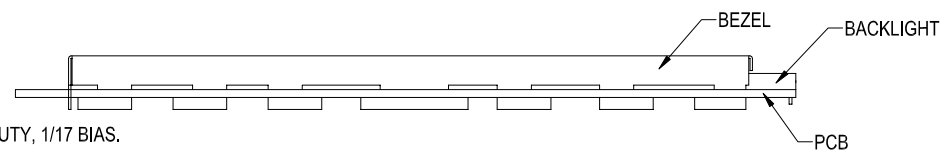

MODEL NAME	1	MATERIAL	REMARKS
------------	---	----------	---------

	CRYSTAL CLEAR TECHNOLOGY SDN BHD 16, JLN TP5, TMN PERINDUSTRIAN SIME UEP, 47600 SUBANG JAYA, SELANGOR DARUL EHSAN.		PART NAME <h2 style="margin: 0;">ASSEMBLY DRAWING</h2>		
	APPROVED	CHECKED	DRAWN KHAIRIAH 06-02-2007	 UNIT : MM	DRAWING NUMBER G2432W32SBN10
				SHEET 1 / 1	REV. 1