



LUXGUARD[™]

CM1771

High voltage ESD protection

Aug 2009



Topics

- Introduction & Target markets
- Features and Benefit
- Specifications
- Pricing and Availability



CM1771 – an introduction

- Industry's first High-voltage ESD protection device
- High level of ESD protection even at 100v
- Back-to-Back configuration with symmetric protection
- Illumination (indoor and outdoor), Street Lighting and protect multi – string LED lamp module (1-30 LEDs in a string)
- Small die size



CM1771 – Features vs Benefits

- Industry's first 100v BV part
- HBM ESD protection at 6KV
- Back-to-Back configuration
- Used in multiple end applications
- Small die size
- Single ESD protector protecting a string (1-30) LEDs
- High level of ESD protection at a High breakdown voltage
- Symmetric protection
- Automotive, illumination (indoor and outdoor)
- Fit into existing lamp architectures



CM1771

- High voltage ESD protection



Product specifications

Electrical Schematic

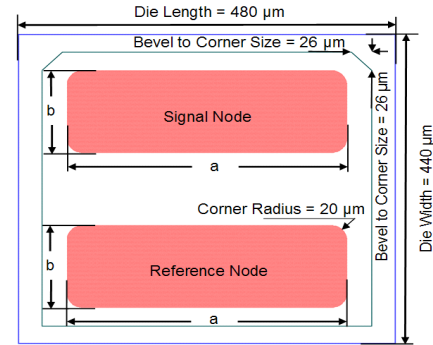
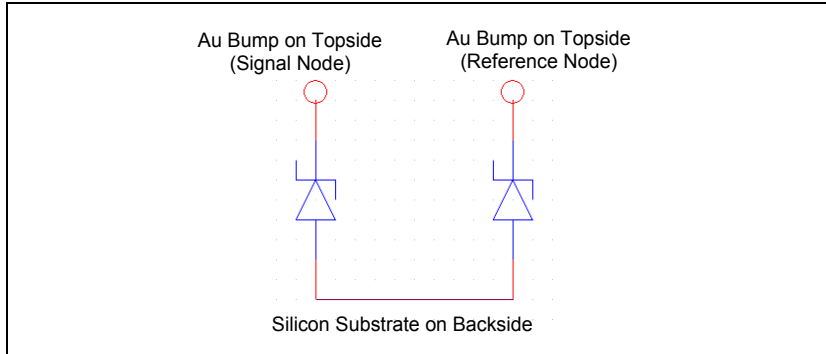

Mechanical Details

ELECTRICAL OPERATING CHARACTERISTICS				
Electrical Specifications	Min.	Typ.	Max.	Unit
Leakage Current at +85V at +25°C			1	μA
V_{BD} = Breakdown Voltage on Signal Node (Note 1) at 1.0mA, +25°C	90	100	110	V
at -1.0mA, +25°C	-80		-60	V
V_{ESD} = Channel Clamp Voltage at -4kV HBM (Note 1): Transmission Line Pulse Test at 25°C	-160			V
V_{PV} = ESD Voltage Rating (Note 1, Note 2): per IEC 61000-4-2	±3			kV

Note 1: This parameter is guaranteed by design and characterization.

Note 2: Per the standard, 3 positive and 3 negative strikes are applied, one second apart.

MECHANICAL SPECIFICATIONS (NOTE 1)		
Parameter	Condition	Unit
Composition	Silicon wafer, P+ doped.	
Die Shape	Rectangle	
Die Length	480 ± 10	μm
Die Width	440 ± 10	μm
Thickness	6	Mil
Top Pad Length (a)	356	μm
Top Pad Width (b)	117	μm
Top Pads Spacing (d)	103	μm
Top Pad Composition	Au (Gold)	
Top Pad Thickness	3	μm
Back Metal (backside)	No back metal (Silicon substrate)	

Note 1: Dimensions are typical values if tolerances are not specified.



Availability

- Samples : October 2009
- Production: Q1, 2010
- For more information, please register at http://www.cmd.com/contact_us/email/luxguard/