



LuxGuard™ Product Introduction

Q1 CY2009



LuxGuard™ Overview

LED protection

Target HB and UHB LED markets

Best in Class ESD protection and
Thermal management

First product in 2001

Wide range of solutions

Shipped over 300 million units

Leverage of extensive application
knowledge to design unique
differentiated solutions

The LuxGuard logo features the word 'LUXGUARD' in a bold, yellow, sans-serif font. A blue swoosh underline is positioned above the 'L' and 'U'.



HB / UHB LED Market TAM

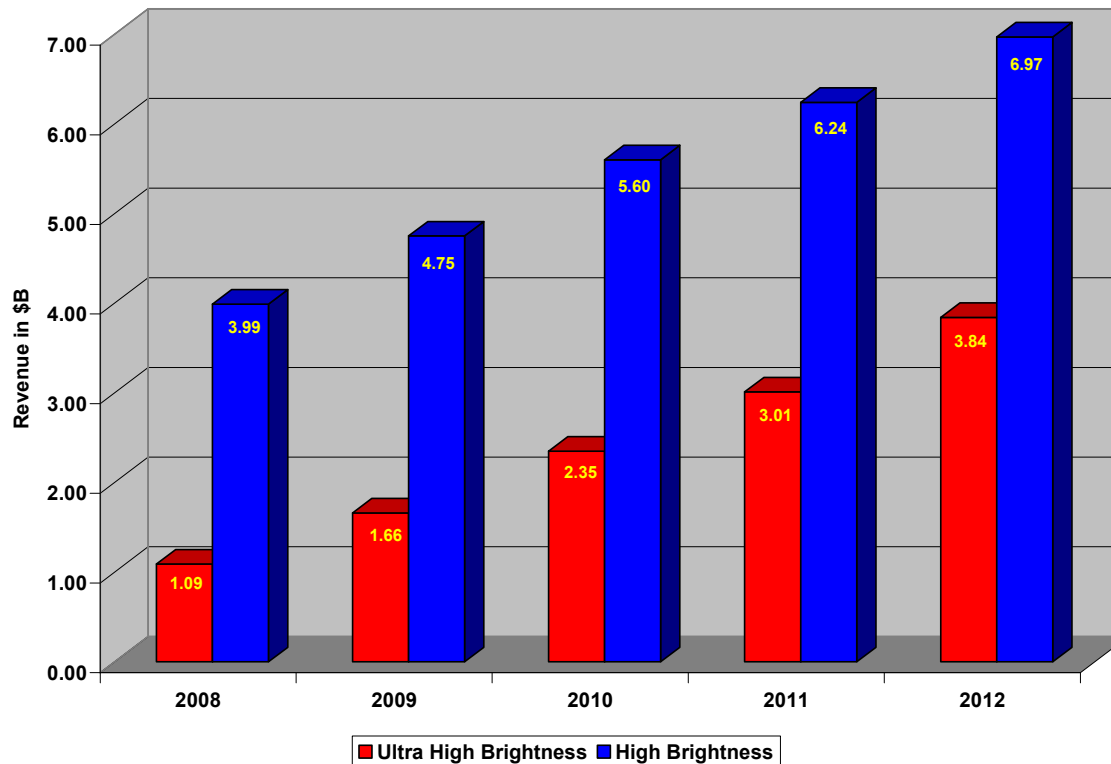

Source: LED market tracker, iSuppli, Sep'07



LuxGuard™ Benefits

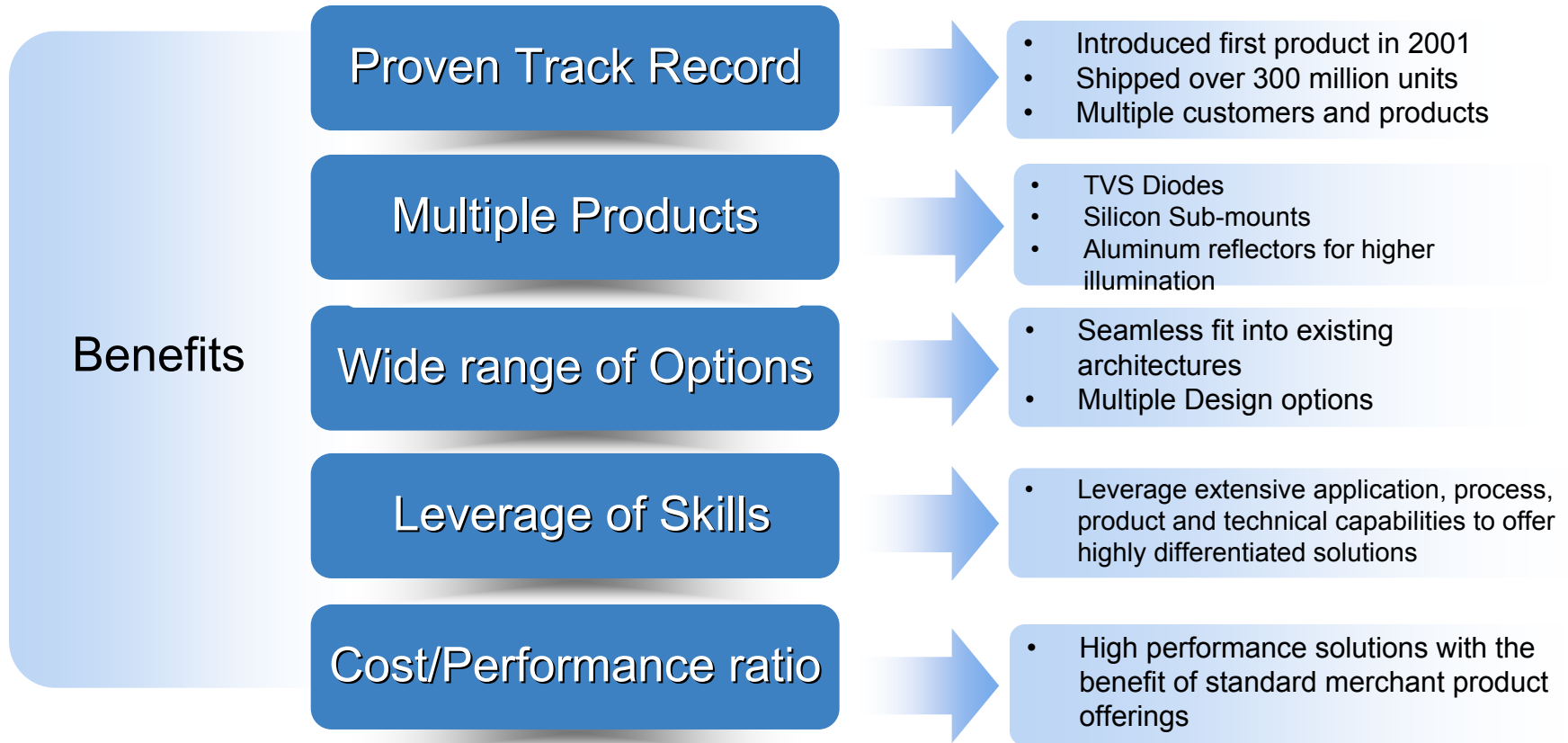



LuxGuard™ Products for LED Manufacturers

- TVS diodes for ESD protection of the LEDs
- Silicon submount for minimizing thermal mismatch of LED on copper lead-frames
- Aluminum reflectors for higher illumination
- WLCSP ball drop for Flip Chip application and elimination of wire bonds



Product Options

- Topside Options
 - Aluminum Pad
 - Copper Pad
 - Other options also available
- Backside Metal Options
 - Au (Silver Epoxy to leadframe)
 - Other options available
- Multi-LED submounts and sidemounts
- Standard submount thickness
 - *10 mils ±1 mil*
- Thinner submounts are available



LuxGuard™ Value Proposition

- Volume Supplier of ESD solutions for LED Applications
 - ESD protection is a focus and core competence for CMD
 - Complete manufacturing capabilities
 - High volume, high quality supplier
 - Proven track record
- Wide range of solutions
 - Single LED or string of LEDs
 - Support horizontal and vertical LEDs
 - ESD die or ESD submounts
- Tailored solutions support customer innovations
- Leverage extensive application, manufacturing and technical capabilities to offer highly differentiated solutions with the same benefits enjoyed by merchant solutions



LED Structures

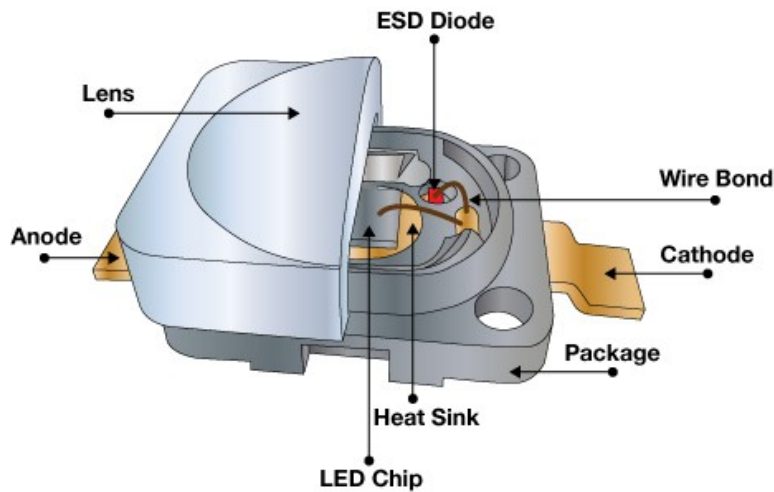

Sidemount

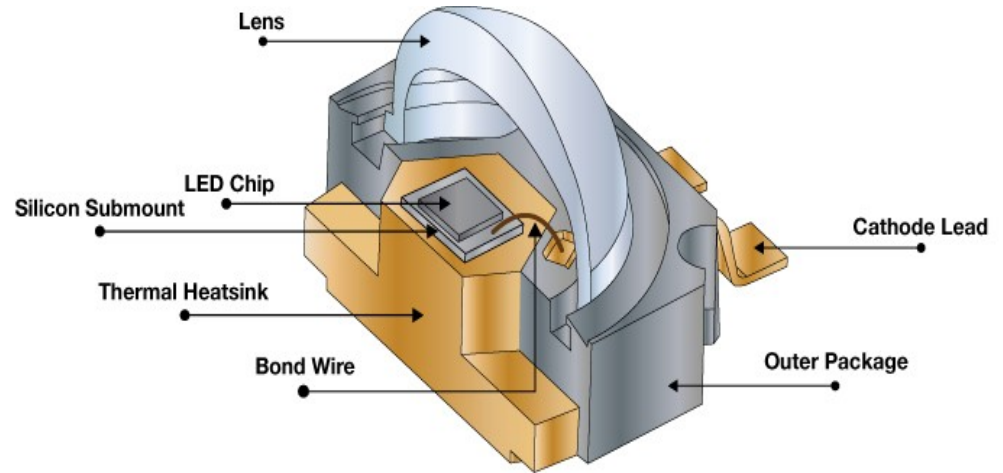

Submount



Summary

- Best in class ESD protection and Thermal Management solutions for the LED market
- Fully customizable product to fit into existing architectures
- Wide range of solutions with multiple options
- Over 300 Million units shipped
- Leverage of extensive application, manufacturing and technical knowledge to enable a highly differentiated solution



Availability

- Samples : Now
- Production : Now
- For more information, please register at http://www.cmd.com/contact_us/email/luxguard/