



Specification

G070Y2-L01

Version October 2009

Note: This specification is subject to change without prior notice

- CONTENTS -

REVISION HISTORY	-----	3
1. GENERAL DESCRIPTION	-----	4
1.1 OVERVIEW		
1.2 FEATURES		
1.3 APPLICATION		
1.4 GENERAL SPECIFICATIONS		
1.5 MECHANICAL SPECIFICATIONS		
2. ABSOLUTE MAXIMUM RATINGS	-----	6
2.1 ABSOLUTE RATINGS OF ENVIRONMENT		
2.2 ELECTRICAL ABSOLUTE RATINGS		
2.2.1 TFT LCD MODULE		
2.2.2 LED CONVERTER		
3. ELECTRICAL CHARACTERISTICS	-----	8
3.1 RECOMMENDED OPERATING CONDITION		
3.2 BACKLIGHT UNIT		
4. BLOCK DIAGRAM	-----	11
4.1 TFT LCD MODULE		
5. INPUT TERMINAL PIN ASSIGNMENT	-----	12
5.1 LVDS I/O PIN ASSIGNMENT		
5.2 BACKLIGHT PIN ASSIGNMENT		
5.3 SCANNING DIRECTION		
5.4 COLOR DATA INPUT ASSIGNMENT		
6. INTERFACE TIMING	-----	16
6.1 TIMING CHARACTERISTICS		
6.2 LVDS INPUT DATA FORMAT		
6.3 POWER ON/OFF SEQUENCE		
7. OPTICAL CHARACTERISTICS	-----	19
7.1 TEST CONDITIONS		
7.2 OPTICAL SPECIFICATIONS		
8. RELIABILITY TEST	-----	22
8.1 RELIABILITY TEST CONDITION		
9. PACKAGING	-----	23
10. DEFINITION OF LABELS	-----	25
11. PRECAUTIONS	-----	26
12. MECHANICAL CHARACTERISTICS	-----	27

REVISION HISTORY

Version	Date	Section	Description
Ver 2.0	Oct. 30, '09	All	G070Y2-L01 Approval specification was first issued.

1. GENERAL DESCRIPTION

1.1 OVERVIEW

G070Y2-L01 is a 7inch TFT Liquid Crystal Display module with a LED backlight unit and a-20pin 6/8bit LVDS interface controller board. The converter for the LED Backlight Unit is built in. This module supports 800 (R.G.B)x 480 WVGA mode which main application is the automotive display and industrial field.

1.2 FEATURES

- Wide viewing angle.
- Fast response time
- Wide operating temperature
- Reversible scan function
- 6/8 bit convertible
- High Color gamut (NTSC : 72%)

1.3 APPLICATION

- Automotive Display
- Industry Application

1.4 GENERAL SPECIFICATIONS

Item	Specification	Unit	Note
Diagonal Size	7	inch	
Active Area	152.4x91.44	mm	(1)
Bezel Opening Area	154.6x93.64	mm	
Driver Element	a-si TFT active matrix	-	-
Pixel Number	800 x R.G.B. x 480	pixel	-
Pixel Pitch	0.1905 x 0.1905	mm	-
Pixel Arrangement	RGB vertical stripe	-	(2)
Display Colors	262k or 16.2M	color	-
Display Mode	Normal White	-	-
Surface Treatment	Anti-glare, Hard Coating (3H)	-	-
Module Power Consumption	3.56	W	Typ.

Note (1) Please refer to the attached drawings for more information of front and back outline dimensions.

Note (2)

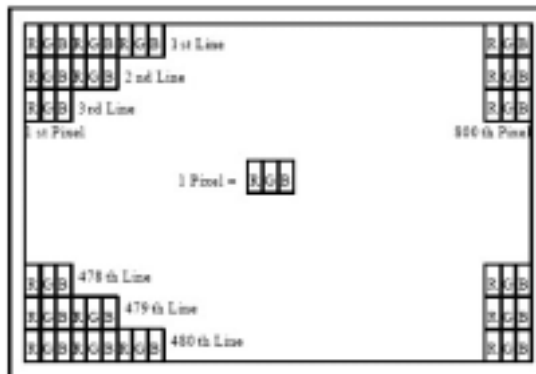

1.5 MECHANICAL SPECIFICATIONS

Item		Min.	Typ.	Max.	Unit	Note
Module Size	Horizontal (H)	164.3	165	165.3	mm	(1)
	Vertical (V)	103.3	104	104.3	mm	
	Depth (D)	9.03	9.53	10.03	mm	
Weight			147	162	g	

Note (1) Please refer to the attached drawings for more information of front and back outline dimensions.

2. ABSOLUTE MAXIMUM RATINGS

2.1 ABSOLUTE RATINGS OF ENVIRONMENT

Item	Symbol	Value		Unit	Note
		Min.	Max.		
Operating Ambient Temperature	T _{OP}	-30	+85	°C	
Storage Temperature	T _{ST}	-40	+95	°C	

Note (1) Temperature and relative humidity range is shown in the figure below.

(2) Wet-bulb temperature should be 39 °C Max. (Ta > 40 °C).

(3) No condensation.

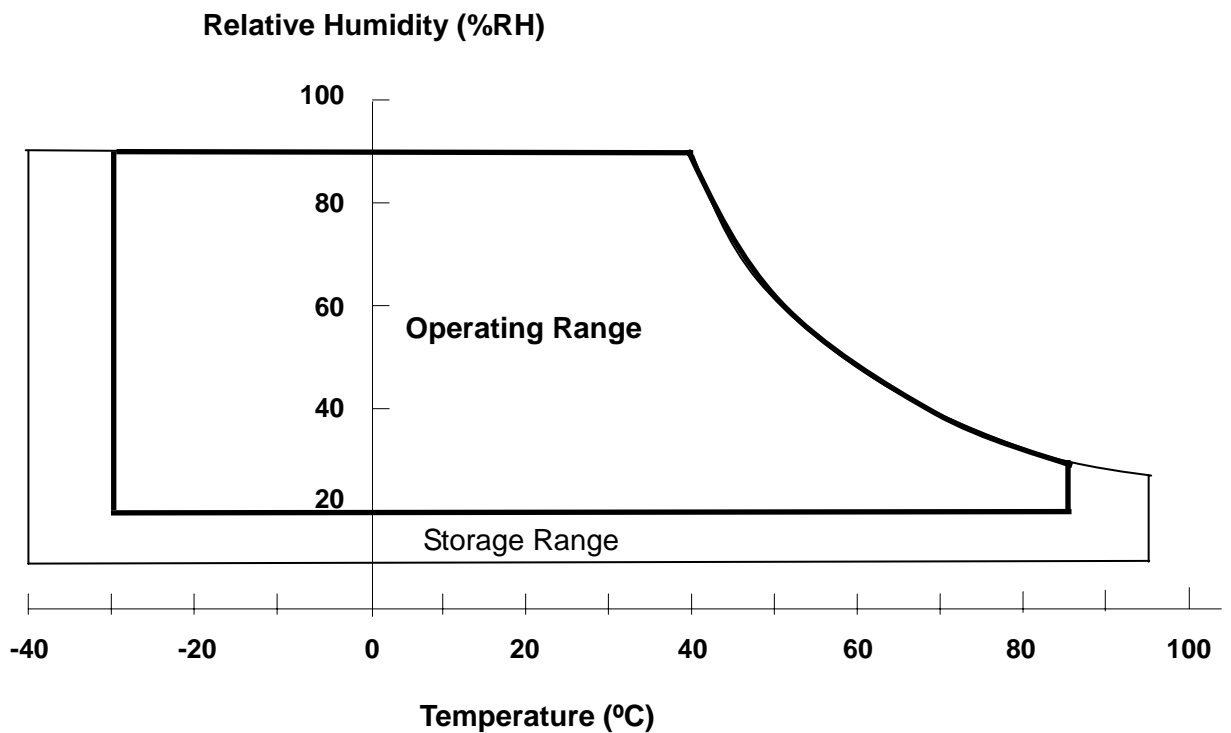

2.2 ELECTRICAL ABSOLUTE RATINGS

2.2.1 TFT LCD MODULE

 $T_a = 25 \pm 2 \text{ }^\circ\text{C}$

Item	Symbol	Value		Unit	Note
		Min.	Max.		
Power Supply Voltage	Vcc	-0.3	4	V	(1)

2.2.2 LED CONVERTER

Item	Symbol	Value		Unit	Note
		Min.	Max.		
Converter Voltage	V_i	-0.3	18	V	(1), (2)
Enable Voltage	EN	---	4	V	
Backlight Adjust	ADJ	---	3.3	V	

Note (1) Permanent damage to the device may occur if maximum values are exceeded. Function operation should be restricted to the conditions described under Normal Operating Conditions.

Note (2) Specified values are for LED converter (Refer to 3.2 for further information).

3. ELECTRICAL CHARACTERISTICS

3.1 RECOMMENDED OPERATION CONDITION

Ta = 25 ± 2 °C

Parameter	Symbol	Value			Unit	Note
		Min.	Typ.	Max.		
Power Supply Voltage	V _{CC}	3.0	3.3	3.6	V	(1)
Rush Current	I _{RUSH}			1.5	A	(2)
Power Supply Current	White		140		mA	(3)a
	Black		170		mA	(3)b
LVDS Differential Input High Threshold	V _{TH(LVDS)}			100	mV	-
LVDS Differential Input Low Threshold	V _{TL(LVDS)}	-100			mV	-
LVDS Common Mode Voltage	V _{CM}		1.2		V	-

Note (1) The assembly should be always operated within above ranges.

Note (2) Measurement Conditions:

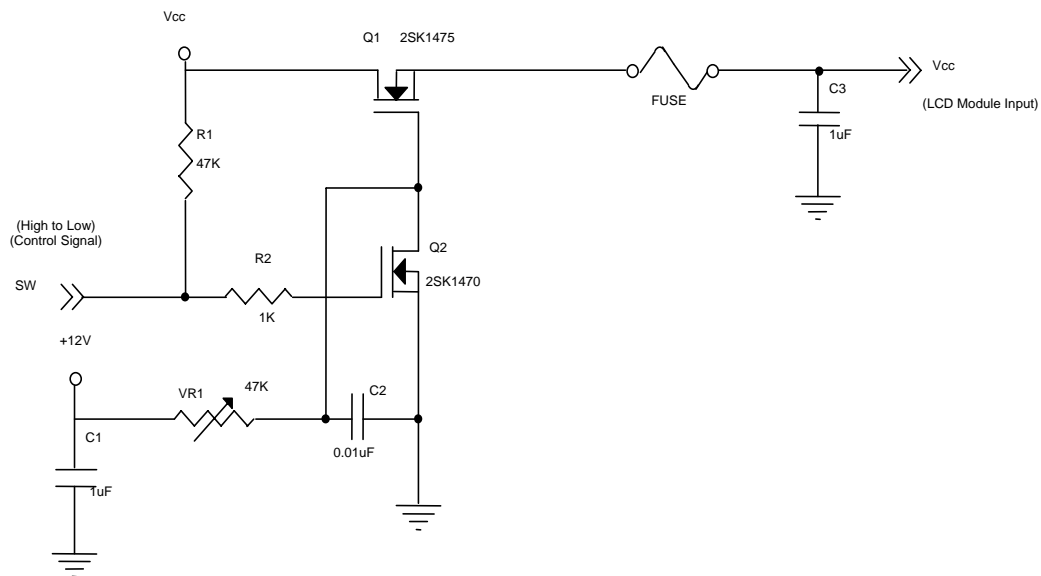

Vcc rising time is 470µs

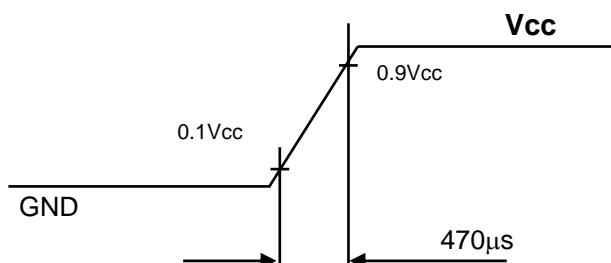

Note (3) The specified power supply current is under the conditions at $V_{cc} = 3.3V$, $T_a = 25 \pm 2 \text{ }^\circ\text{C}$, $f_v = 60$ Hz, whereas a power dissipation check pattern below is displayed.

a. White Pattern

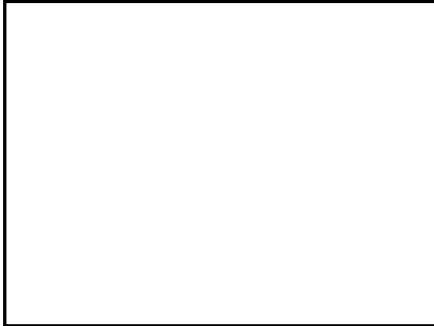

Active Area

b. Black Pattern

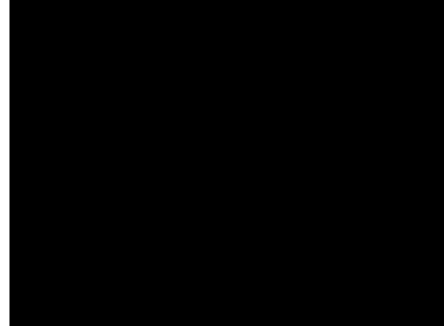

Active Area

3.2 BACKLIGHT UNIT

 $T_a = 25 \pm 2 \text{ }^\circ\text{C}$

Parameter	Symbol	Value			Unit	Note
		Min.	Typ.	Max.		
Converter Power Supply Voltage	V_i	10.8	12.0	13.2	V	
Converter Power Supply Current	I_i	---	0.25	---	A	@ $V_i = 12\text{V}$ (Duty 100%)
Converter Power Consumption	P_{LED}	---	3	---	W	@ $V_i = 12\text{V}$ (Duty 100%)
EN Control Level	Backlight on	2.0	---	3.3	V	
	Backlight off	0	---	0.8	V	
PWM Control Level	PWM High Level	2.0	---	3.3	V	
	PWM Low Level	0	---	0.15	V	
PWM Control Duty Ratio		20		100	%	
PWM Control Frequency	f_{PWM}	190	200	210	Hz	
LED Life Time	L_L	50,000			Hrs	(2)

Note (1) LED current is measured by utilizing a high frequency current meter as shown below:

Note (2) The lifetime of LED is defined as the time when it continues to operate under the conditions at $T_a = 25 \pm 2$ and $I_{LED} = 60\text{mA}_{DC}$ (LED forward current) until the brightness becomes 50% of its original value.

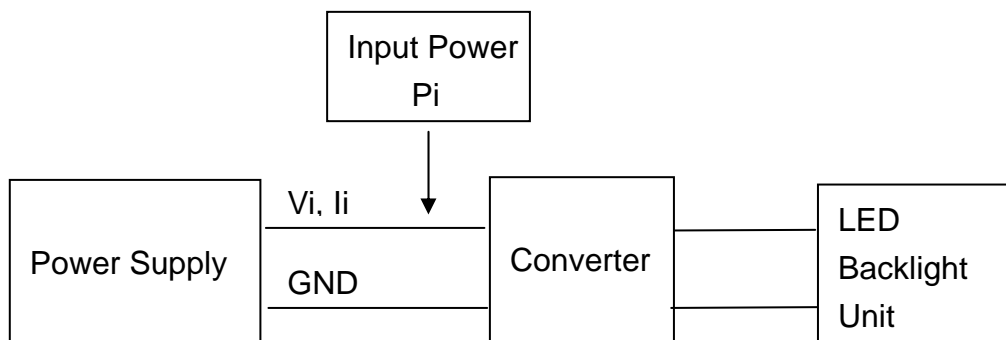

4. BLOCK DIAGRAM

4.1 TFT LCD MODULE

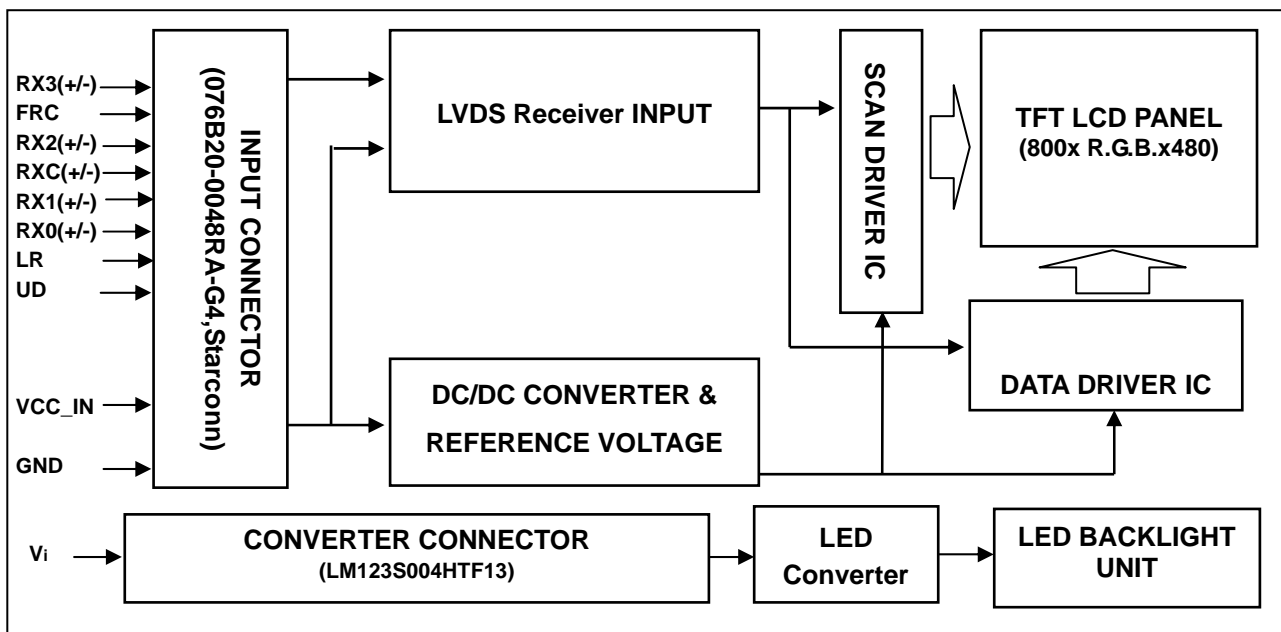

5. INPUT TERMINAL PIN ASSIGNMENT

5.1 LVDS I/O PIN ASSIGNMENT

Pin	Name	I/O	Description
1	RX3+	I	LVDS differential data input Pair 3.
2	RX3-	I	
3	NC	I	No Connected
4	FRC	I	Dithering control setting When FRC=H, the width of data input 8 bits When FRC=L, the width of data input 6 bits and set Dx0 and Dx1 to logical low (Default pull low)
5	GND	I	Ground
6	RXC+	I	LVDS differential Clock input Pair
7	RXC-	I	
8	GND	I	Ground
9	RX2+	I	LVDS differential data input Pair 2
10	RX2-	I	
11	GND	I	Ground
12	RX1+	I	LVDS differential data input Pair 1
13	RX1-	I	
14	GND	I	Ground
15	RX0+	I	LVDS differential data input Pair 0
16	RX0-	I	
17	LR	I	Shift direction of Source Driver IC internal shift register is controlled by this pin as show below: LR=H SO1→SO1200 (Default pull high) LR=L SO1200→SO1
18	UD	I	Gate Driver Up/down scan setting When UD=H, reverse scan When UD=L, normal scan (Default pull low)
19	VCC_IN	I	Digital power supply (+3.3V)
20	VCC_IN	I	Digital power supply (+3.3V)

Note (1) User's connector Part No.: 076B20-0048RA-G4, Starconn or equivalent

5.2 BACKLIGHT PIN ASSIGNMENT (Converter connector pin)

No	Symbol	I/O	Description
1	Vi	I	Converter input voltage
2	ADJ	I	Backlight Adjust
3	EN	I	Enable pin
4	V _{GND}		Converter ground

Note (1) User's connector Part No: LM123S004HTF13,4 PIN, UNE

5.3 SCANNING DIRECTION

The following figures show the image see from the front view. The arrow indicates the direction of scan.

Fig.1 Normal Scan



Fig.2 Reverse Scan



Fig.3 Reverse Scan



Fig.4 Reverse Scan



Fig. 1 Normal scan (pin 17, LR = High ; pin 18, UD = Low)

Fig. 2 Reverse scan (pin 17, LR = Low ; pin 18, UD = Low)

Fig. 3 Reverse scan (pin 17, LR = High ; pin 18, UD = High)

Fig. 4 Reverse scan (pin 17, LR = Low ; pin 18, UD = High)

5.4 COLOR DATA INPUT ASSIGNMENT

The brightness of each primary color (red, green and blue) is based on the 6-bit gray scale data input for the color. The higher the binary input, the brighter the color. The table below provides the assignment of color versus data input. (0: Low Level Voltage, 1: High Level Voltage)

Color		Data Signal																	
		Red						Green						Blue					
		R5	R4	R3	R2	R1	R0	G5	G4	G3	G2	G1	G0	B5	B4	B3	B2	B1	B0
Basic Colors	Black	0	0	0	0	0	0	0	0	0	0	0	0	0	0	0	0	0	0
	Red	1	1	1	1	1	1	0	0	0	0	0	0	0	0	0	0	0	0
	Green	0	0	0	0	0	0	1	1	1	1	1	1	0	0	0	0	0	0
	Blue	0	0	0	0	0	0	0	0	0	0	0	0	1	1	1	1	1	1
	Cyan	0	0	0	0	0	0	1	1	1	1	1	1	1	1	1	1	1	1
	Magenta	1	1	1	1	1	1	0	0	0	0	0	0	1	1	1	1	1	1
	Yellow	1	1	1	1	1	1	1	1	1	1	1	1	0	0	0	0	0	0
	White	1	1	1	1	1	1	1	1	1	1	1	1	1	1	1	1	1	1
Gray Scale Of Red	Red(0) / Dark	0	0	0	0	0	0	0	0	0	0	0	0	0	0	0	0	0	0
	Red(1)	0	0	0	0	0	1	0	0	0	0	0	0	0	0	0	0	0	0
	Red(2)	0	0	0	0	1	0	0	0	0	0	0	0	0	0	0	0	0	0
	⋮	⋮	⋮	⋮	⋮	⋮	⋮	⋮	⋮	⋮	⋮	⋮	⋮	⋮	⋮	⋮	⋮	⋮	⋮
	⋮	⋮	⋮	⋮	⋮	⋮	⋮	⋮	⋮	⋮	⋮	⋮	⋮	⋮	⋮	⋮	⋮	⋮	⋮
	Red(61)	1	1	1	1	0	1	0	0	0	0	0	0	0	0	0	0	0	0
	Red(62)	1	1	1	1	1	0	0	0	0	0	0	0	0	0	0	0	0	0
	Red(63)	1	1	1	1	1	1	0	0	0	0	0	0	0	0	0	0	0	0
Gray Scale Of Green	Green(0) / Dark	0	0	0	0	0	0	0	0	0	0	0	0	0	0	0	0	0	0
	Green(1)	0	0	0	0	0	0	0	0	0	0	1	0	0	0	0	0	0	0
	Green(2)	0	0	0	0	0	0	0	0	0	0	1	0	0	0	0	0	0	0
	⋮	⋮	⋮	⋮	⋮	⋮	⋮	⋮	⋮	⋮	⋮	⋮	⋮	⋮	⋮	⋮	⋮	⋮	⋮
	⋮	⋮	⋮	⋮	⋮	⋮	⋮	⋮	⋮	⋮	⋮	⋮	⋮	⋮	⋮	⋮	⋮	⋮	⋮
	Green(61)	0	0	0	0	0	0	1	1	1	1	0	1	0	0	0	0	0	0
	Green(62)	0	0	0	0	0	0	1	1	1	1	1	0	0	0	0	0	0	0
	Green(63)	0	0	0	0	0	0	1	1	1	1	1	1	0	0	0	0	0	0
Gray Scale Of Blue	Blue(0) / Dark	0	0	0	0	0	0	0	0	0	0	0	0	0	0	0	0	0	0
	Blue(1)	0	0	0	0	0	0	0	0	0	0	0	0	0	0	0	0	0	1
	Blue(2)	0	0	0	0	0	0	0	0	0	0	0	0	0	0	0	0	1	0
	⋮	⋮	⋮	⋮	⋮	⋮	⋮	⋮	⋮	⋮	⋮	⋮	⋮	⋮	⋮	⋮	⋮	⋮	⋮
	⋮	⋮	⋮	⋮	⋮	⋮	⋮	⋮	⋮	⋮	⋮	⋮	⋮	⋮	⋮	⋮	⋮	⋮	⋮
	Blue(61)	0	0	0	0	0	0	0	0	0	0	0	0	1	1	1	1	0	1
	Blue(62)	0	0	0	0	0	0	0	0	0	0	0	0	1	1	1	1	1	0
	Blue(63)	0	0	0	0	0	0	0	0	0	0	0	0	1	1	1	1	1	1

The brightness of each primary color (red, green and blue) is based on the 8-bit gray scale data input for the color. The higher the binary input, the brighter the color. The table below provides the assignment of color versus data input.

(0: Low Level Voltage, 1: High Level Voltage)

Color		Data Signal																							
		Red								Green								Blue							
		R7	R6	R5	R4	R3	R2	R1	R0	G7	G6	G5	G4	G3	G2	G1	G0	B7	B6	B5	B4	B3	B2	B1	B0
Basic Colors	Black	0	0	0	0	0	0	0	0	0	0	0	0	0	0	0	0	0	0	0	0	0	0	0	
	Red	1	1	1	1	1	1	1	1	0	0	0	0	0	0	0	0	0	0	0	0	0	0	0	
	Green	0	0	0	0	0	0	0	0	1	1	1	1	1	1	1	1	0	0	0	0	0	0	0	
	Blue	0	0	0	0	0	0	0	0	0	0	0	0	0	0	0	0	1	1	1	1	1	1	1	
	Cyan	0	0	0	0	0	0	0	0	1	1	1	1	1	1	1	1	1	1	1	1	1	1	1	
	Magenta	1	1	1	1	1	1	1	1	0	0	0	0	0	0	0	0	1	1	1	1	1	1	1	
	Yellow	1	1	1	1	1	1	1	1	1	1	1	1	1	1	1	1	0	0	0	0	0	0	0	
	White	1	1	1	1	1	1	1	1	1	1	1	1	1	1	1	1	1	1	1	1	1	1	1	
Gray Scale Of Red	Red(0) / Dark	0	0	0	0	0	0	0	0	0	0	0	0	0	0	0	0	0	0	0	0	0	0		
	Red(1)	0	0	0	0	0	0	0	1	0	0	0	0	0	0	0	0	0	0	0	0	0	0		
	Red(2)	0	0	0	0	0	0	1	0	0	0	0	0	0	0	0	0	0	0	0	0	0	0		
	:	:	:	:	:	:	:	:	:	:	:	:	:	:	:	:	:	:	:	:	:	:	:		
	:	:	:	:	:	:	:	:	:	:	:	:	:	:	:	:	:	:	:	:	:	:	:		
	Red(253)	1	1	1	1	1	1	0	1	0	0	0	0	0	0	0	0	0	0	0	0	0	0		
	Red(254)	1	1	1	1	1	1	1	0	0	0	0	0	0	0	0	0	0	0	0	0	0	0		
	Red(255)	1	1	1	1	1	1	1	1	0	0	0	0	0	0	0	0	0	0	0	0	0	0		
Gray Scale Of Green	Green(0)/ Dark	0	0	0	0	0	0	0	0	0	0	0	0	0	0	0	0	0	0	0	0	0	0		
	Green(1)	0	0	0	0	0	0	0	0	0	0	0	0	0	0	1	0	0	0	0	0	0	0		
	Green(2)	0	0	0	0	0	0	0	0	0	0	0	0	0	1	0	0	0	0	0	0	0	0		
	:	:	:	:	:	:	:	:	:	:	:	:	:	:	:	:	:	:	:	:	:	:	:		
	:	:	:	:	:	:	:	:	:	:	:	:	:	:	:	:	:	:	:	:	:	:	:		
	Green(253)	0	0	0	0	0	0	0	0	1	1	1	1	1	1	0	1	0	0	0	0	0	0		
	Green(254)	0	0	0	0	0	0	0	0	1	1	1	1	1	1	1	0	0	0	0	0	0	0		
	Green(255)	0	0	0	0	0	0	0	0	1	1	1	1	1	1	1	1	0	0	0	0	0	0		
Gray Scale Of Blue	Blue(0) / Dark	0	0	0	0	0	0	0	0	0	0	0	0	0	0	0	0	0	0	0	0	0	0		
	Blue(1)	0	0	0	0	0	0	0	0	0	0	0	0	0	0	0	0	0	0	0	0	0	1		
	Blue(2)	0	0	0	0	0	0	0	0	0	0	0	0	0	0	0	0	0	0	0	0	0	1		
	:	:	:	:	:	:	:	:	:	:	:	:	:	:	:	:	:	:	:	:	:	:	:		
	:	:	:	:	:	:	:	:	:	:	:	:	:	:	:	:	:	:	:	:	:	:	:		
	Blue(253)	0	0	0	0	0	0	0	0	0	0	0	0	0	0	0	1	1	1	1	1	1	0		
	Blue(254)	0	0	0	0	0	0	0	0	0	0	0	0	0	0	0	1	1	1	1	1	1	1		
	Blue(255)	0	0	0	0	0	0	0	0	0	0	0	0	0	0	0	1	1	1	1	1	1	1		

6. INTERFACE TIMING

6.1 TIMING CHARACTERISTICS

The input signal timing specifications are shown as the following table and timing diagram

Parameter	Symbol	Value			Unit	Note	
		Min.	Typ.	Max.			
Vertical Display	Period	T_v	490	500	550	T_h	$T_v = T_{vd} + T_{vb}$
	Active	T_{vd}	-	480	-	T_h	-
	Blanking	T_{vb}	10	20	70	T_h	-
Horizontal Display	Period	T_h	930	992	1090	T_{clock}	$T_h = T_{hd} + T_{hb}$
	Active	T_{hd}	-	800	-	T_{clock}	-
	Blanking	T_{hb}	130	192	290	T_{clock}	-
Clock Frequency		$1/T_{clock}$	27	29.5	33	MHz	-

Note (1) Since this assembly is operated in DE only mode, Hsync and Vsync input signals should be set to low logic level. Otherwise, this assembly would operate abnormally.

(2) Frame rate is 60Hz

INPUT SIGNAL TIMING DIAGRAM

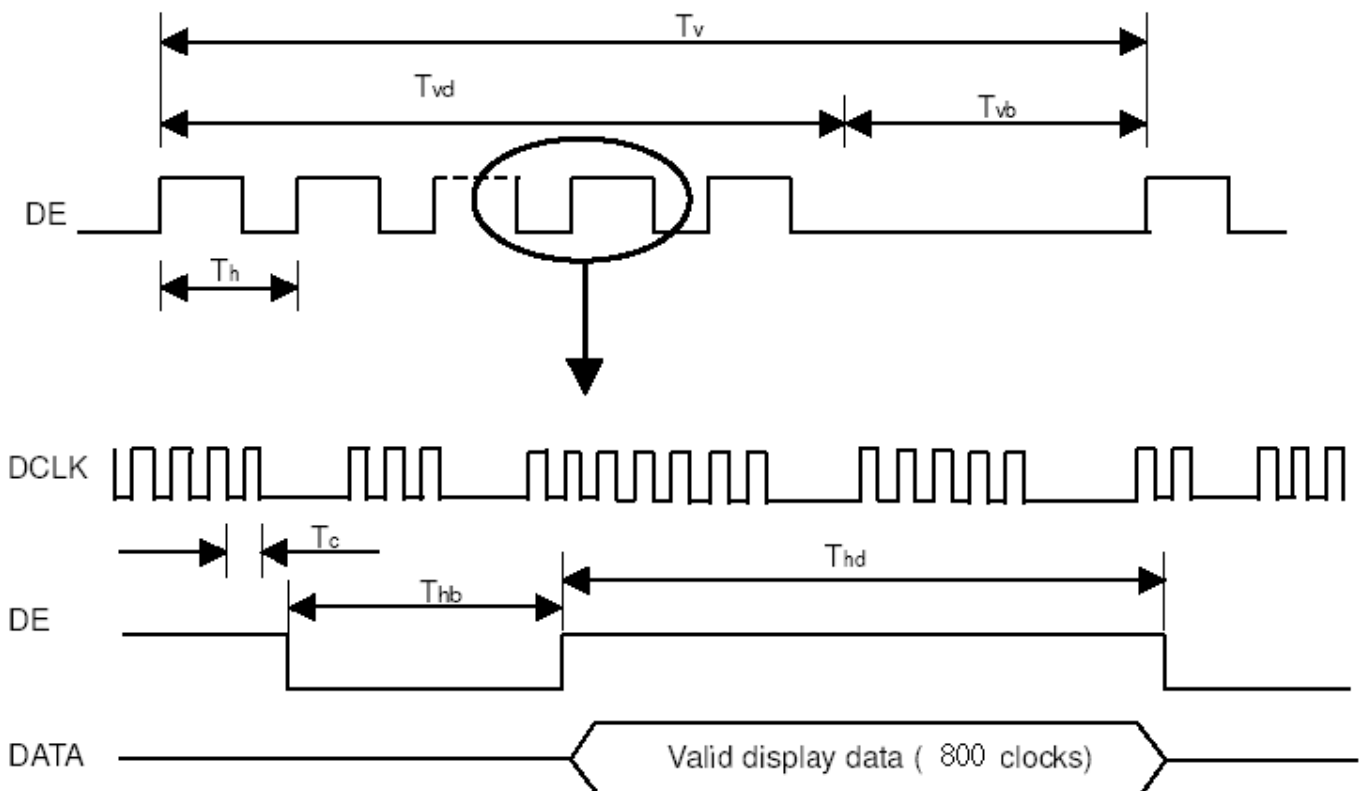

6.2 LVDS INPUT DATA FORMAT

FRC = "Low" or "NC" for 6 bits LVDS Input

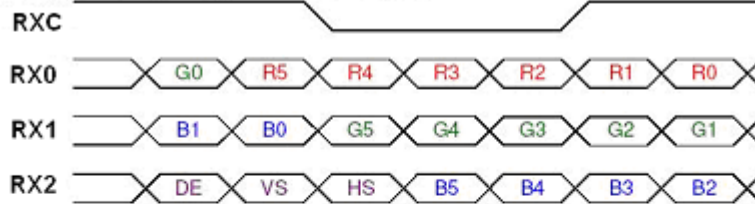

FRC = "High" for 8 bits LVDS Input

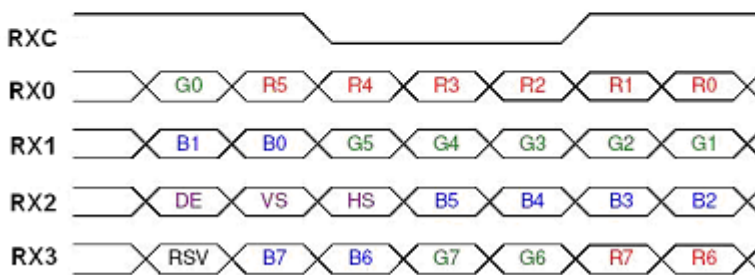

Note (1) R/G/B data 7: MSB, R/G/B data 0: LSB

Note (2) Please follow PSWG

Signal Name	Description	Remark
R7	Red Data 7 (MSB)	Red-pixel Data Each red pixel's brightness data consists of these 8 bits pixel data.
R6	Red Data 6	
R5	Red Data 5	
R4	Red Data 4	
R3	Red Data 3	
R2	Red Data 2	
R1	Red Data 1	
R0	Red Data 0 (LSB)	
G7	Green Data 7 (MSB)	Green-pixel Data Each green pixel's brightness data consists of these 8 bits pixel data.
G6	GreenData 6	
G5	GreenData 5	
G4	GreenData 4	
G3	GreenData 3	
G2	GreenData 2	
G1	GreenData 1	
G0	GreenData 0 (LSB)	
B7	Blue Data 7 (MSB)	Blue-pixel Data Each blue pixel's brightness data consists of these 8 bits pixel data.
B6	Blue Data 6	
B5	Blue Data 5	
B4	Blue Data 4	
B3	Blue Data 3	
B2	Blue Data 2	
B1	Blue Data 1	
B0	Blue Data 0 (LSB)	
RXCLKIN+ RXCLKIN-	LVDS Clock Input	
DE	Display Enable	
VS	Vertical Sync	
HS	Horizontal Sync	

Note (3) Output signals from any system shall be low or Hi-Z state when VCC is off.

6.3 POWER ON/OFF SEQUENCE

To prevent a latch-up or DC operation of LCD assembly, the power on/off sequence should be as the diagram below

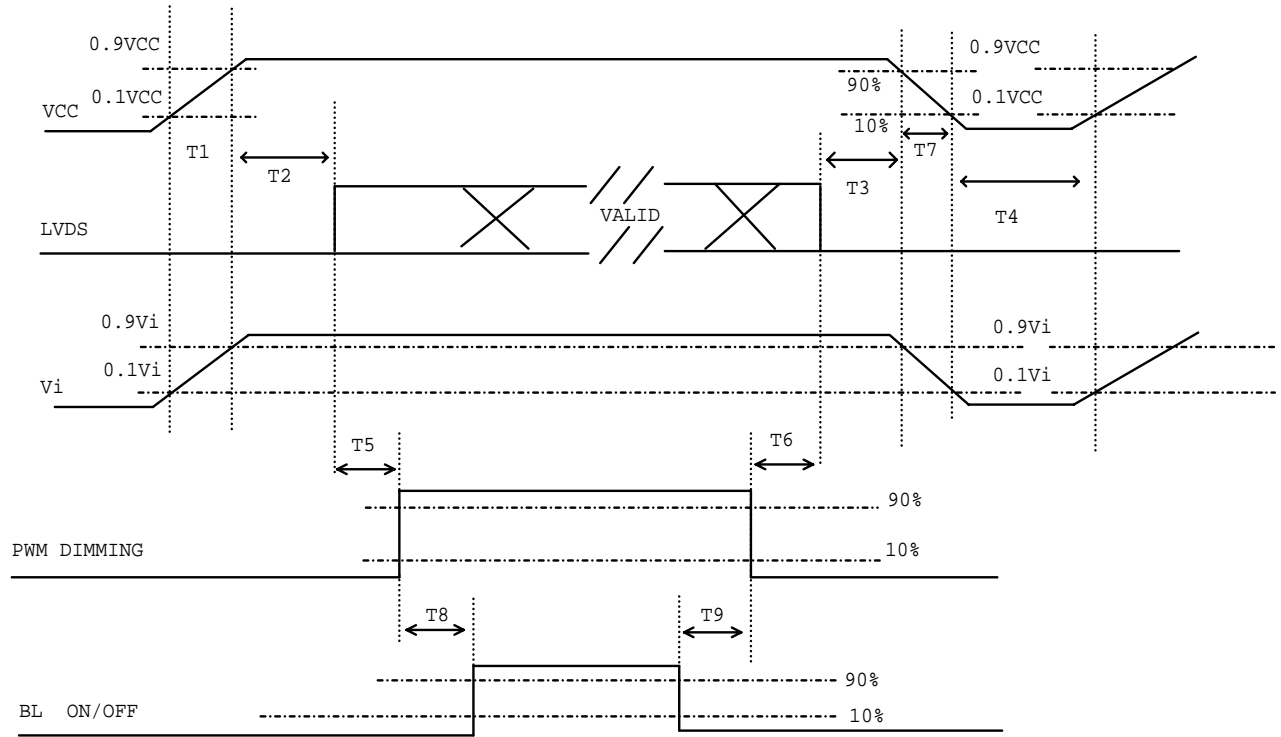

Power ON/OFF sequence

Note (1) Please avoid floating state of interface signal at invalid period.

Note (2) When the interface signal is invalid, be sure to pull down the power supply of LCD VCC to 0 V.

Note (3) The Backlight converter power must be turned on after the power supply for the logic and the interface signal is valid. The Backlight converter power must be turned off before the power supply for the logic and the interface signal is invalid.

Parameter	Value			Units
	Min	Typ	Max	
T1	0.5	-	10	ms
T2	0	-	50	ms
T3	0	-	50	ms
T4	500	-	-	ms
T5	20	-	-	ms
T6	10	-	-	ms
T7	5	-	300	ms
T8	10	-	-	ms
T9	10	-	-	ms

7. OPTICAL CHARACTERISTICS

7.1 TEST CONDITIONS

Item	Symbol	Value	Unit
Ambient Temperature	Ta	25±2	°C
Ambient Humidity	Ha	50±10	%RH
Supply Voltage	V _{CC}	3.3	V
Input Signal	According to typical value in "3. ELECTRICAL CHARACTERISTICS"		
Current	I _f	60±4	mA
Converter Duty		100	%

Note (1) I_f means the forward current of each channel

7.2 OPTICAL SPECIFICATIONS

The relative measurement methods of optical characteristics are shown in 7.2. The following items should be measured under the test conditions described in 7.1 and stable environment shown in Note (6).

Item	Symbol	Condition	Min.	Typ.	Max.	Unit	Note					
Color Chromaticity	Red	$\theta_x=0^\circ, \theta_y=0^\circ$ Viewing Normal Angle	Typ - 0.03	0.645	Typ + 0.03		(1), (6)					
				Ry				0.341				
	Green			Gx				0.312				
				Gy				0.625				
	Blue			Bx				0.153				
				By				0.053				
	White			Wx				0.313				
				Wy				0.329				
	Center Luminance of White			L _C				400	500		cd/m ²	(4), (6)
	Contrast Ratio			CR				500	600		-	(2), (6)
Response Time	T _R		5	10	Ms	(3)						
	T _F		11	16	Ms							
White Variation	δW		1.25	1.4	-	(5), (6)						
Viewing Angle	Horizontal	CR 10		60	70		Deg. (1), (6)					
				θ _{x-}	60			70				
	Vertical			θ _{y+}	50			60				
				θ _{y-}	50			60				

Note (1) Definition of Viewing Angle (θ_x, θ_y):

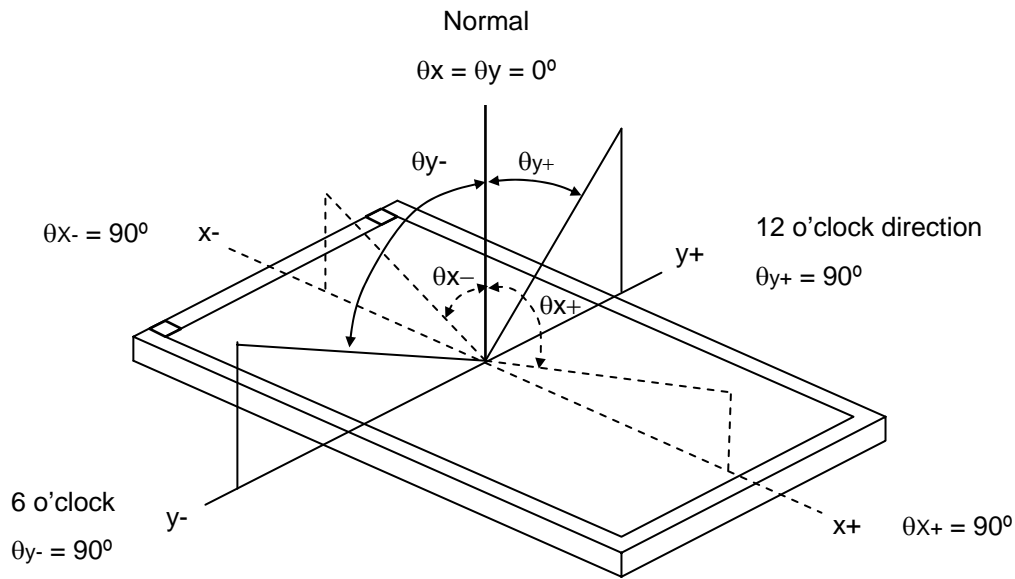

Note (2) Definition of Contrast Ratio (CR):

The contrast ratio can be calculated by the following expression.

$$\text{Contrast Ratio (CR)} = L_{63} / L_0$$

L63: Luminance of gray level 63

L 0: Luminance of gray level 0

$$\text{CR} = \text{CR} (5)$$

CR (X) is corresponding to the Contrast Ratio of the point X at Figure in Note (5).

Note (3) Definition of Response Time (T_R, T_F) and measurement method:

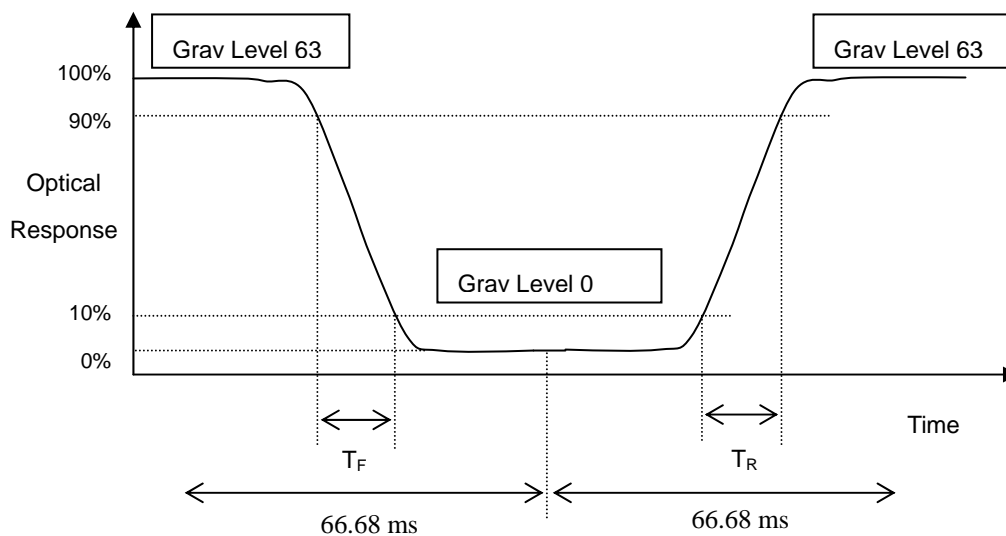

Note (4) Definition of Luminance of White (L_C):

Measure the luminance of gray level 63 at center point

$$L_C = L(5)$$

$L(x)$ is corresponding to the luminance of the point X at Figure in Note (5).

Note (5) Definition of White Variation (δW):

Measure the luminance of gray level 63 at 5 points

$$\delta W = \text{Maximum} [L(1), L(2), L(3), L(4), L(5)] / \text{Minimum} [L(1), L(2), L(3), L(4), L(5)]$$

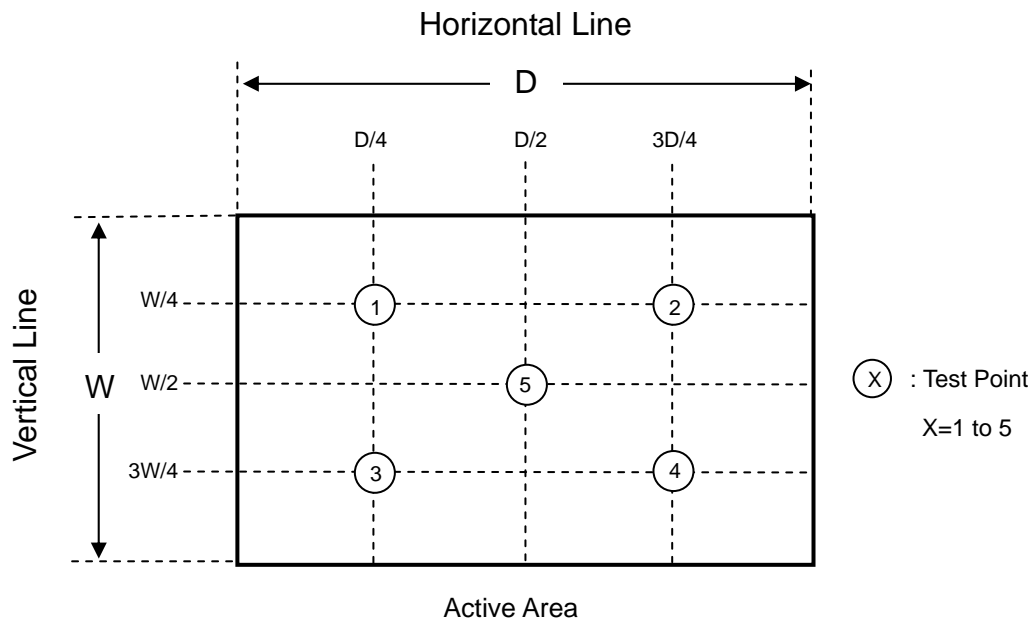

Note (6) Measurement Setup:

The LCD module should be stabilized at given temperature for 20 minutes to avoid abrupt temperature change during measuring. In order to stabilize the luminance, the measurement should be executed after lighting Backlight for 20 minutes in a windless room.

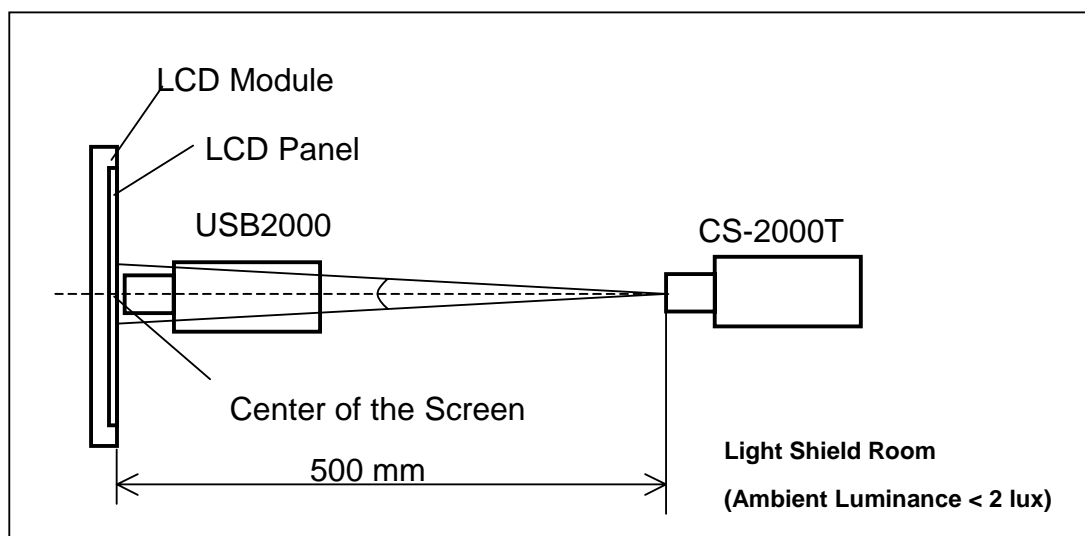

8. RELIABILITY TEST

8.1 RELIABILITY TEST CONDITION

No.	Test Item	Test Condition	Note
1	High Temperature Storage	95 , 240 hours	(1) (2)
2	Low Temperature Storage	-40 , 240 hours	
3	Thermal Shock Storage	{{(-40 , 0.5 hour) (85 , 0.5 hour)}, 100 cycles	
4	High Temperature Operating	85 , 240 hours	
5	Low Temperature Operating	-30 , 240 hours	
6	High Temperature & High Humidity Operating	60 , 90% RH, 240hours	
7	Shock (Non-Operating)	100G, 6ms, half sine wave, 3 times for $\pm X$, $\pm Y$, $\pm Z$.	(3)
8	Vibration (Non-Operating)	3G, 10 ~ 200 Hz, 10min/cycle, 3 cycles each X, Y, Z	(3)

Note (1) There should be no condensation on the surface of panel during test.

Note (2) The temperature of panel display surface area should be 95 Max.

Note (3) At testing Vibration and Shock, the fixture in holding the module has to be hard and rigid enough so that the module would not be twisted or bent by the fixture.

Note (4) In the standard conditions, there is no function failure issue occurred. All the cosmetic specification is judged before the reliability test.

9. PACKAGING

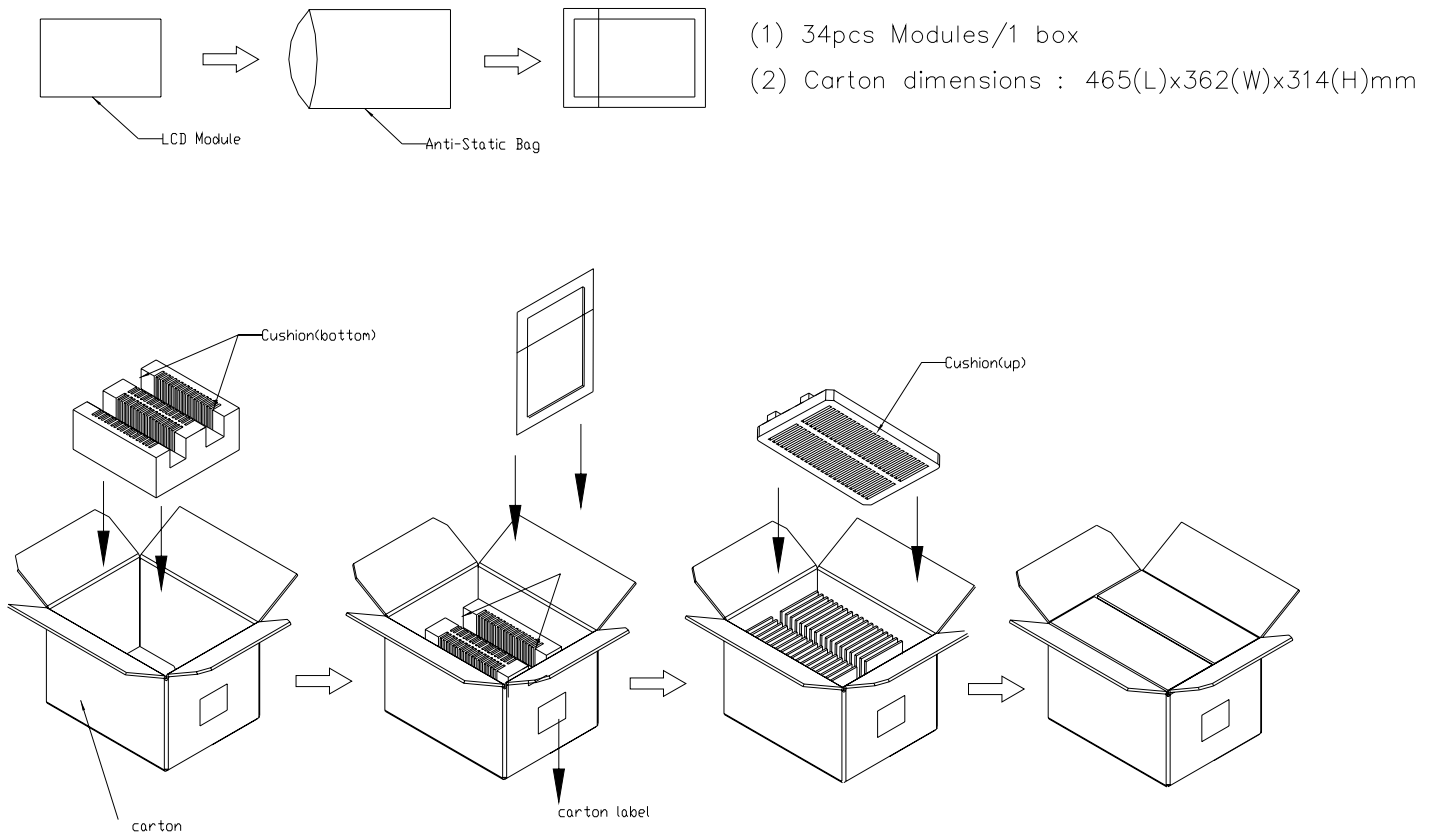

Sea / Land Transportation (40ft Container)

Air Transportation

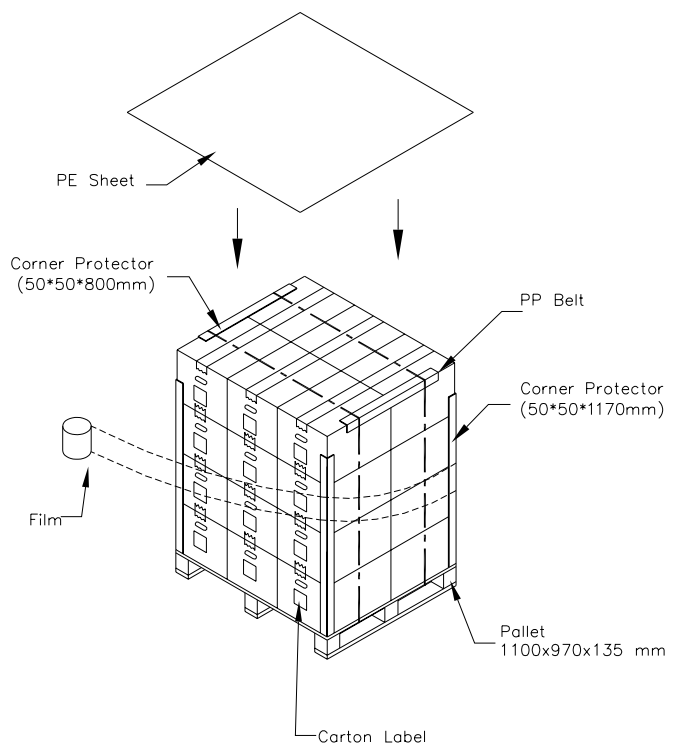
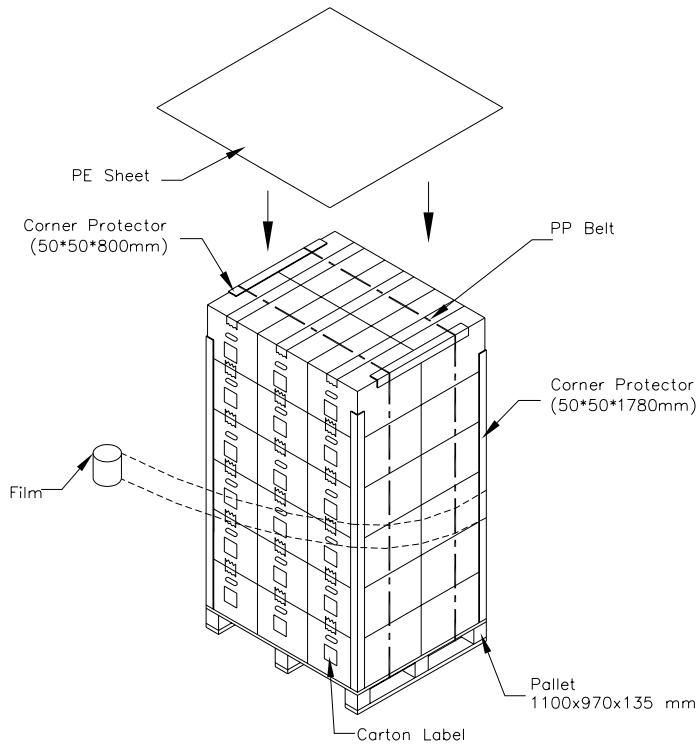

10. DEFINITION OF LABELS

10.1 CMO MODULE LABEL

The barcode nameplate is pasted on each module as illustration, and its definitions are as following explanation.

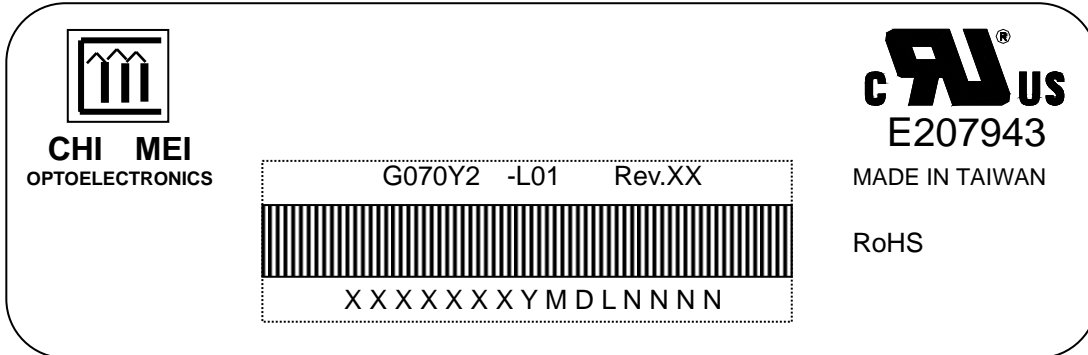

- (a) Model Name: G070Y2 -L01
- (b) Revision: Rev. XX, for example: A1, ..., C1, C2 ...etc.
- (c) Serial ID: XXXXXXXXYMDXNNNN

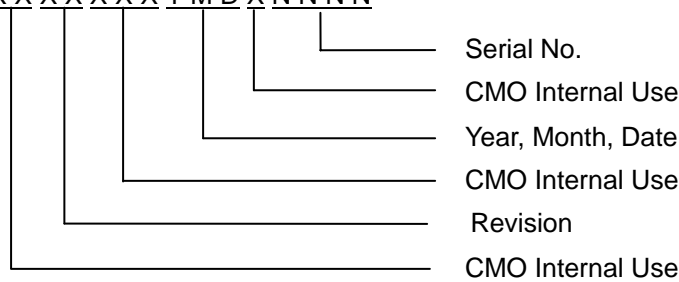

Serial ID includes the information as below:

- (a) Manufactured Date: Year: 1~9, for 2001~2009
 Month: 1~9, A~C, for Jan. ~ Dec.
 Day: 1~9, A~Y, for 1st to 31st, exclude I, O and U
- (b) Revision Code: cover all the change
 Serial No.: Manufacturing sequence of product

11. PRECAUTIONS

11.1 ASSEMBLY AND HANDLING PRECAUTIONS

- (1) Do not apply rough force such as bending or twisting to the module during assembly.
- (2) To assemble or install module into user's system can be only in clean working areas. The dust and oil may cause electrical short or worsen the polarizer.
- (3) It's not permitted to have pressure or impulse on the module because the LCD panel and Backlight will be damaged.
- (4) Always follow the correct power sequence when LCD module is connecting and operating. This can prevent damage to the CMOS LSI chips during latch-up.
- (5) Do not pull the I/F connector in or out while the module is operating.
- (6) Do not disassemble the module.
- (7) Use a soft dry cloth without chemicals for cleaning, because the surface of polarizer is very soft and easily scratched.
- (8) It is dangerous that moisture come into or contacted the LCD module, because moisture may damage LCD module when it is operating.
- (9) High temperature or humidity may reduce the performance of module. Please store LCD module within the specified storage conditions.
- (10) When ambient temperature is lower than 10°C may reduce the display quality. For example, the response time will become slowly, and the starting voltage of CCFL will be higher than room temperature.
- (11) Do not keep same pattern in a long period of time. It may cause image sticking on LCD

11.2 SAFETY PRECAUTIONS

- (1) Do not disassemble the module or insert anything into the Backlight unit to prevent electrical shock.
- (2) If the liquid crystal material leaks from the panel, it should be kept away from the eyes or mouth. In case of contact with hands, skin or clothes, it has to be washed away thoroughly with soap.
- (3) After the module's end of life, it is not harmful in case of normal operation and storage.

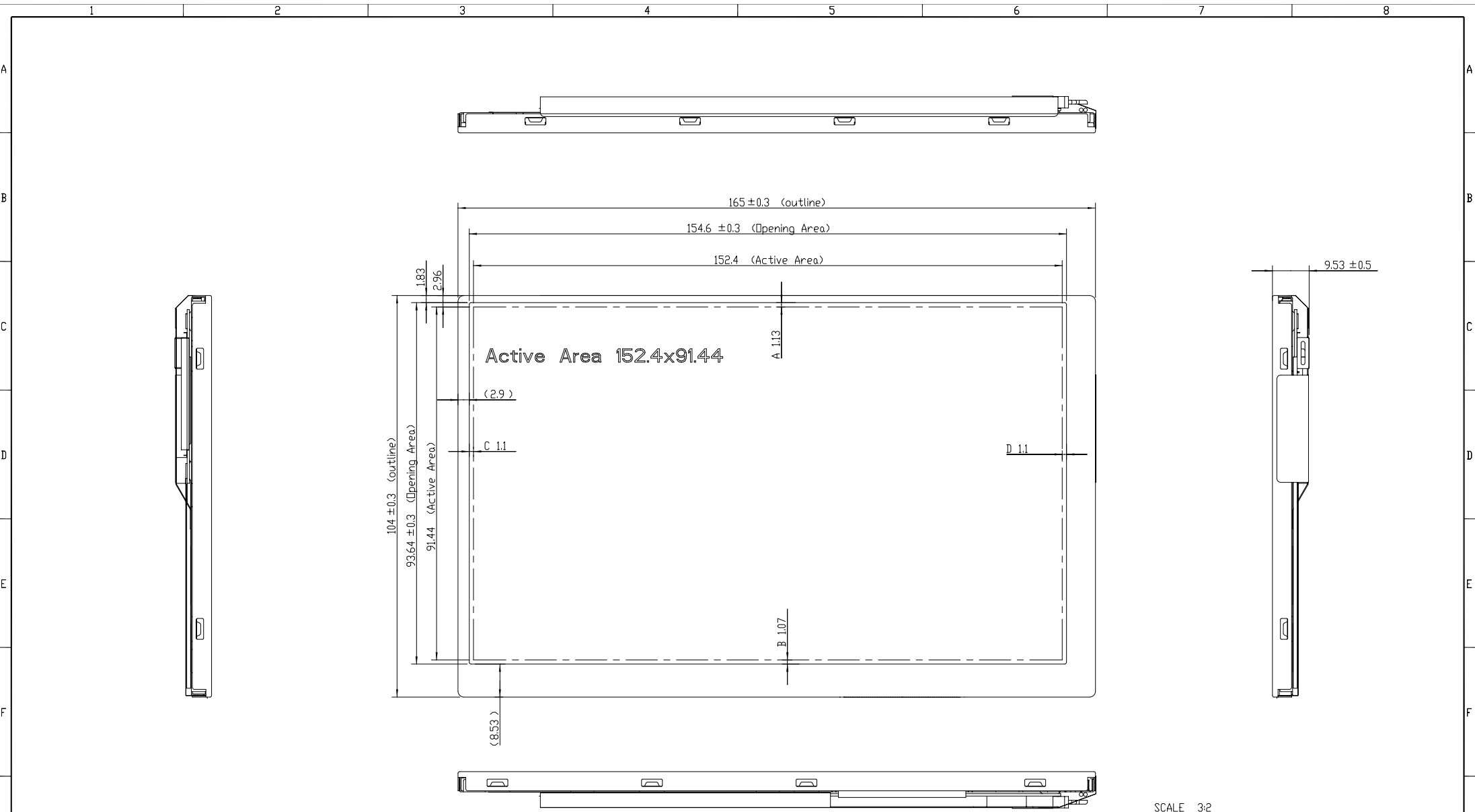

Note:
 1.UNSPECIFIED TOLERANCE= ± 0.3 mm.
 2.DISPLAY AREA POSITION TOLERANCE: IA-BK=1mm & IC-DK=1mm.
 3.LVDS CONNECTOR: 73B20-0048RA-G4 (Starcon).
 4.P/I CONNECTOR: LM123S004HTF13 (Unicorn).
 5.THOSE SCREWS AT PCBA BOARD TO TWIST WITH FORCE IS 0.6 Kgf-cm AND REPEAT TIMES<= 4 .
 6.THE WIRE IS UNDER THE PCB PROTECTOR FILM.

SCALE 3:2

Mark	Description	Date	Changed_By	Approved_By	ECN No.	Remark

TITLE	ASSY_MODULE_G070Y2-L01			2D REV. A
Approved	KL_Lin	Drawing No.	G07024101A	
Checked	TIGER	Part No.	TBD	
Drawer	MIROR_CHEN	Material	TBD	Sheet 1 / 2 A2
Designer	MIROR_CHEN	Date	15-Oct-2009	Scale 1:1 Unitmm
		CHI MEI OPTOELECTRONICS CORP. ALL RIGHTS RESERVED, COPYING FORBIDDEN.		

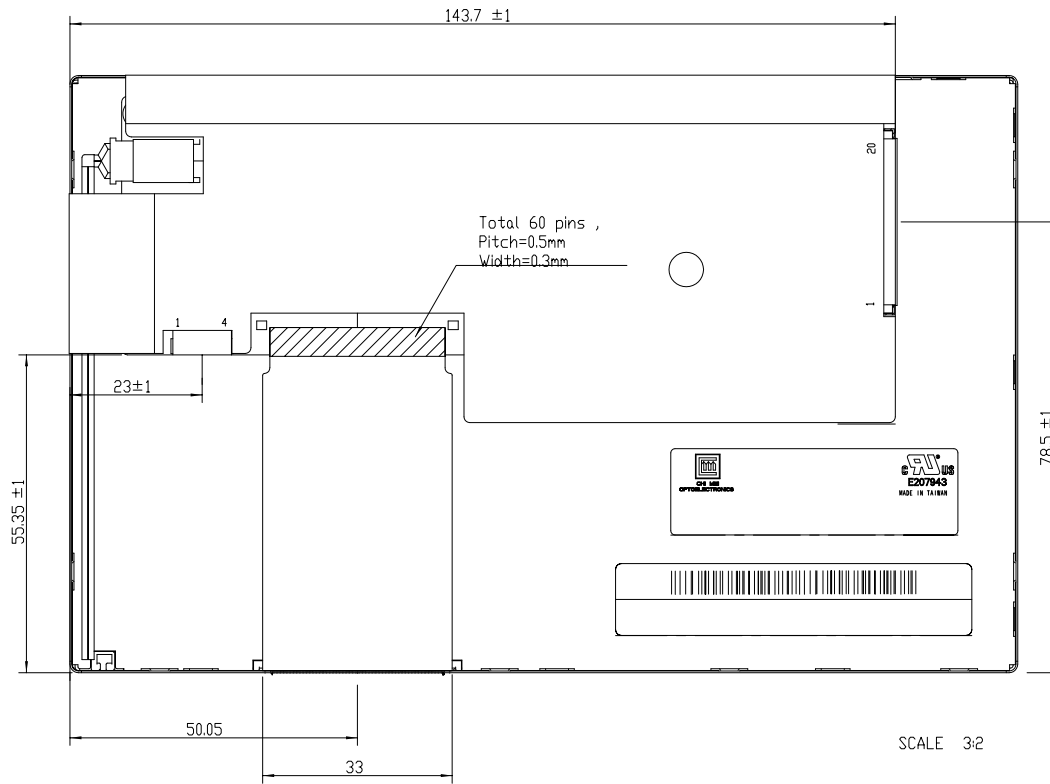

Note:
 1.UNSPECIFIED TOLERANCE=±0.3mm.
 2.DISPLAY AREA POSITION TOLERANCE: IA-BK=1mm & IC-DK=1mm.
 3.LVDS CONNECTOR: 73B20-0048RA-G4 (Starcon).
 4.P/I CONNECTOR: LM123S004HTF13 (Unicorn).
 5.THOSE SCREWS AT PCBA BOARD TO TWIST WITH FORCE IS 0.6 KgF-cm AND REPEAT TIMES<= 4 .
 6.THE WIRE IS UNDER THE PCB PROTECTOR FILM.

TITLE	ASSY_MODULE_G070Y2-L01			2D REV. A
				3D REV. 1.23+
Approved	KL_Lin	Drawing No.	G07024101A	
Checked	TIGER	Part No.	TBD	
Drawer	MIROR_CHEN	Material	TBD	Sheet 2 / 2 A2
Designer	MIROR_CHEN	Date	15-Oct-2009	Scale 1:1 Unitmm
		CHI MEI OPTOELECTRONICS CORP. ALL RIGHTS RESERVED, COPYING FORBIDDEN.		

Mark	Description	Date	Changed_By	Approved_By	ECN No.	Remark
1						
2						
3						
4						
5						
6						
7						
8						