

DRA300 SERIES



AC - DC DIN RAIL MOUNTABLE POWER SUPPLY
INDUSTRIAL CONTROL EQUIPMENT

FEATURES

- P.F.C. FUNCTION AVAILABLE
- PARALLEL FUNCTION AVAILABLE (SWITCH)
- INPUT VOLTAGE 115/230VAC AUTO SELECT
- SELV COMPONENTS DESIGN

SELECTION CHART

DRA 300 - 24 x

Wattage

24 : 24VOUT
48 : 48VOUT

A : SCREW TERMINAL TYPE
B : DETACHABLE CONNECTOR TYPE

MODEL LIST

MODEL NO.	INPUT VOLTAGE	OUTPUT WATTAGE	OUTPUT VOLTAGE	OUTPUT CURRENT	EFF. (min.)	EFF. (typ.)
Single Output Models						
DRA300-24x	115 / 230 VAC	300 WATTS	+ 24 VDC	12.5A	87%	89%
DRA300-48x	115 / 230 VAC	300 WATTS	+ 48 VDC	6.25A	88%	90%

SPECIFICATION

All Specifications Typical At Nominal Line, Full Load, 25°C Unless Otherwise Noticed

GENERAL						
Characteristics	Conditions		min.	typ.	max.	unit
Switching frequency	Vi nom, Io nom			40		KHz
Isolation voltage	Input-Output		3000 / 4242			VAC / VDC
	Input-FG		1500 / 2121			VAC / VDC
Isolation resistance	Input-Output, @ 500VDC		100			MΩ
Ambient temperature	Operating at Vinom		-25		+ 71	°C
Derating (see derating curve)	Vi nom, from +56 to +71°C				2.5	% / °C
Storage temperature	Non operational		-25		+ 85	°C
Relative humidity	Vi nom, Io nom		20		95	% RH
Temperature coefficient	Vi nom, Io min				± 0.03	% / °C
MTBF	Bellcore Issue 6 @40°C, GB	24V model		415000		Hours
		48V model		431000		Hours
Altitude during operation					2000	m
Dimension	Screw terminal type		L124.5 x W83.5 x D123.6			mm
	Detachable connector type		L143.5 x W83.5 x D123.6			mm
Cooling	Free air convection					
Pollution degree			2			

SPECIFICATION

All Specifications Typical At Nominal Line, Full Load, 25°C Unless Otherwise Noticed

INPUT SPECIFICATIONS

Characteristics	Conditions			min.	typ.	max.	unit
Rated input voltage	Io nom			115 / 230 (auto select)			VAC
Input voltage range	Ta min ... Ta max, Io nom	AC in	115V selected	90		132	VAC
		AC in	230V selected	180		264	VAC
		DC in		210		375	VDC
Rated input current	Vi : 115 / 230 VAC, Io nom				4.8 / 1.9	6.0 / 3.0	A
Line frequency	Vi nom, Io nom			47		63	Hz
Inrush current	Vi : 115 / 230 VAC , Io nom					35 / 65	A
Power dissipation	Vi : 230 VAC, Io nom	24V model			42		W
		48V model			40		W
Leakage current	Input-Output					0.25	mA
	Input-FG					3.5	mA
P.F.C. (Passive)	Vi : 230VAC, Io nom				0.75		

OUTPUT SPECIFICATIONS

Characteristics	Conditions			min.	typ.	max.	unit
Output voltage accuracy (Adjusted before shipment)	Vi nom, Io max			0		+ 1	%
Minimum load	Vi nom			0			%
Line regulation	Io nom, Vi min ... Vi max					± 0.5	%
Load regulation	Vi nom, Io min ... Io nom	single mode				± 1	%
		parallel mode				± 5	%
Voltage trim range	Vi nom, 0.8 Io nom	24V model		22.5		28.5	VDC
		48V model		47		56	VDC
Rated continuous loading	Vi nom	24V model		12.5A @ 24Vdc / 10.5A @ 28.5 Vdc			
		48V model		6.25A @ 48Vdc / 5.35A @ 56 Vdc			
Hold up time	Vi : 115 / 230 VAC , Io nom			25 / 30			ms
Turn on time	Vi nom, Io nom					1000	ms
	Vi nom, Io nom → with 7000 μF CAP					1500	ms
Rise time	Vi nom, Io nom					150	ms
	Vi nom, Io nom → with 7000 μF CAP					500	ms
Fall time	Vi nom, Io nom					150	ms
Transient recovery time	Vi nom, I ~ 0.5 Io nom					2	ms
Ripple & noise	Vi nom, Io nom, BW = 20MHz					100	mV
Power back immunity	Vi nom, Io nom	24V model		35			VDC
		48V model		63			VDC
Capacitor load	Vi nom, Io nom					7000	μF
DC ON indicator threshold at start up (Green LED)	Vi nom, Io nom	24V model		17.6		19.4	VDC
		48V model		37		43	VDC
DC LOW indicator threshold after start up (Red LED)	Vi nom, Io nom	24V model		17.6		19.4	VDC
		48V model		37		43	VDC
Parallel operation	0.1 Io min ~ 0.9 Io max					3	unit
Efficiency	Vi nom, Io nom, Po / Pi			Up to 90%, See model list and typ efficiency curve			

CONTROL AND PROTECTION

Characteristics	Conditions			min.	typ.	max.	unit
Input fuse				T8A / 250VAC internal			
Internal surge voltage protection	IEC 61000-4-5			Varistor			
Rated over load protection	Vi nom (see typ current limited curve)			120		145	%
Power Rdy (for 24V model only)	Threshold voltage of contact closed(at start up)			17.6		19.4	VDC
	Electrical isolation			500			VDC
	Contact rating at 60VDC					0.3	A
Over voltage protection	Vi nom, Io nom (Auto Recovery)			125		140	%
Output short circuit				Fold forward			
Degree of protection				IP20			

SPECIFICATION

All Specifications Typical At Nominal Line, Full Load, 25°C Unless Otherwise Noticed

APPROVALS AND STANDARDS

UL / cUL	UL 508 Listed UL 60950-1 Recognized ISA 12.12.01(Class I, Division 2, Groups A, B, C and D)
TUV	EN 60950-1, CB scheme EN 61558-1, EN 61558-2-17 (meet EN 60204)
CE	EN 61000-6-3, EN 55022 Class B, EN 61000-3-2 Class D, EN 61000-3-3 EN 61000-6-2, EN 55024, EN 61000-4-2 Level 4, EN 61000-4-3 Level 3 EN 61000-4-4 Level 4, EN 61000-4-5 L-N Level 3, L / N-FG Level 4 EN 61000-4-6 Level 3, EN 61000-4-8 Level 4, EN 61000-4-11 ENV 50204 Level 2, EN 61204-3
Vibration resistance	meet IEC 60068-2-6 (Mounting by rail : 10-500 Hz, 2G, along X, Y, Z each Axis, 60 min for each Axis)
Shock resistance	meet IEC 60068-2-27 (15G, 11ms, 3 Axis, 6 Faces, 3 times for each Face)

PHYSICAL CHARACTERISTICS

Case size	Screw terminal type	124.5 x 83.5 x 123.6 mm (4.9 x 3.29 x 4.87 inches)
	Detachable connector type	143.5 x 83.5 x 123.6 mm (5.65 x 3.29 x 4.87 inches)
Case material	Metal	
Weight	1400g	
Packing	1.53kg ; 16 pcs / 25.5kg / 2.01CUFT	

MECHANISM & PIN CONFIGURATION

mm [inch]

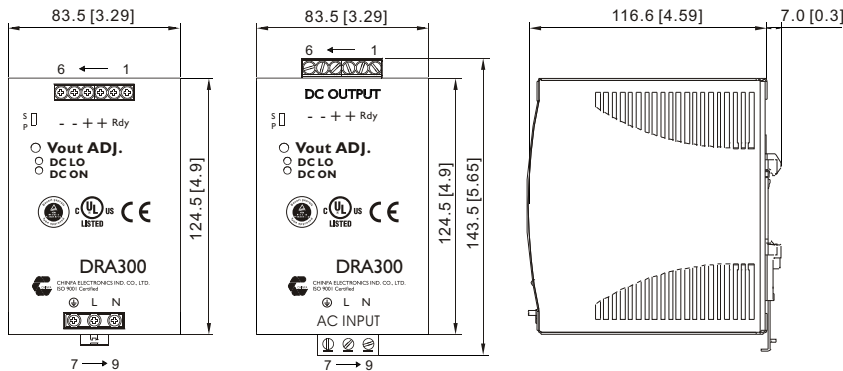

CONSTRUCTION

Easy snap-on mounting onto the DIN-Rail (TS35/7.5 or TS35/15), unit sits safely and firmly on the rail.

INSTALLATION

Ventilation / Cooling
Normal convection
All sides 25mm free space
For cooling recommended

Connector size range
Screw terminal:
AWG24-10 (0.2~4mm²) flexible / solid cable,
-Input connector can withstand torque at maximum 9 pound-inches.
-Output connector can withstand torque at maximum 5.5 pound-inches.
8 m/m stripping at cable end recommends

Detachable connector:
AWG24-12 (0.2~2.5mm²) flexible / solid cable,
-Input connector can withstand torque at maximum 4.5 pound-inches.
-Output connector can withstand torque at maximum 7 pound-inches.
4~5 m/m stripping at cable end recommends

Use copper conductors only, 60 / 75°C

PIN ASSIGNMENT

PIN NO.	Designation	Description
1	OUT	RDY
2		A normal open relay contact for DC ON level control (Never connect except 24V model)
3, 4		V +
5, 6	V -	Negative output terminal
7	IN	⊕
8		L
9		N
	OTHER	DC ON
		DC LO
		Vout Adj.
		S / P
		Operation indicator LED
		DC LOW voltage indicator LED
		Trimmer-potentiometer for Vout adjustment
		Single / Parallel select switch

CIRCUIT SCHEMATIC

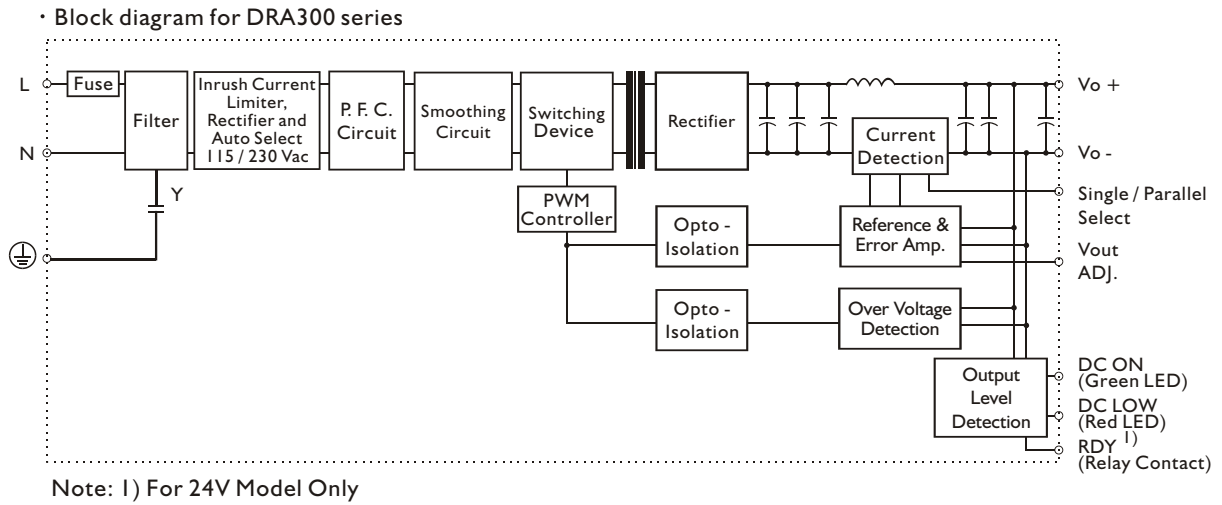

TYP. CURRENT LIMITED CURVE

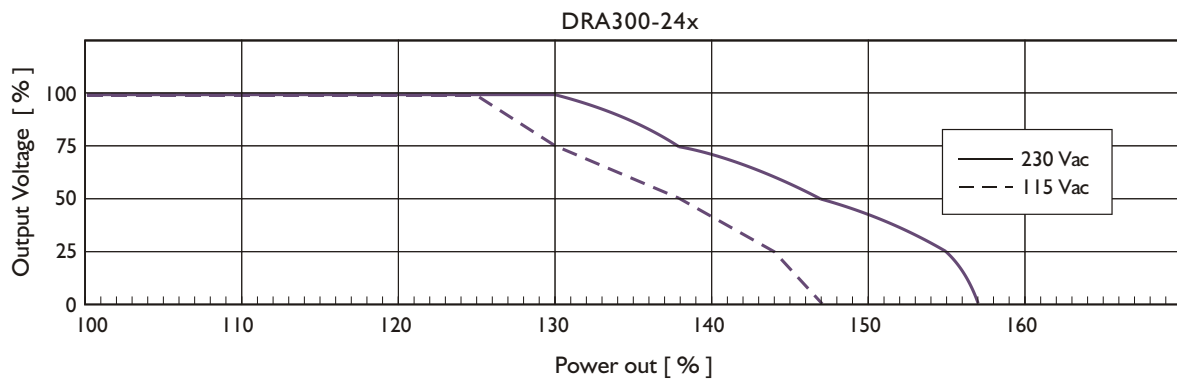

DERATING CURVE

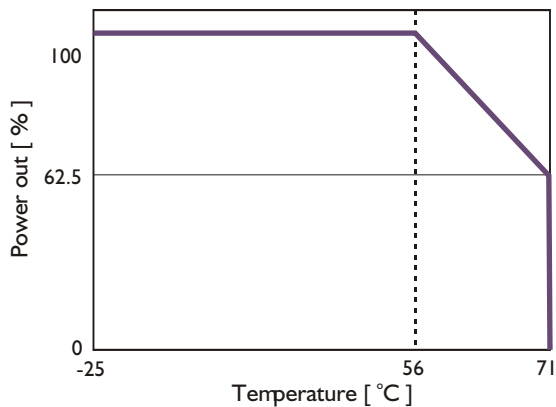

TYP. EFFICIENCY CURVE

