

Engineering reference data are not verified. The specifications are subject to change without notice.

DomiLED InGaN White High CRI – DDW-KJC

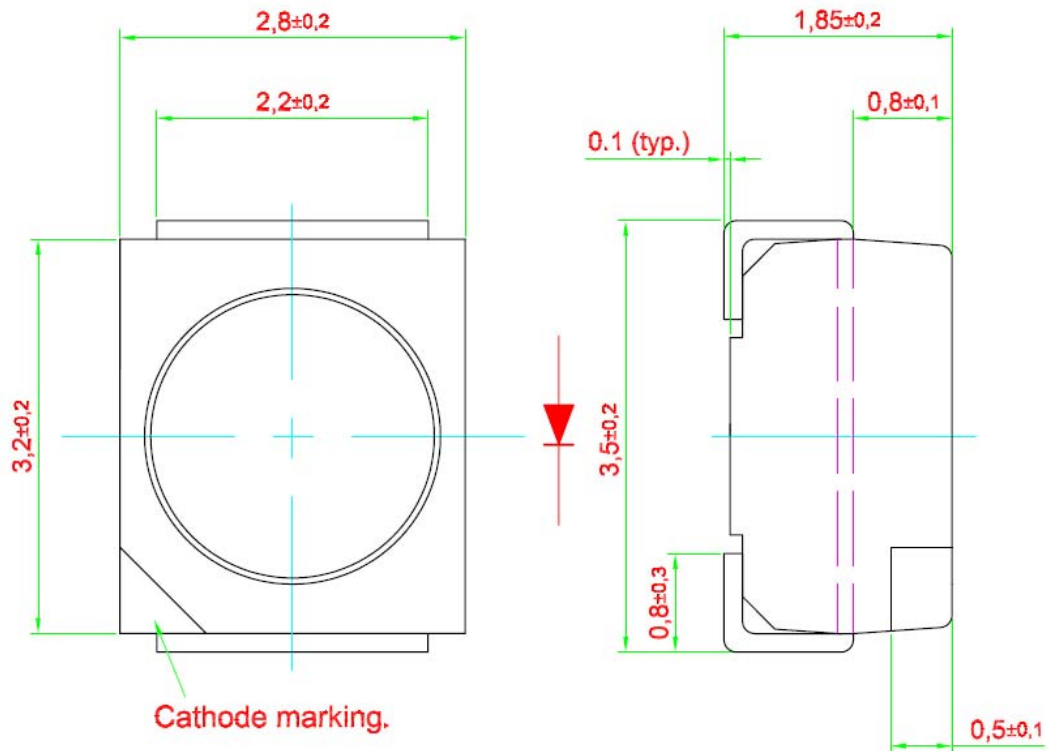

- High brightness surface mount LED.
- High color rendering index (CRI). 75 min; 80 typical.
- 120° viewing angle.
- Small package outline.
- Qualified according to JEDEC moisture sensitivity Level 2.
- Compatible to both IR reflow soldering and TTW soldering.

Engineering reference data are not verified. The specifications are subject to change without notice.

Optical Characteristics at Tj=25°C.

Part Ordering Number	Chip Technology / Color	Viewing angle	Luminous Intensity @ If=20mA
DDW-KJC-W2X1-1	InGaN / White	120	1800 (typ) 1400 - 2240

NOTE:

1. All part number above comes in a quantity of 2000 units per reel.
2. Luminous intensity is measured with an accuracy of ±11%.
3. Color binning is carried for all units as per the color-binning table. Only one color group is allowed for each reel.

IV Bin	Intensity @ If = 20mA (mcd)	
	Min	Max
W2	1400	1800
X1	1800	2240

Electrical Characteristics at Tj=25°C.

Part Number	Vf @ If = 20mA			Vr @ Ir = 10uA
	Min. (V)	Typ. (V)	Max. (V)	Min.(V)
DDW-KJC	2.9	3.2	3.5	5

Forward voltage, Vf is measured with an accuracy of ±0.1 V.

Vf Binning (Optional)

Vf Bin @ 20mA	Forward voltage (V)
V1	2.90 ... 3.00
V2	3.00 ... 3.10
V3	3.10 ... 3.20
V4	3.20 ... 3.30
V5	3.30 ... 3.40
V6	3.40 ... 3.50

Forward voltage, Vf is measured with an accuracy of ±0.1 V.

Engineering reference data are not verified. The specifications are subject to change without notice.

Color Group

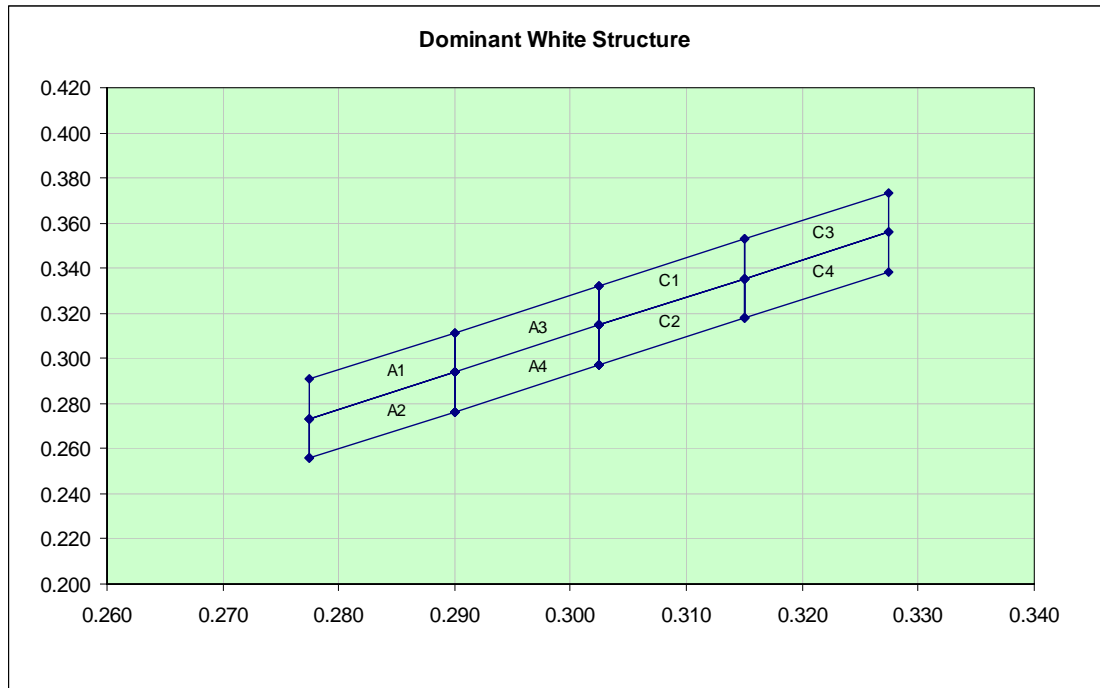

Chromaticity coordinate groups are measured with an accuracy of ± 0.01 .

A1	Cx	0.2775	0.2900	0.2900	0.2775	0.2775
	Cy	0.2732	0.2939	0.3114	0.2907	0.2732
A2	Cx	0.2775	0.2900	0.2900	0.2775	0.2775
	Cy	0.2557	0.2764	0.2939	0.2732	0.2557
A3	Cx	0.2900	0.3025	0.3025	0.2900	0.2900
	Cy	0.2939	0.3146	0.3321	0.3114	0.2939
A4	Cx	0.2900	0.3025	0.3025	0.2900	0.2900
	Cy	0.2764	0.2971	0.3146	0.2939	0.2764
C1	Cx	0.3025	0.3150	0.3150	0.3025	0.3025
	Cy	0.3146	0.3353	0.3529	0.3321	0.3146
C2	Cx	0.3025	0.3150	0.3150	0.3025	0.3025
	Cy	0.2971	0.3179	0.3353	0.3146	0.2971
C3	Cx	0.3150	0.3275	0.3275	0.3150	0.3150
	Cy	0.3353	0.3561	0.3736	0.3529	0.3353
C4	Cx	0.3150	0.3275	0.3275	0.3150	0.3150
	Cy	0.3179	0.3386	0.3561	0.3353	0.3179

Engineering reference data are not verified. The specifications are subject to change without notice.

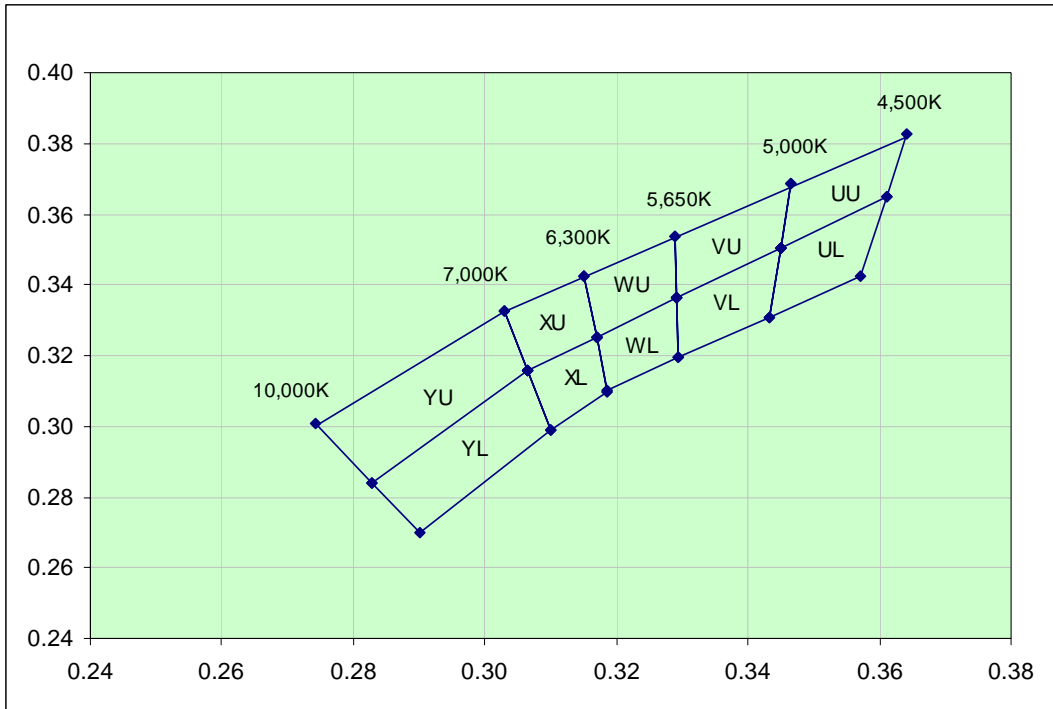

Chromaticity coordinate groups are measured with an accuracy of ± 0.01 .

Bin		1	2	3	4
YU	Cx	0.274	0.283	0.307	0.303
	Cy	0.301	0.284	0.316	0.333
YL	Cx	0.283	0.290	0.310	0.307
	Cy	0.284	0.270	0.299	0.316
XU	Cx	0.303	0.307	0.317	0.315
	Cy	0.333	0.316	0.325	0.343
XL	Cx	0.307	0.310	0.319	0.317
	Cy	0.316	0.299	0.310	0.325
WU	Cx	0.315	0.317	0.329	0.329
	Cy	0.343	0.325	0.336	0.354
WL	Cx	0.317	0.319	0.329	0.329
	Cy	0.325	0.310	0.319	0.336
VU	Cx	0.329	0.329	0.345	0.347
	Cy	0.354	0.336	0.350	0.368
VL	Cx	0.329	0.329	0.343	0.345
	Cy	0.336	0.319	0.331	0.350
UU	Cx	0.347	0.345	0.361	0.364
	Cy	0.368	0.350	0.365	0.383
UL	Cx	0.345	0.343	0.357	0.361
	Cy	0.350	0.331	0.343	0.365

Engineering reference data are not verified. The specifications are subject to change without notice.

Absolute Maximum Ratings.

	Maximum Value	Unit
DC forward current.	50	mA
Peak pulse current; ($t_p \leq 10 \mu s$, Duty cycle = 0.005)	100	mA
Reverse voltage; I_r (max) = $10 \mu A$.	5	V
LED junction temperature.	125	°C
Operating temperature.	-40 ... +100	°C
Storage temperature.	-40 ... +100	°C
Power dissipation (at room temperature)	80	mW

Recommended Solder Pad

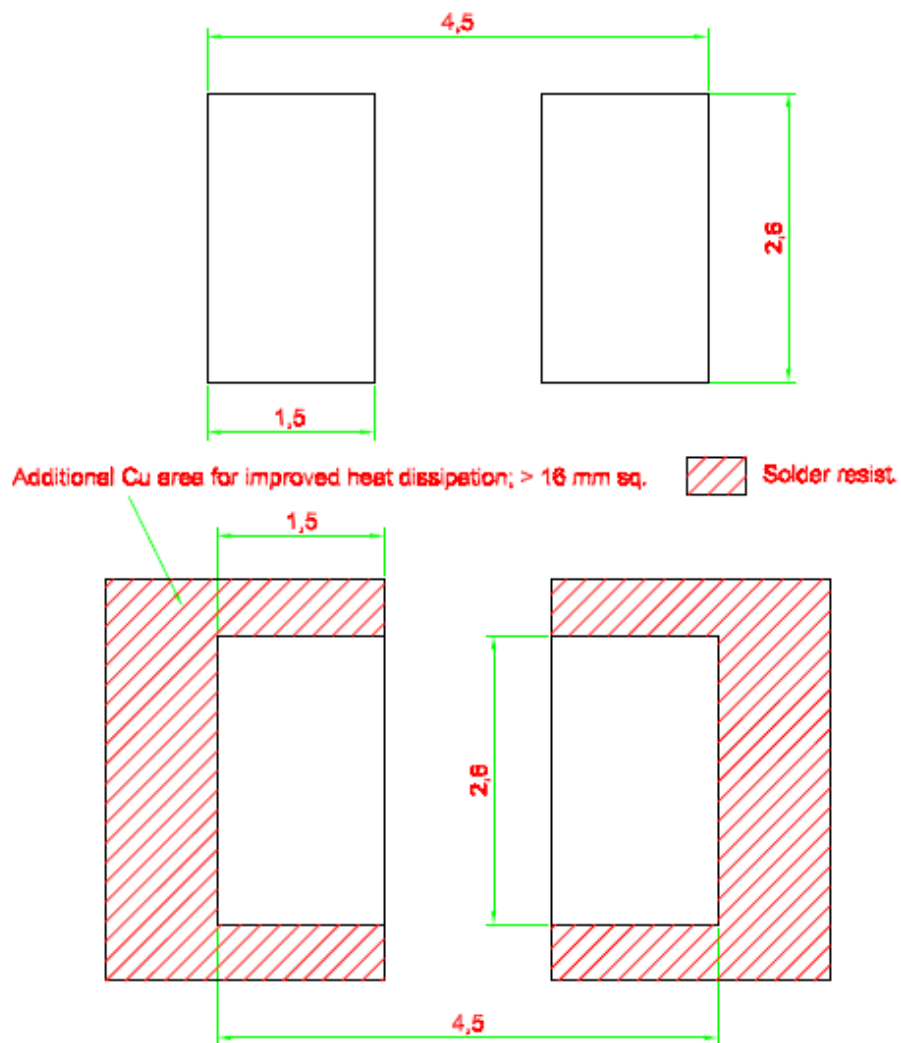

Engineering reference data are not verified. The specifications are subject to change without notice.

Relative intensity vs. forward current

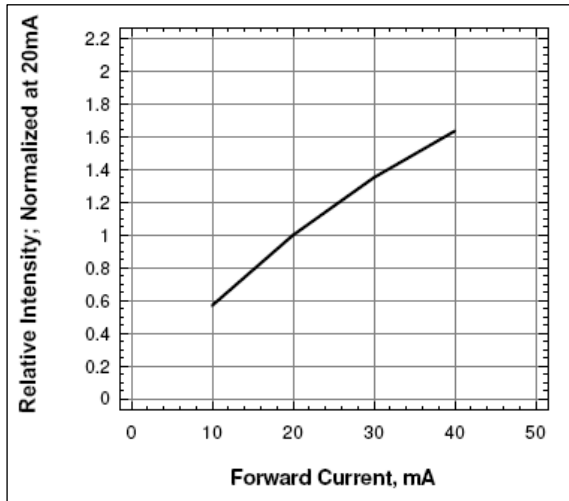

Forward voltage vs. forward current

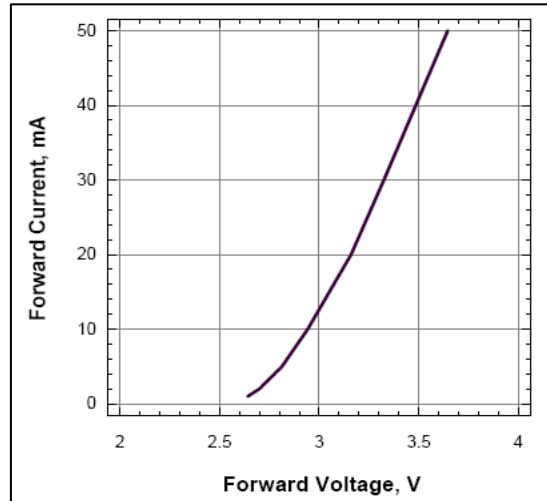

Radiation pattern.

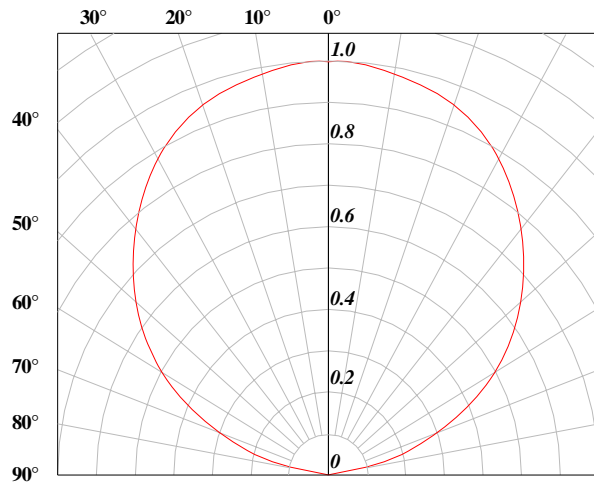

Color Spectrum

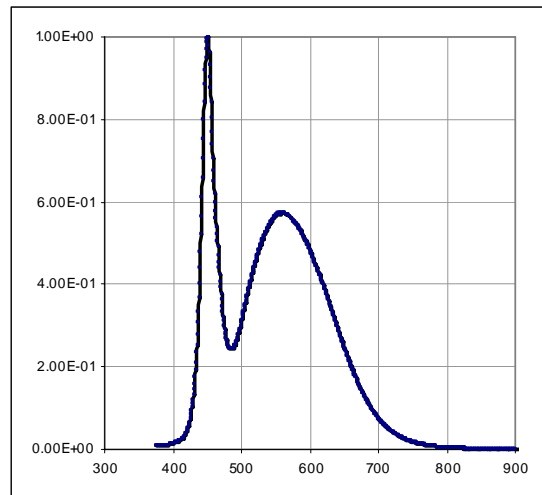

Maximum current vs. Ambient temperature.

TBD

Engineering reference data are not verified. The specifications are subject to change without notice.

Taping And Orientation.

Reels come in quantity of 2000 units.

Reel diameter is 180 mm.

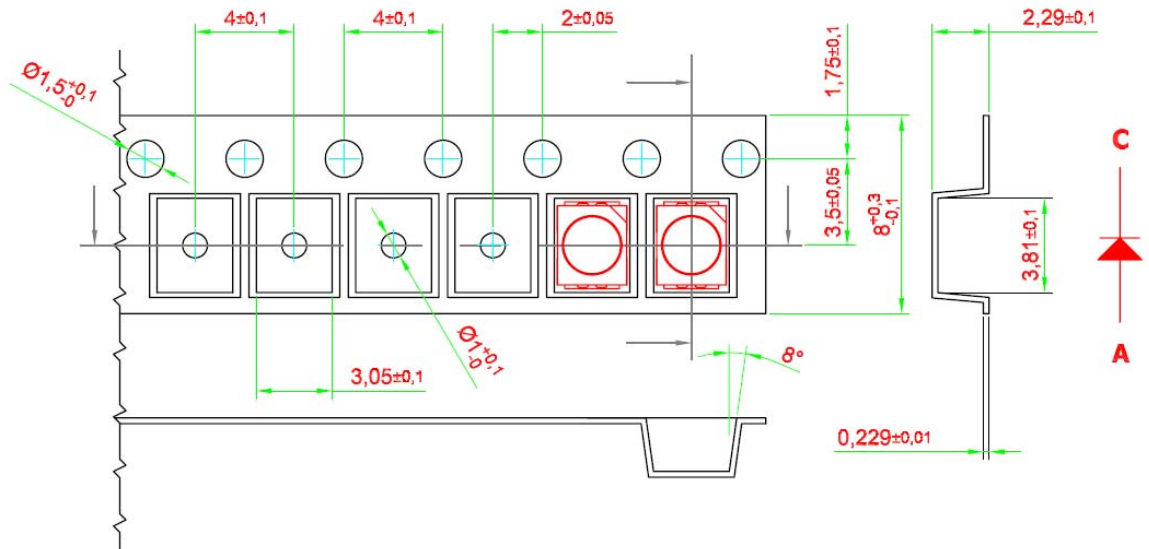

200 mm min. for Ø180 reel.

480 mm min. for Ø180 reel.

200 mm min. for Ø330 reel.

960 mm min. for Ø330 reel.

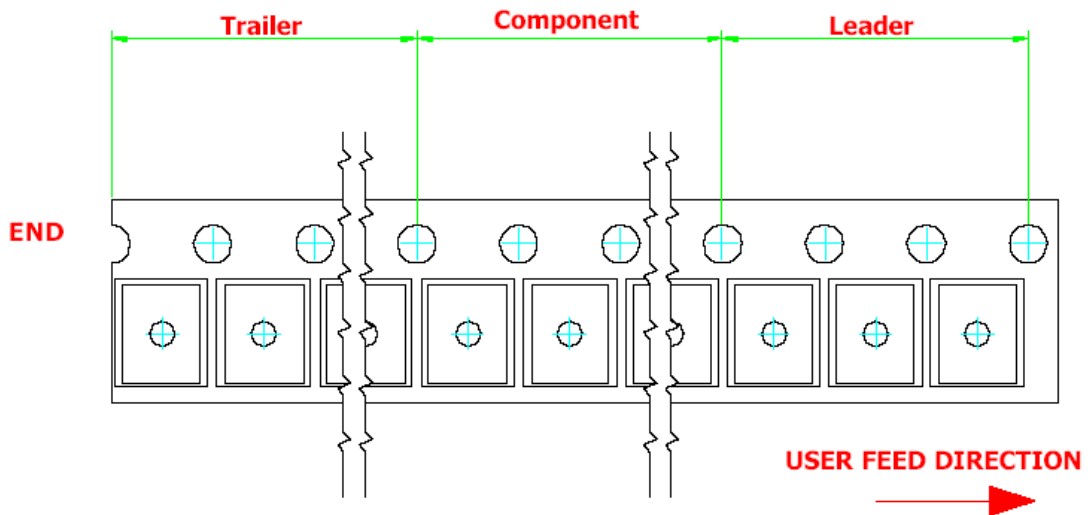

Engineering reference data are not verified. The specifications are subject to change without notice.

Recommended Sn-Pb IR-Reflow Soldering Profile.

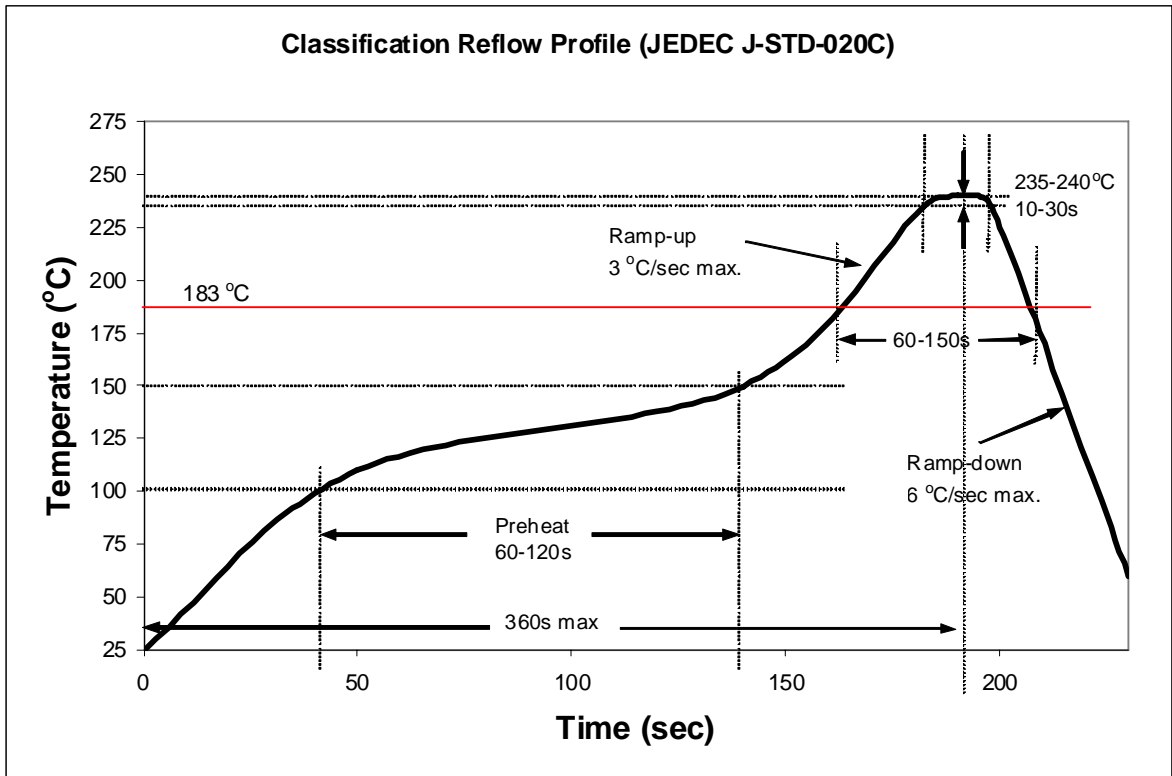

Recommended Pb Free IR-Reflow Soldering Profile.

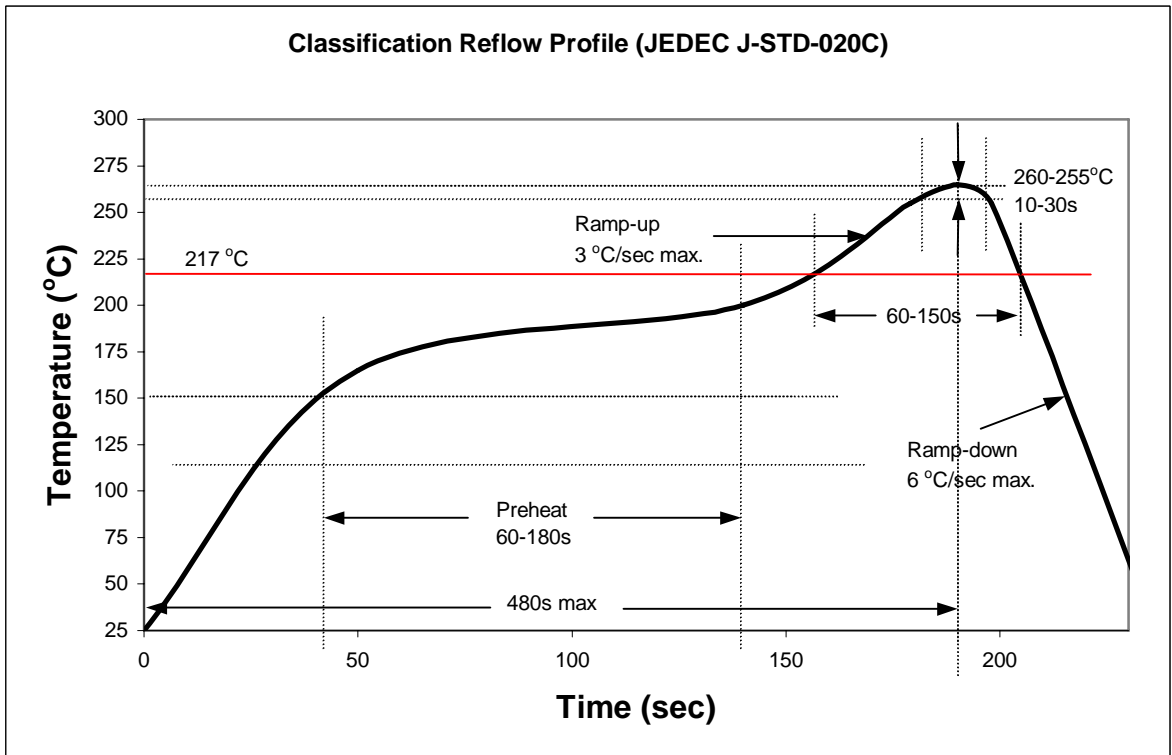

Engineering reference data are not verified. The specifications are subject to change without notice.

NOTE.

All the information published is considered to be reliable. However, DOMINANT Semiconductors does not assume any liability arising out of the application or use of any product described herein.

DOMINANT Semiconductors reserves the right to make changes at any time without notice to any products in order to improve reliability, function or design.

DOMINANT Semiconductors products are not authorized for use as critical components in life support devices or systems without the express written approval from the managing director of DOMINANT Semiconductors.