

F2500RU Series



4:1 Input 25W - 30W Single & Dual Output DC/DC Converters

Key Features:

- 25W-30W Output Power
- 4:1 Input Voltage Range
- 1,500 VDC Isolation
- Meets EN55022 Class A
- Compact 2 x 1.6 In. Case
- Single & Dual Outputs
- Remote ON/OFF
- Industry Standard Pin-Out



MicroPower Direct

292 Page Street
Suite D
Stoughton, MA 02072
USA

T: (781) 344-8226
F: (781) 344-8481
E: sales@micropowerdirect.com
W: www.micropowerdirect.com



Electrical Specifications

Specifications typical @ +25°C, nominal input voltage & rated output current, unless otherwise noted. Specifications subject to change without notice.

Input

Parameter	Conditions	Min.	Typ.	Max.	Units
Input Start Voltage	24 VDC Input	9.4	9.7	10.0	VDC
	48 VDC Input	17.0	17.5	18.0	
Under Voltage Shutdown	24 VDC Input	9.0	9.3	9.5	VDC
	48 VDC Input	16.0	16.5	17.0	
Input Filter	π (Pi) Filter (Meets EN55022 Class "A")				
Reverse Polarity Input Current				2.0	A
Short Circuit Input Power				4,500	mW

Output

Parameter	Conditions	Min.	Typ.	Max.	Units
Output Voltage Accuracy			±0.5	±1.0	%
Output Voltage Balance	Dual Output , Balanced Loads		±0.5	±2.0	%
Line Regulation	For Vin Min to Max		±0.2	±0.5	%
Load Regulation	I _{out} = 50% to 100%		±0.3	±1.0	%
Ripple & Noise (20 MHz) (Note 1)			55	80	mV P - P
Ripple & Noise (20 MHz)	Over Line, Load & Temp.			100	mV P - P
Ripple & Noise (20 MHz)				10	mV rms
Output Power Protection		120		180	%
Transient Recovery Time (Note 2)	25% Load Step Change		150	300	µSec
Transient Response Deviation			±2.0	±4.0	%
Temperature Coefficient			±0.01	±0.02	%/°C
Output Short Circuit	Continuous (Autorecovery)				

General

Parameter	Conditions	Min.	Typ.	Max.	Units
Isolation Voltage	60 Seconds	1,500			VDC
Isolation Voltage Test	Flash Tested For 1 Second	1,650			VDC
Isolation Resistance	500 VDC	1,000			MΩ
Isolation Capacitance	100 kHz, 1V		1,200	1,500	pF
Switching Frequency		290	330	360	kHz
Over Temperature Protection	Case Temperature	107	112	117	°C

Remote On/Off (Note 3)

Parameter	Conditions	Min.	Typ.	Max.	Units
Supply On		2.5		100.0	VDC
Supply Off		-1.0		1.0	VDC
Standby Input Current				5	mA
Control Common	Referenced to Negative Input (pin 2)				

Environmental

Parameter	Conditions	Min.	Typ.	Max.	Units
Operating Temperature Range	Ambient	-40		+50	°C
Operating Temperature Range	Case	-40		+105	°C
Storage Temperature Range		-50		+125	°C
Cooling	Free Air Convection				
Humidity	RH, Non-condensing			95	%

Physical

Case Size	2.0 x 1.6 x 0.37 Inches (50.8 x 40.6 x 9.3 mm)				
Case Material	Metal with Non-Conductive Base				
Weight	1.75 Oz (48g)				

Reliability Specifications

Parameter	Conditions	Min.	Typ.	Max.	Units
MTBF	MIL HDBK 217F, 25°C, Gnd Benign	1,000			kHours

Absolute Maximum Ratings

Parameter	Conditions	Min.	Typ.	Max.	Units
Input Voltage Surge (1 Sec)	24 VDC Input	-0.7		50.0	VDC
	48 VDC Input	-0.7		100.0	
Lead Temperature	1.5 mm From Case For 10 Sec			260	°C
Internal Power Dissipation	All Models			5,500	mW

Caution: Exceeding Absolute Maximum Ratings may damage the module. These are not continuous operating ratings.

Model Selection Guide

Model Number	Input				Output			Over Voltage Protection (VDC)	Efficiency (% Typ)	Capacitive Load (µF Max)	Fuse Rating Slow-Blow (mA)
	Voltage (VDC)		Current (mA)		Voltage (VDC)	Current (mA, Max)	Current (mA, Min)				
	Nominal	Range	Full-Load	No-Load							
F2501RU	24	10.0 - 40.0	922	20	3.3	5,500	400.0	3.9	82	1,000	5,000
F2502RU	24	10.0 - 40.0	1,225	20	5.0	5,000	350.0	6.8	85	1,000	5,000
F2503RU	24	10.0 - 40.0	1,404	20	12.0	2,500	166.0	15.0	89	1,000	5,000
F2504RU	24	10.0 - 40.0	1,404	20	15.0	2,000	133.0	18.0	89	1,000	5,000
F2505RU	24	10.0 - 40.0	1,404	20	±12.0	±1,250	±83.0	±15.0	89	±330	5,000
F2506RU	24	10.0 - 40.0	1,404	20	±15.0	±1,000	±65.0	±18.0	89	±330	5,000
F2511RU	48	18.0 - 75.0	461	10	3.3	5,500	400.0	3.9	82	1,000	3,000
F2512RU	48	18.0 - 75.0	613	10	5.0	5,000	350.0	6.8	85	1,000	3,000
F2513RU	48	18.0 - 75.0	702	10	12.0	2,500	166.0	15.0	89	1,000	3,000
F2514RU	48	18.0 - 75.0	702	10	15.0	2,000	133.0	18.0	89	1,000	3,000
F2515RU	48	18.0 - 75.0	702	10	±12.0	±1,250	±83.0	±15.0	89	±330	3,000
F2516RU	48	18.0 - 75.0	702	10	±15.0	±1,000	±65.0	±18.0	89	±330	3,000

Notes:

- When measuring output ripple, it is recommended that an external 1.0 µF ceramic capacitor be placed from the +Vout pin to the -Vout pin for single output units and from each output to common for dual output units. For noise sensitive applications, the use of 4.7 µF capacitors will reduce the output ripple.
- Transient recovery is measured to within a 1% error band for a load step change of 75% to 100%.
- The maximum sink current at the on/off pin (pin 4) during a logic low is 100 µA. The maximum allowable leakage current of a switch connected to the on/off pin (Pin 4) at logic high (2.5V to 100V) is 5 µA. If the on/off pin (Pin 4) is left open, the unit operates. If it is grounded, the unit will shut off.
- Operation at no-load will not damage these units. However, they may not meet all specifications.
- Dual output units may be connected to provide a 24 VDC or 30 VDC output. To do this, connect the load across the positive (+Vout) and negative (-Vout) outputs and float the output common.
- The converter should be connected to a low ac-impedance source. An input source with a highly inductive impedance may affect the stability of the converter. In applications where the converter output loading is high and input power is supplied over long lines, it may be necessary to use a capacitor on the input to insure start-up. In this case, it is recommended that a low Equivalent Series Resistance (ESR <1.0Ω at 100 kHz) capacitor be mounted close to the converter. A 33 µF is recommended for 24V input models and a 10 µF for 48V units.
- It is recommended that a fuse be used on the input of a power supply for protection. See the table above for the correct rating.

For Heatsink Option, add suffix "H" to model number (i.e. F2503RU-H)

Mechanical Dimensions

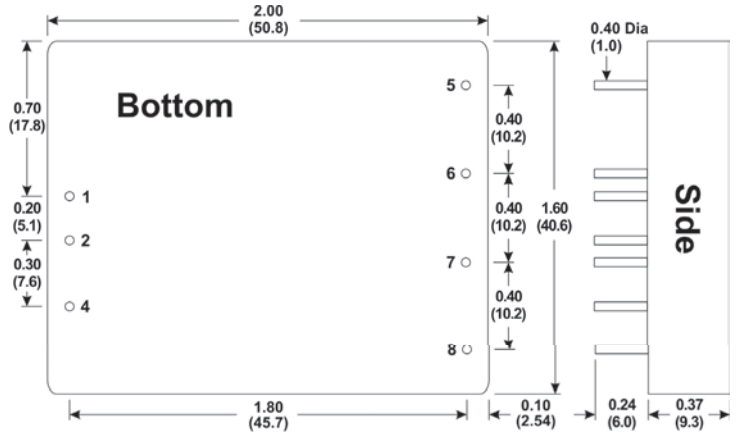

Pin Connections

Pin	Single	Dual	Pin	Single	Dual
1	+Vin	+Vin	6	+Vout	Comm.
2	-Vin	-Vin	7	-Vout	-Vout
4	ON/OFF	ON/OFF	8	Trim	Trim
5	No Pin	+Vout			

Mechanical Notes:

- All dimensions are typical in inches (mm)
- Tolerance x.xx = ±0.01 (±0.25)

Heatsink Dimensions (Optional)

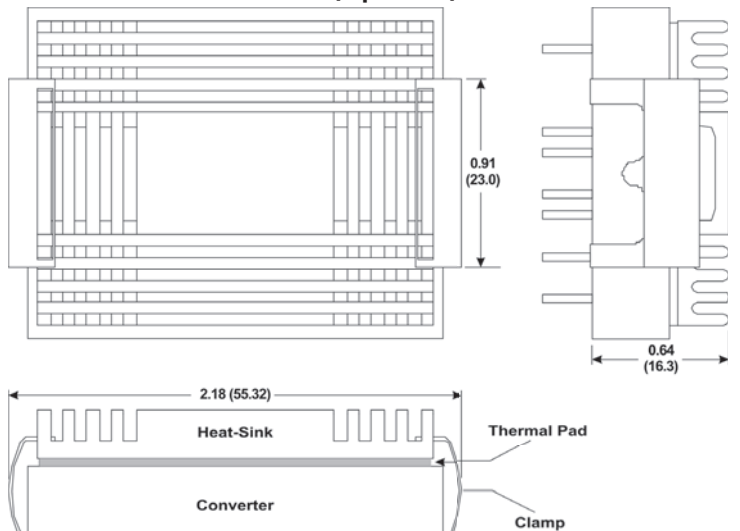

Heatsink Notes:

- Use of the heatsink will extend the units operating temperature range by approximately 10°C.
- The heatsink is black anodized aluminum.

External Trim

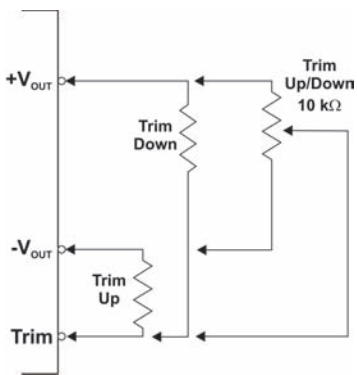

A simple external circuit may be used to adjust the converter output. To adjust the output DOWN, connect a 5%, 3W resistor between the plus output pin and the Vout trim pin. To adjust the output UP, connect a 5%, 3W resistor between the minus output pin and the Vout trim pin. To calculate the correct resistor value use:

$$\text{UP} \quad R_{adj} = \frac{(33 \times V_{out}) - (30 \times V_{adj})}{V_{adj} - V_{out}}$$

$$\text{Down} \quad R_{adj} = \frac{(36.667 \times V_{out}) - (33 \times V_{out})}{V_{out} - V_{adj}}$$

For UP/Down trimming capability, connect a 10 kW potentiometer between the plus and minus outputs with the wiper arm connected to the Vout trim pin.

Derating Curves

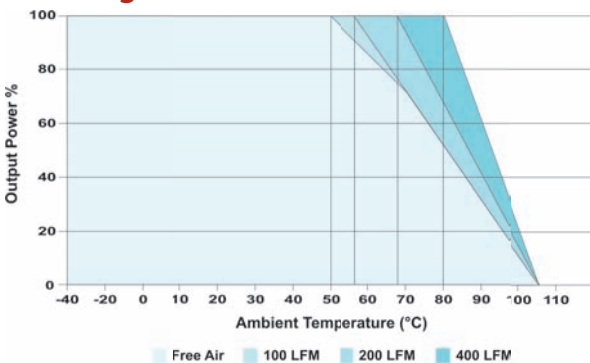

MicroPower Direct
www.micropowerelectronics.com