

# SR7810 Series

## Low Cost, 1A Output Non-isolated POL Switching Regulators



### Key Features:

- Efficiency to 96%
- 1A Output Current
- Compact SIP Case
- LM78xx Replacement
- Wide Input Range
- Short Circuit Protected
- Thermal Shutdown
- Low Noise
- **Low Low Cost**



### MicroPower Direct

292 Page Street  
Suite D  
Stoughton, MA 02072  
USA

T: (781) 344-8226  
F: (781) 344-8481  
E: sales@micropowerdirect.com  
W: www.micropowerdirect.com



### Electrical Specifications

Specifications typical @ +25°C, nominal input voltage & rated output current, unless otherwise noted. Specifications subject to change without notice.

#### Output

Parameter	Conditions	Min.	Typ.	Max.	Units
Output Voltage Accuracy			±2.0	±3.0	%
Line Regulation	V <sub>in</sub> = Min to Max		±0.2	±0.4	%
Load Regulation	I <sub>out</sub> = 10% to 100%		±0.4	±0.6	%
Ripple & Noise (20 MHz)			20	35	mV P - P
Dynamic Load Stability	See Note 1			±100	mV
Output Power Protection		120			%
Thermal Shutdown	See Note 2		150		°C
Quiescent Current, Note 3	Positive Output		5	8	mA
	Negative Output		7	13	
Temperature Coefficient				0.02	%/°C
Maximum Capacitive Load				1,000	µF
Output Current Limit				2,000	mA
Short Circuit Input Power			0.5	1.8	W
Output Short Circuit	Continuous (Autorecovery)				

#### General

Parameter	Conditions	Min.	Typ.	Max.	Units
Isolation Voltage	Not Isolated				
Switching Frequency		280	330	450	kHz

#### Environmental

Parameter	Conditions	Min.	Typ.	Max.	Units
Operating Temperature Range	Ambient	-40	+25	+85	°C
Operating Temperature Range	Case			+100	°C
Storage Temperature Range		-55		+125	°C
Lead Temperature	1.5 mm From Case For 10 Sec			300	°C
Cooling	Free Air Convection				
Humidity	RH, Non-condensing			95	%

#### Physical

Case Size	0.45 x 0.35 x 0.69 Inches (11.5 x 9.0 x 17.50 mm)				
Case Material	Non-Conductive Black Plastic (UL-94V0)				
Weight	0.13 Oz (3.7g)				

#### Reliability Specifications

Parameter	Conditions	Min.	Typ.	Max.	Units
MTBF	MIL HDBK 217F, 25°C, Gnd Benign	2.0			MHours

[www.micropowerdirect.com](http://www.micropowerdirect.com)

Model Number	Input Voltage Range (VDC)	Output		Efficiency (% Typ)	
		Voltage (VDC)	Current (mA, Max)	Min Vin	Max Vin
SR7810-03W	4.75 - 28.0	3.3	1,000.0	90	83
	4.75 - 25.0	-3.3	-600.0	80	82
SR7810-05W	6.5 - 32.0	5.0	1,000.0	93	88
	7.0 - 27.0	-5.0	-600.0	85	87
SR7810-06W	9.0 - 32.0	6.5	1,000.0	94	90
	7.0 - 25.0	-6.5	-400.0	88	90
SR7810-09W	12.0 - 32.0	9.0	1,000.0	95	92
	7.0 - 23.0	-9.0	-400.0	89	91
SR7810-12W	16.0 - 32.0	12.0	1,000.0	96	94
	7.0 - 32.0	-12.0	-300.0	89	91

Notes:

1. Dynamic load stability is specified for output loads from 10% to 100%.
2. Measured at an internal IC junction.
3. Quiescent current is specified at 0% load for Vin = min to max.
4. This regulator is not designed to be used in parallel with another unit to increase output power.
5. The input should not exceed the range given in the model selection chart. Exceeding this limit could damage the unit.

Derating Curve

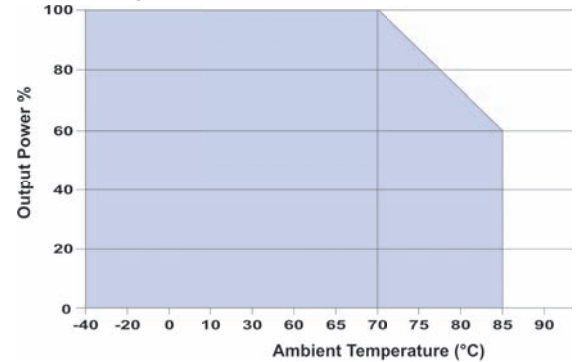

Typical Application Circuits

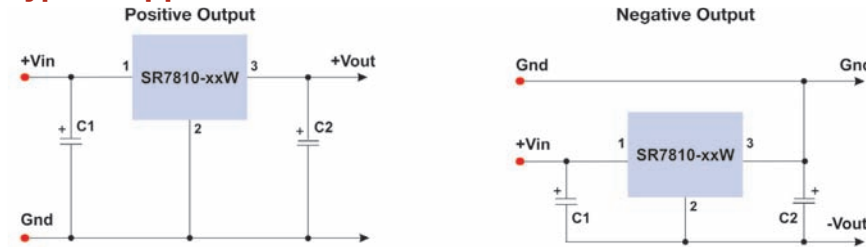

Pin Connection

Pin	1	2	3
Function	+Vin	Gnd	+Vout

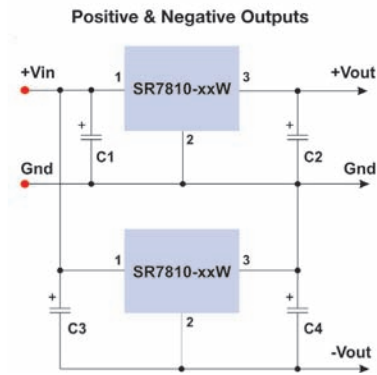

Component Values

Model Number	Ceramic Capacitors	
	C1, C3	C2, C4
SR7810-03W	10 $\mu$ F/50V	22 $\mu$ F/ 6.3V
SR7810-05W	10 $\mu$ F/50V	22 $\mu$ F/ 10V
SR7810-06W	10 $\mu$ F/50V	10 $\mu$ F/ 10V
SR7810-09W	10 $\mu$ F/50V	10 $\mu$ F/ 16V
SR7810-12W	10 $\mu$ F/50V	10 $\mu$ F/ 25V

Notes:

1. C1 & C3 are low ESR ceramic capacitors used to minimize noise at the regulator. A tantalum or low ESR electrolytic capacitor may also be used.
2. C1 & C2 (and if used C3 & C4) are required and should be mounted as close to the regulator pins as possible.

Mechanical Dimensions

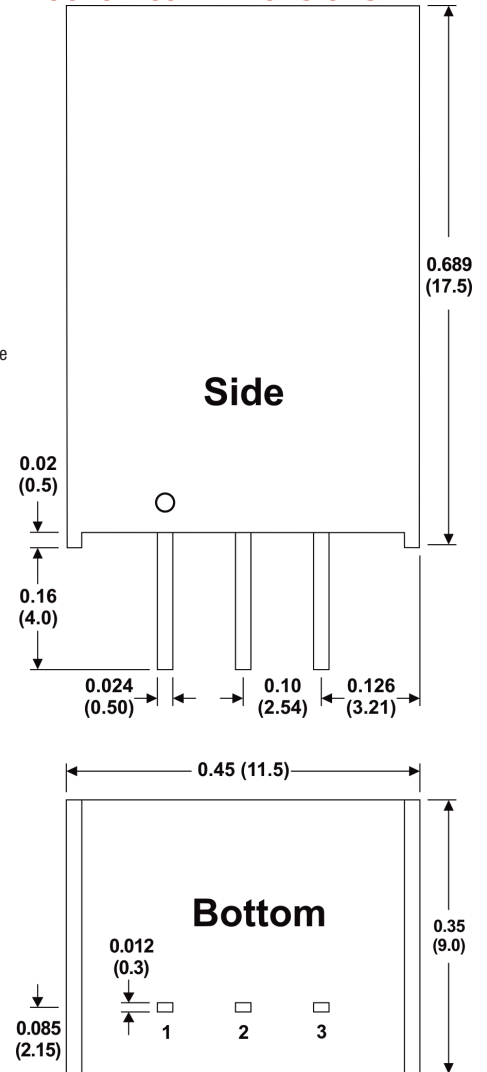

Characteristic Curves (Efficiency & Ripple)

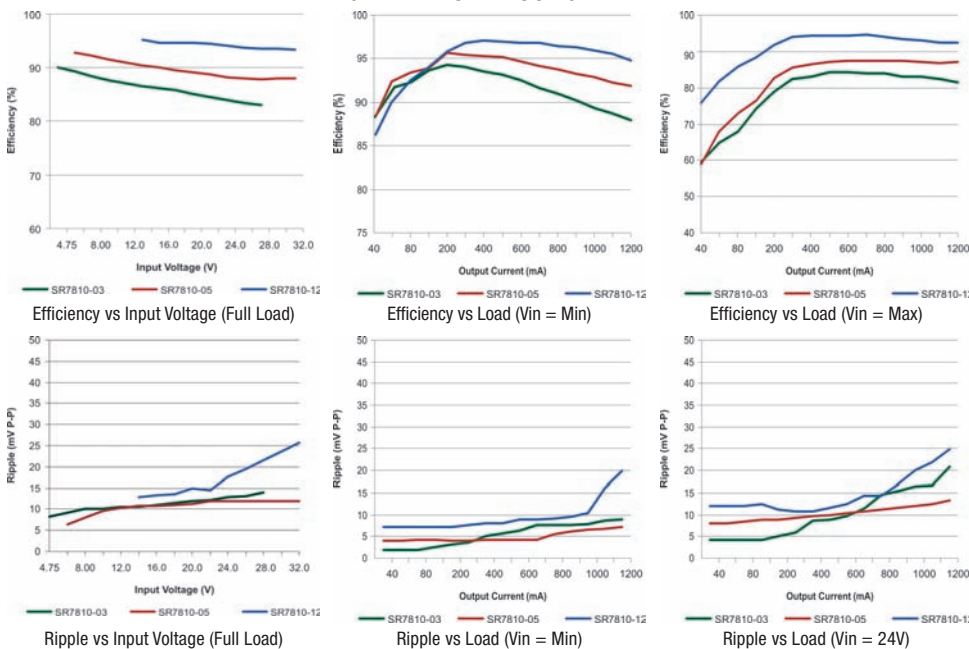

Notes:

- All dimensions are typical in inches (mm)
- Tolerance x.xx =  $\pm 0.01$  ( $\pm 0.25$ )
- Pin 1 is marked by a "dot" or indentation on the side of the unit