

Pixim D2000 Video Imaging System for Advanced CCTV Cameras

D2010

Digital Image Sensor

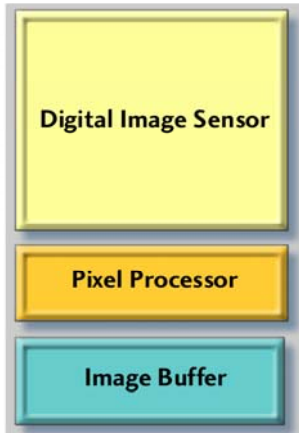

The Pixim D2000 Video Imaging System is a highly integrated two chip set utilizing Pixim's innovative new Digital Pixel System™ (DPS) technology that provides the image sensor and the necessary intelligence to develop advanced feature, high quality, cost-effective color CCTV cameras. The D2000 is designed to deliver superior quality video, providing up to 95 dB dynamic range in normal operation while providing excellent resolution, sensitivity and color fidelity. The D2000 includes configurable software which allows camera manufacturers to get to market quickly and offer a number of camera products from the same base hardware design, including an option to select PAL / NTSC operation via a jumper or switch. Simultaneous analog (composite, S-video, or component) and digital outputs are available.

For advanced applications that utilize additional processing or remote access, the D2000 offers an interface to an external processor. The chip set is manufactured in a high volume commercial 0.18 micron CMOS process, utilizing 1.8V operation for low power dissipation.

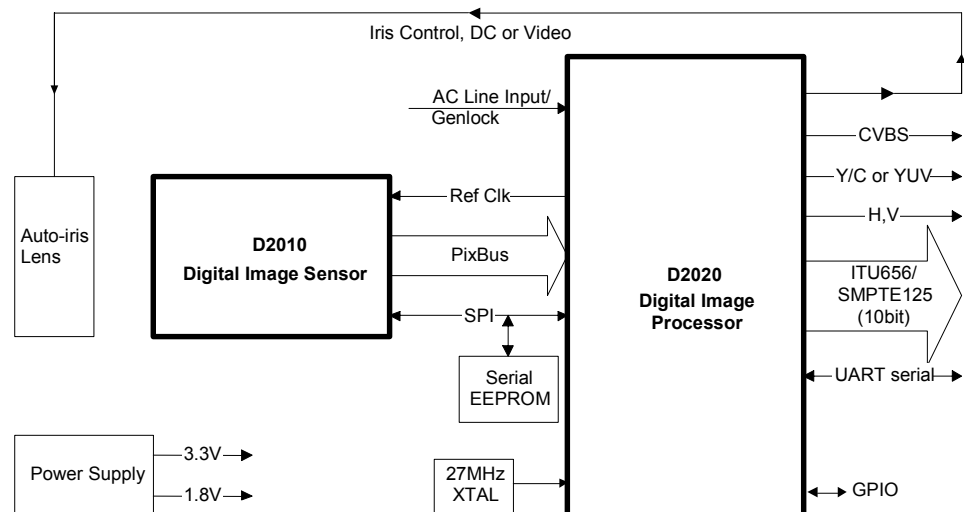

D2020

Digital Image Processor

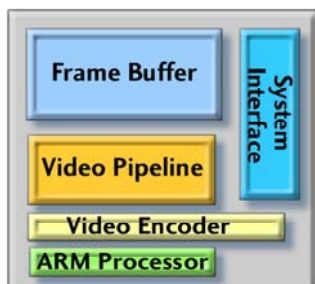

Highlights

High resolution color for crisp, clear video

Horizontal resolution: >480 TV
Vertical resolution: >400 TV Lines

High sensitivity for low-light images

Wide dynamic range provides excellent quality in high-contrast environments

95 dB (14-bit) typical
120 dB max.

Single design supports NTSC, PAL, and digital video

Analog: Composite, S-Video, YUV/RGB
Digital: 10-bit parallel digital video (ITU/BT656, SMPTE 125)

Automatic Exposure Mode for best pictures

Numerous Control Options

- Automatic White Balance
- Backlight compensation
- AC line lock, internal or external sync
- Automatic Gain Control
- On-screen display
- Activity / motion detection
- Electronic Iris
- Digital Pan / Tilt / Zoom
- Configurable alarms
- Auto-Iris control (DC, video)

Specifications

D2010 Digital Image Sensor

- Pixel type: DPS™ technology
- Silicon process: 0.18 μm CMOS
- Image size: diagonal 6.3 mm (Type 1/3")
- Sensor array size: 5.04mm (H) x 3.78 mm (V)
- Pixel size: 7 μm x 7 μm
- Picture elements: total: 742 (H) x 554 (V); effective: 720 (H) x 540 (V)
- Color filter array: complementary (CMY)
- Dynamic range: 95 dB typical, 120 dB max
- Resolution: >480 horizontal TV lines
- Minimal blooming
- Zero smear

D2020 Digital Image Processor

- Silicon process: 0.18 μm CMOS
- ARM™ processor core
- Custom image pipeline
- Built-in NTSC/PAL video encoder
- Extensive programmability
- Histogram engine
- DIP switch / push-button menu support
- Camera ID
- Alarms: on-screen, serial port, GPO, and zoom alarms
- White balance: auto tracking, manual, and presets
- Gamma correction options
- Electronic shutter
- Wide dynamic range
- Automatic gain control
- Backlight compensation control
- B/W mode
- Image flip: horizontal
- Digital Pan/Tilt/Zoom (1x to 4x zoom)
- Iris selection: DC type, video type, fixed Iris type
- Exposure control: electronic Iris; DC/Video auto iris lens support
- Auto iris output: Video or DC drive using internal PWM DAC

System Interfaces

- Boot EPROM: serial SPI
- Iris Control: control Video Iris lenses or DC Iris output
- CVBS: Composite video signal (75 Ω output)
- Y/C: standard S-video output (75 Ω output)
- YUV: component output (75 Ω output)
- External Sync: H, V TTL output
- Parallel video: ITU-R656 format 8-bit; SMPTE 125M 10-bit video (CCIR 601)
- UART: general purpose for configuration, alignment, and remote control
- GPIO: 12 general input/output pins for camera modes via DIP switches or push buttons

Power

- Standard 1.8V (core) and 3.3V (I/O) supply
- Typical power: 1.5 W for D2000 chip set
- Max. power: <2 W for D2000 chip set

Package

- D2010: 17mm x 17mm; 181 PBGA, 1mm ball pitch
- D2020: 15mm x 15mm; 144 PBGA, 1mm ball pitch

Temperature Range

- Operation: -10 to 60 degrees C ambient

System Tools

- Camera Development Kit (CDK)
- Pixim Manufacturing Application (PMA)

About DPS

Pixim's patented Digital Pixel System™ (DPS) technology marks a fundamental breakthrough in imaging technology. Building upon technology developed at Stanford University in the 1990s, Pixim has created an image capture and processing system that provides high-quality pictures with enhanced dynamic range. Greater dynamic range significantly improves image quality in scenes consisting of both bright and dark areas.

The core invention in DPS is the inclusion of an analog-to-digital converter (ADC) within each pixel of the image sensor. The ADC translates the light signal into a digital value at the immediate point of capture, thus minimizing signal degradation and cross-talk in the array and allowing for greater noise reduction methods. Once the data is captured in a digital format, a variety of digital signal processing techniques are used for optimal image reproduction.

As imaging technology continues to migrate toward totally digital systems, Pixim's Digital Pixel System technology will provide the foundation for image capture and image processing for the highest quality video and still cameras.