

PROTOCESSOR

OEM Industrial Protocol Modules

ProtoCessors are a family of low cost TTL to RS-232, RS-485, Ethernet and LonWorks Embedded Coprocessor modules. These allow OEM's to rapidly implement various Industrial, Building and Machine Automation protocols in their products.

In one stroke, adding a socket to the OEM's PCB increases sales of building, industrial or machine control products by ensuring compatibility with a broad range of serial and Ethernet protocols. At the same time costs are dramatically reduced by eliminating the need to install unused capacity where not required.

ProtoCessors also relieve engineering and marketing from committing to a single protocol and from having to maintain skills in multiple protocols. Now designers can take advantage of the extensive library of FieldServer Technologies' protocol drivers and they can be confident of their ability to support any future protocol.

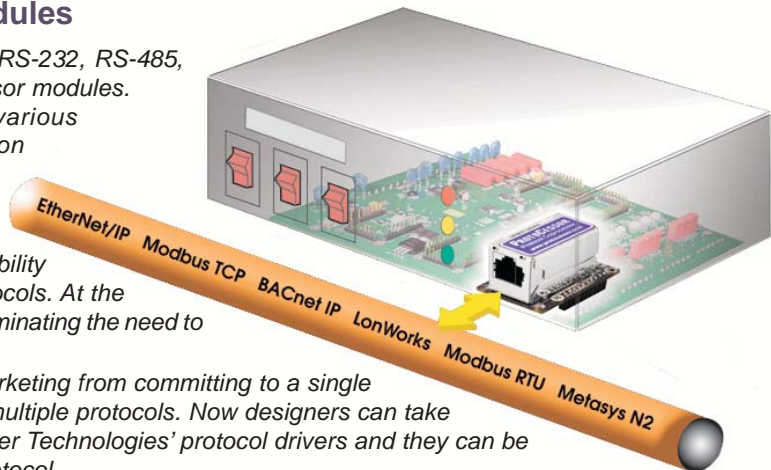

ProtoCessor Benefits

- **Increased Sales:** OEMs can offer many protocols that ProtoCessor provides with very little effort. Supporting these industry standard protocols will expand the markets for the OEMs in building, industrial or machine controller applications.
- **Reduced Costs:** ProtoCessors only need to be installed where necessary, avoiding delivery of unnecessary capability and cost.
- **Dramatically reduced NRE:** No costly purchase of source code and/or significant engineering time required. All required source code and hardware is provided.
- **Rapid Time-to-Market:** Minimal coding and hardware demands or changes to current OEM design required.
- **Minimal Impact to application hardware and software design:** A single socket needs to be added to the OEM's Design. ProtoCessor is compatible with 8/16/32 bit Microcontrollers. Once the single interface to the ProtoCessor family has been added, the OEM can use any field protocol module.
- **No need to develop and maintain in-house protocol support services:** This can be very costly and time consuming. No need to reinvent the wheel. FieldServer Technologies has many decades of experience developing their proven protocols. FieldServer has an extensive knowledge base and technical resources to provide complete support for any protocol need.
- **Compliance "built-in":** Full protocol compliance is assured through continuous testing and certification of the protocols through the various governing groups that set the standards.

ProtoCessor Supported Protocols

OEM's Host Processor Serial Communications	Serial Field Protocols	Ethernet Field Protocols	LonWorks	Profibus	ZigBee
Modbus RTU BACnet MSTP Metasys N2 Open ProtoCessor PCP or ProtoCessor PSP Your own custom Serial Driver *	Allen Bradley DF1 BACnet MSTP BACnet PTP J-Bus Modbus ASCII Modbus Daniels Modbus Omnicflow Modbus RTU Modbus Tek-Air Metasys N2 Open	Modbus TCP BACnet/IP BACnet EtherNet EtherNet/IP Allen Bradley CSP DNP3 GE-SRTP GE-EGD Omron SNMP	Available	Q2 2006	Q3 2006

Choose any of the protocols in the first column to act as the interface between the Host System and the ProtoCessor. Then, choose a protocol in the subsequent columns to be supported by your equipment.

*Small NRE to port custom host protocol to the ProtoCessor.

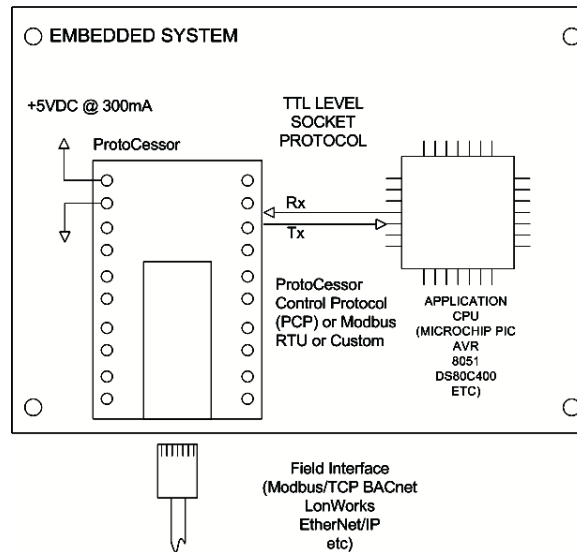

Full Function and Application Specific Families

Full function ProtoCessors (FFPs) are flexible, customer or field configurable. Application Specific ProtoCessors (ASPs) allow fixed designs to be customized for volume applications where the configuration does not change.

	FFP	ASP
Configuration	Fully configurable via downloadable file or by Host CPU via PCP driver.	Hard-coded configuration involving NRE, fixed configuration for mass produced, lower cost applications.
CPU	32 bit ARM-7 CPU	Microchip PIC
Program memory	2 MB	48 KB
RAM	8 MB	2 KB
PCP driver supports configuration	Yes (Complex binary PCP protocol)	No (Easy ASCII PSP protocol)
PCP driver mode	Client	Server
PCP driver provides data transfer	Yes	Yes
Downloadable configuration	Yes – over Ethernet	No
Remote diagnostics	Full	Minimal
Multiple simultaneous drivers	Yes	No
Ethernet configuration port always included	Yes	No
Cost per unit	Higher	Lower, but with NRE upfront
Point count	1000's	100s, < 1000 depending on protocol

A Rapid Development Kit (RDK) is available for quick and easy implementation. This includes a ProtoCessor Development board, two ProtoCessor modules, documentation and technical support. The RDK can be loaded with any of the supported host and field protocols for immediate "out the box" protocol testing and evaluation.

Connections:

Field Connections

RS-232 DB9 Male
RS-485 3 way Phoenix connector
Ethernet: RJ-45 (8-pin)

Host connections

Standard Serial TTL Interface-TX and RX
Socket on Board: 20-pin

Power consumption:

FFP 5Vdc @ 300 mA
ASP 5Vdc @ 260 mA

Dimensions

ASP-485 L0.70 x W1.20
FFP-485 L2.70 x W1.20
FFP/ASP-ETH L1.80 x W1.0

Temperature:

Ambient: -40° - 185°F (-40° - 85°C)
Storage: -40° - 257°F (-40° - 125°C)
Humidity: 5 - 90% RH