



Expanding Wireless Horizons

RS9110-N-11-28: 802.11ABGN SELF-CONTAINED MODULE WITH NETWORKING STACK

The RS9110-N-11-28 module from Redpine's Connect-io-n™ family of products is a complete dual band (2.4/5GHz) IEEE 802.11abgn based wireless device server that directly provides a wireless interface to any equipment with a serial or SPI interface for data transfer. It integrates a MAC, Baseband processor, dual band RF transceiver with power amplifier and diplexer; and all WLAN protocol and configuration functionality, networking stack, and HTTP server in embedded firmware to make a dual band 802.11n WLAN solution for a variety of applications. No WLAN, configuration or networking functionality is required on the host system or data source. Based on Redpine Signals' RS9110 SoC that includes an embedded processor, it is designed to provide standards compliant wireless connectivity with enterprise-level security to devices and systems such as industrial equipment, medical electronic systems, POS equipment, sensor networks and metering equipment, M2M communications, and remote configuration applications. As a wireless serial modem, the RS9110-N-11-28 originates and terminates TCP and UDP connections, enabling a variety of M2M applications at low cost and small footprint. It uniquely provides connectivity in the single stream 802.11n mode, preserving overall network throughput in the emerging enterprise environments.



Features

- Compliant to 802.11a/b/g and single stream 802.11n
- 2.4/5 GHz, 802.11n RF transceiver with power amplifier
- Antenna selection diversity – choice of antenna for transmission and reception; or possibility of providing for separate antennas for 2.4 GHz and 5 GHz bands
- Highly integrated 2.4 GHz/5 GHz transceiver with direct conversion architecture
- Fully self-contained serial-to-wireless functionality - does not require any host processor bandwidth
- Includes all the protocol and configuration functions required for
- WLAN connectivity in open, WPA/WPA2-PSK, and WPA/WPA2-Enterprise modes of operation
- Payload data through Serial Interface and SPI
- Terminates TCP and UDP connections, and offers transparent serial modem functionality
- Configuration through UART or wireless means
- Bluetooth Coexistence support
- Ultra low power operation with power save modes
- Ad-hoc and infrastructure modes for maximum deployment flexibility
- Single supply 3.1 to 3.6 V operation

Applications

- Seamless Wi-Fi connectivity for any equipment with a serial or SPI interface
- Industrial M2M communications
- Point of Sale Terminals
- Metering
- Security Cameras & Surveillance Equipment
- Warehousing
- Digital Picture Frames
- Logistics and Freight Management
- Several Medical Applications including Patient Monitoring, Remote Diagnostics etc.

Specifications

Network Standard Support	IEEE 802.11a/b/g/n/h/i/j
Data Rates	802.11n: 6.5, 13, 19.5, 26, 39, 52, 58.5, 65 Mbps 802.11g: 6, 9, 12, 18, 24, 36, 48, 54 Mbps 802.11b: 1, 2, 5.5, 11 Mbps
Frequency Band	2.412 - 2.484 GHz (Low Band) 4.900 – 5.850 GHz (High band)
Modulation Techniques	OFDM with BPSK, QPSK, 16-QAM, and 64-QAM 802.11b with CCK and DSSS
QoS	WMM and WMM Power Save Support
Wireless Security	802.11i: AES, TKIP, WEP, WPA, and WPA2
802.11n Features	MCS 0-7, STBC, RIFS, Greenfield Protection, A-MPDU, A-MSDU Aggregation with Block-ack, PSMP, MTBA
Host Interfaces	SPI, UART
NetworkProtocols	TCP, HTTP Client/Server, ARP, UDP, IPv4, DHCP Client
WLAN Functions	Power save modes, automatic roaming, Ad-hoc and Infrastructure modes
Supported UART baud rates	Supports standard baud rates from 9600bps to 3.6Mbps
Configuration	AT commands (for UART)
Operating Temperature	Industrial Grade -40°C to +85°C
Supply Voltage	3.1 - 3.6 V
Dimensions	20 mm x 17.5 mm

Evaluation Package

Redpine Signals provides a comprehensive evaluation package that includes a board with the module mounted on it, along with standard serial connector, UART level shifters, frequency reference, antenna and 5 V power supply connection. It also includes a Windows XP GUI based configuration utility and software upgrade capability, along with detailed documentation.

RS9110-N-11-28 DIAGRAM

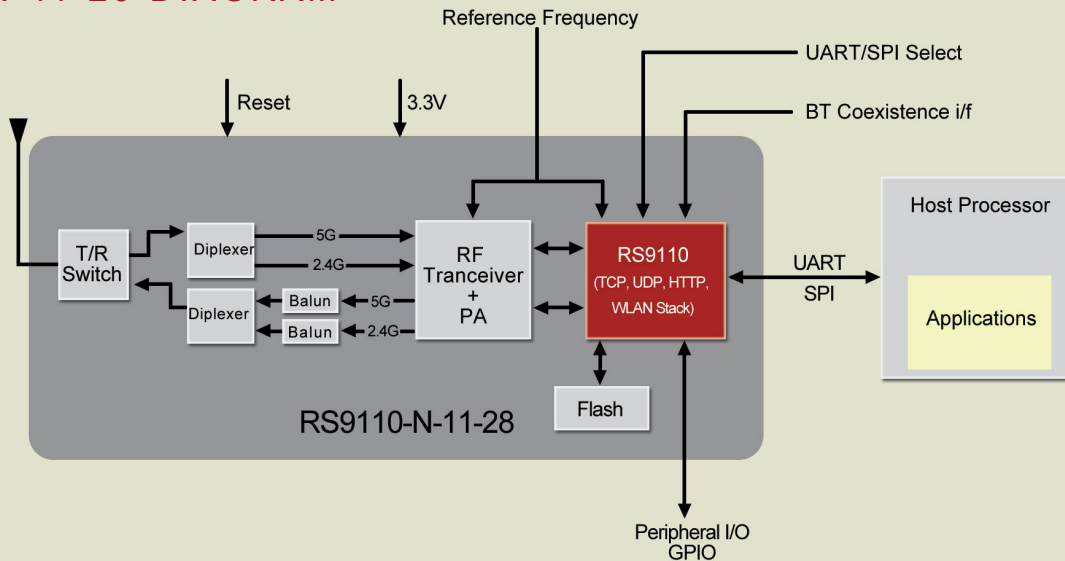

For additional information, please contact Sales at Redpine Signals, Inc.:

Redpine Signals, Inc. • 2107 North First Street • Suite 680 • San Jose, CA 95131

Phone: +1 408 748 3385 • Email: sales@redpinesignals.com

www.redpinesignals.com

Redpine Signals, Inc. reserves the right to make changes to the product(s) or information contained herein without notice. No Liability is assumed as a result of their use or application. Redpine, Redpine Signals, the Redpine logo, Expanding Wireless Horizons and Lite-Fi are trademarks of Redpine Signals, Inc. All other company names, products and logos are registered trademarks of their respective companies.

© Copyright 2008 Redpine Signals, Inc. All Rights Reserved

Connect-io-nTM
Wi-Fi® I/O for Microcontrollers