

Sine wave output filter with a voltage dc link

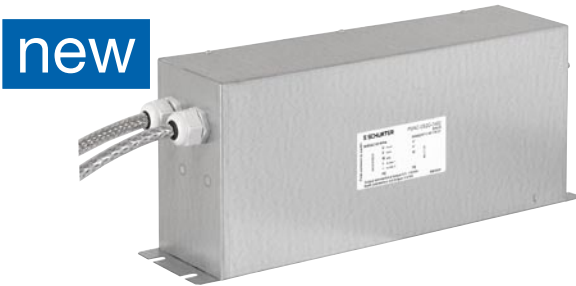

Description

- Design corresponding to UL 1283, CSA 22.2 No. 8, IEC/EN60939
- Enhancement of the system efficiency

Applications

- Optimized for long motor cables (up to 1000 m) and operation under full load
- Equipped with voltage connection to converter dc link circuit for best results
- Frequency converters in uninterruptible power supplies, elevators, heating-, ventilating- and air conditioning-systems, traction and conveyer systems
- Cost saving technologie, increase of motor life time, deployment of flexible lightweight unshielded instead of expensive shielded motor cables, reduced fitting work

References

[General Product Information](#)

Weblinks

[Approvals](#), [RoHS](#), [CHINA-RoHS](#), [Distributor-Stock-Check](#)

Technical Data

Rated Current	4 - 16A @ Ta 40 °C
Rated voltage	500/288 VAC; 50/60 Hz
Approval for	4 - 16A @ Ta °C / 500/288 VAC; 50Hz
Overload Current	1.5 x Ir for 1 minute, per hour
Dielectric Strength for 480 VAC	2.5 kVDC between L-L
	1.1 kVDC between L-PE
	Test voltage (2 sec)
Weight	16 - 24 kg
Material: Housing	Metal
Sealing Compound	UL 94V-2

Mounting	Screw-on mounting on chassis, from top
Terminal	Screw Clamp
Operating Temperature [°C]	-25 °C to 100 °C
Climatic Category	25/100/21 acc. to IEC 60068-1
Degree of Protection	IP 20 acc. to IEC 60529
Protection Class	Suitable for appliances with protection class 1 acc. to IEC 61140

Dimensions

Case 2G

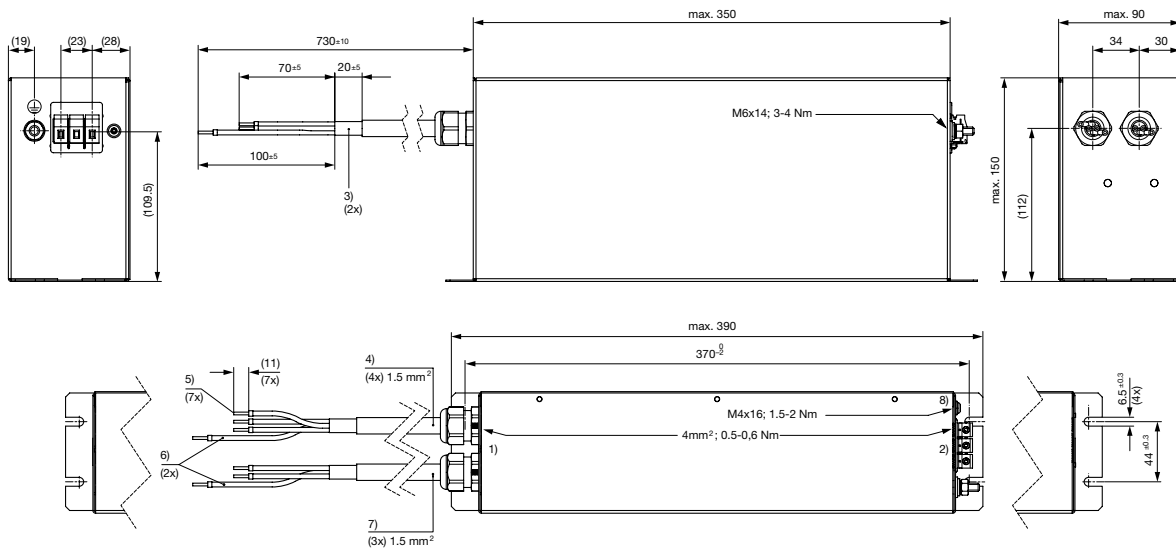

- 1) Inverter 2) Motor 3) Shield
 4) Shielded cable 5) Endsleeves
 6) Ground 7) Shielded cable 8) Operation Mode

Case IB

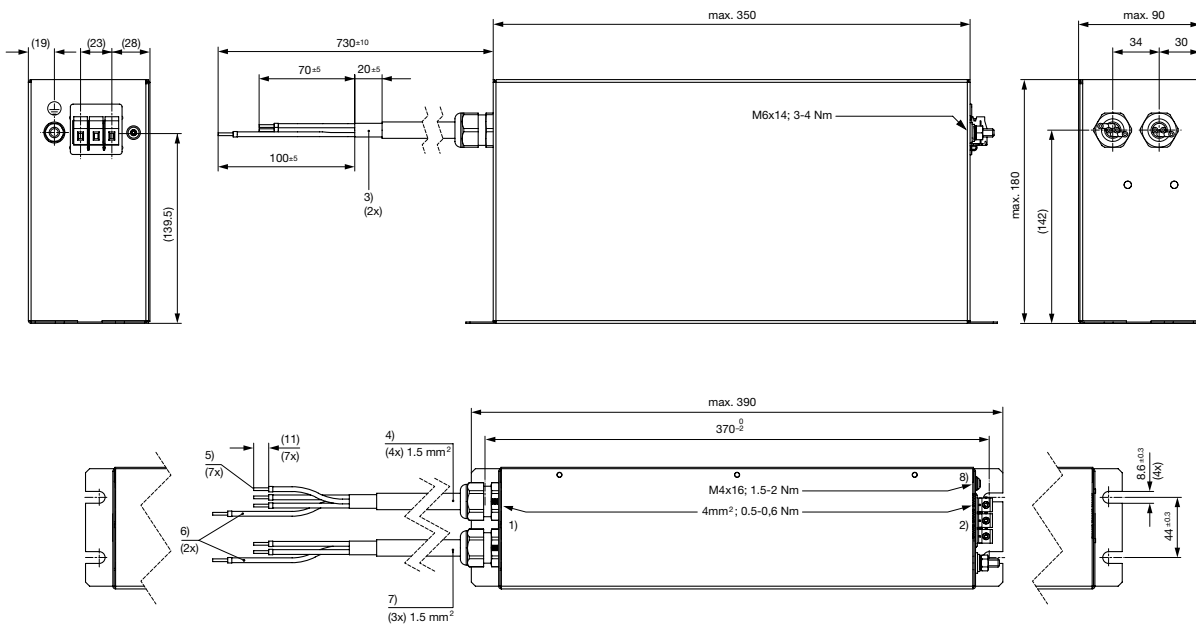

- 1) Inverter 2) Motor 3) Shield
 4) Shielded cable 5) Endsleeves
 6) Ground 7) Shielded cable 8) Operation Mode

Case 2H

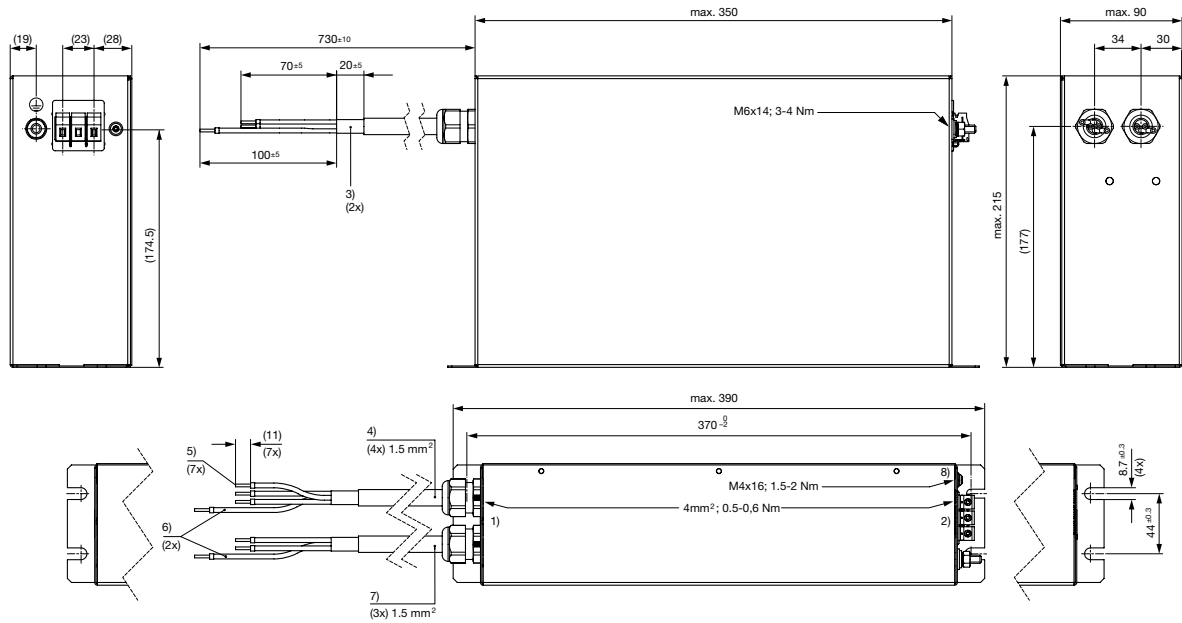

- 1) Inverter 2) Motor 3) Shield
- 4) Shielded cable 5) Endsleeves
- 6) Ground 7) Shielded cable 8) Operation Mode

Case 2I

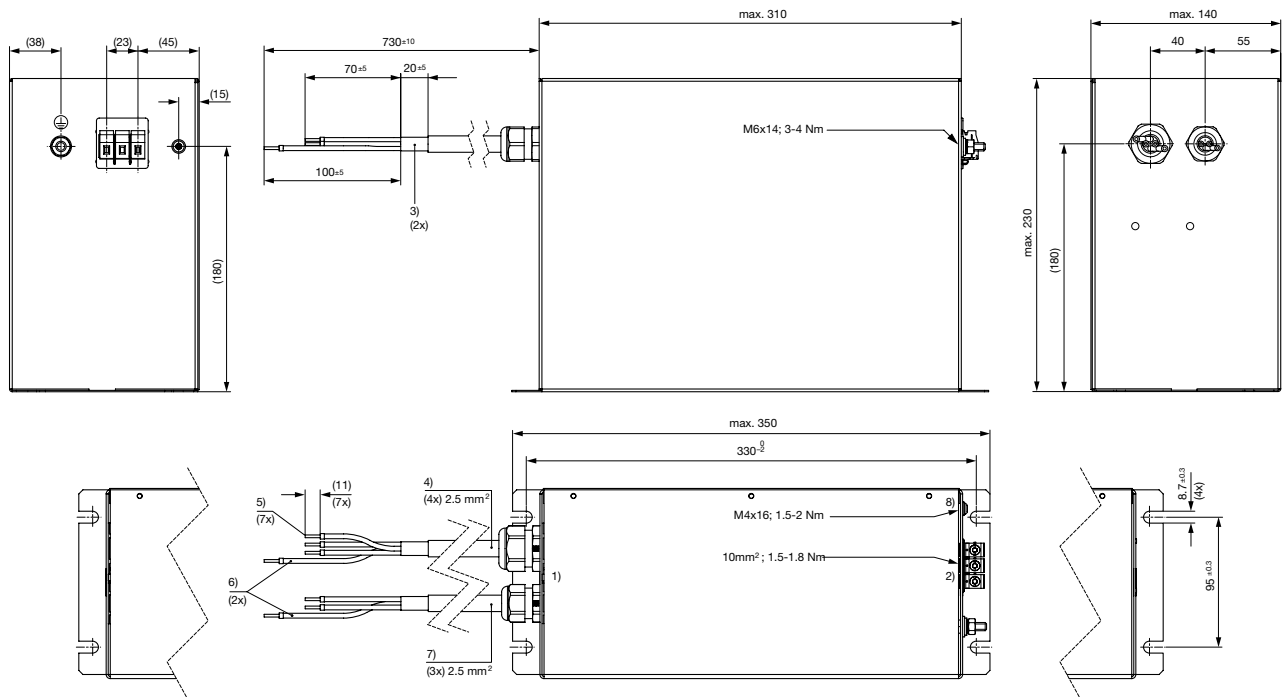

- 1) Inverter 2) Motor 3) Shield
- 4) Shielded cable 5) Endsleeves
- 6) Ground 7) Shielded cable 8) Operation Mode

Diagrams

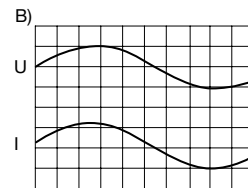
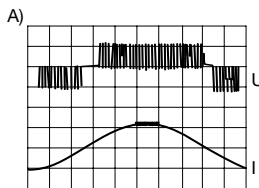
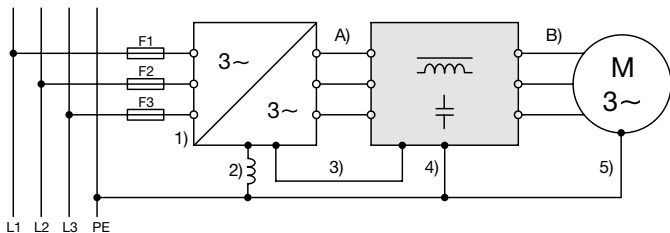

Note:

The inverter switching frequency must lie within the range from 2 to 20kHz. A switching frequency below or above the mentioned range will result in poor performances. Sine wave output filters with dc-link produce leakage currents. These leakage currents could, in combination with certain OEM inverter types, disturb overall system performance, causing a "over current or short to earth" error message on the inverter. For such cases Schurter suggests the following three solutions or a combination of each:

- 1) Increasing the switching frequency of the inverter (drawback: increased power loss in the inverter)
- 2) Activating the low leakage sine wave output filter operation mode by removing the factory set detachable screw (drawback: light increase of the leakage current in the motor)
- 3) Connecting a ground wire choke type DEH in the inverters earth connection (drawback: additional component)

1) Inverter 2) Ground choke 3) DC-Link 4) Sine wave output filter 5) Motor

Variants

Rated Current	Rated voltage	Switching frequency	Motor frequency	Rated motor power	Motor cable length	DC resistance	Total power loss	Weight	Housing	Order Number
[A]	[VAC]	[kHz]	[kHz]	[kW]	[m]	[mΩ]	[W]	[kg]		
8	500/288	2...20	0...200	3.0	<= 1000	220	14	16	1B	FMAC-0S1B-0862
4	500/288	2...20	0...200	1.5	<= 1000	450	8	13	2G	FMAC-0S2G-0462
12	500/288	2...20	0...200	5.5	<= 1000	140	20	20	2H	FMAC-0S2H-1262
16	500/288	2...20	0...200	7.5	<= 1000	110	28	24	2I	FMAC-0S2I-1662

Packaging unit 1 Pcs