



Pb Free

# Specification

## SSC-LCW100Z1

Preliminary  
(Rev 1.3 - SSC)

SSC		Customer
Drawn	Approval	Approval

SSC-LCW100Z1

Revision 1.3

www.ZLED.com

# [ Contents ]

1. **Absolute maximum ratings**
2. **Electro-optical characteristics**
3. **Electro-Optical characteristic diagram**
4. **Outline dimension**
5. **Recommended pad design**
6. **Binning and labeling**
7. **Packing**
8. **Reel packing structure**
9. **Soldering profile**
10. **Precaution for use**
11. **Order code**

# SSC-LCW100Z1

## Description

- Small size suitable for compact appliances.
- Surface-mounted chip LED device.
- Pb-free and RoHS complaint component.
- High brightness, High efficiency
- Tape and Reel packing.
- Increases the life time of battery.



## SSC-LCW100Z1

## Features

- 3.5 X 2.8 X 1.6 mm
- Emitted Color : White
- CIE chromaticity
  - x : 0.32      y : 0.32
  - x : 0.37      y : 0.37
  - x : 0.44      y : 0.41

Material : InGaN

## Applications

- Array lighting
- Other decoration lighting
- Information Boards
- Lighting for Small Size Device.

SSC-LCW100Z1

Revision 1.3

www.ZLED.com

## A. Pure White

### 1. Absolute maximum ratings

(Ta=25°C)

Parameter	Symbol	Value	Unit
Power Dissipation	$P_d$	175	mW
Forward Current	$I_F$	50	mA
Peak Forward Current	$I_{FM}^{*1}$	100	mA
ESD Sensitivity	HBM	10,000	V
Operation Temperature	$T_{opr.}$	-30 ~ 95	°C
Storage Temperature	$T_{stg.}$	-40 ~ 100	°C
Junction Temperature	$T_j$	125	°C

\*1  $I_{FM}$  conditions: Pulse width  $T_w \leq 0.1ms$  and Duty ratio  $\leq 1/10$ .

### 2. Electro-Optical Characteristics

(Ta=25°C)

Parameter-	Symbol	Condition	Min	Typ	Max	Unit
Forward Voltage	$V_F$	$I_F=20\text{ mA}$	-	3.15	-	V
Color Temperature	CCT	$I_F=20\text{ mA}$	-	6300	-	K
Luminous Flux*2	$\Phi_v$	$I_F=20\text{ mA}$	-	6.6	-	lm
Chromaticity Coordination	X	$I_F=20\text{ mA}$	-	0.32	-	-
	y		-	0.32	-	
CRI	Ra			68		
Viewing Angle*3	$2\theta_{1/2}$	$I_F=20\text{ mA}$	-	120	-	°
Thermal Resistance	$R\theta_{(J-C)}$	-	33			°C/W

\*2  $\Phi_v$  is total luminous flux output as measured with an integrating sphere.

\*3  $\theta_{1/2}$  is the off-axis where the luminous intensity is 1/2 the peak intensity.

[Note] All products confirm to the listed minimum and maximum specifications for electric and optical characteristics, when operated at 20mA within the maximum ratings shown above. All measurements were made under the standardized environment of SSC.

(Tolerance :  $I_v \pm 10\%$ , color coordinate 0.01,  $V_F \pm 0.1\text{ V}$ )

SSC-LCW100Z1

Revision 1.3

www.ZLED.com

## B. Warm White

### 1. Absolute maximum ratings

(Ta=25°C)

Parameter	Symbol	Value	Unit
Power Dissipation	$P_d$	175	mW
Forward Current	$I_F$	50	mA
Peak Forward Current	$I_{FM}^{*1}$	100	mA
ESD Sensitivity	HBM	10,000	V
Operation Temperature	$T_{opr.}$	-30 ~ 95	°C
Storage Temperature	$T_{stg.}$	-40 ~ 100	°C
Junction Temperature	$T_j$	125	°C

\*1  $I_{FM}$  conditions: Pulse width  $T_w \leq 0.1ms$  and Duty ratio  $\leq 1/10$ .

### 2. Electro-Optical Characteristics

(Ta=25°C)

Parameter-	Symbol	Condition	Min	Typ	Max	Unit
Forward Voltage	$V_F$	$I_F=20\text{ mA}$	-	3.15	-	V
Color Temperature	CCT	$I_F=20\text{ mA}$	-	3000	-	K
Luminous Flux*2	$\Phi_v$	$I_F=20\text{ mA}$	-	4.7	-	lm
Chromaticity Coordination	X	$I_F=20\text{ mA}$	-	0.44	-	-
	y		-	0.41	-	
CRI	Ra			90		
Viewing Angle*3	$2\theta_{1/2}$	$I_F=20\text{ mA}$	-	120	-	°
Thermal Resistance	$R\theta_{(J-C)}$	-	33			°C/W

\*2  $\Phi_v$  is total luminous flux output as measured with an integrating sphere.

\*3  $\theta_{1/2}$  is the off-axis where the luminous intensity is 1/2 the peak intensity.

[Note] All products confirm to the listed minimum and maximum specifications for electric and optical characteristics, when operated at 20mA within the maximum ratings shown above. All measurements were made under the standardized environment of SSC.

(Tolerance :  $I_v \pm 10\%$ , color coordinate 0.01,  $V_F \pm 0.1\text{ V}$ )

SSC-LCW100Z1

Revision 1.3

[www.ZLED.com](http://www.ZLED.com)

서식번호 : SSC-QP-7-07-25 (Rev.0.0)

## C. Natural White

### 1. Absolute maximum ratings

(Ta=25°C)

Parameter	Symbol	Value	Unit
Power Dissipation	$P_d$	175	mW
Forward Current	$I_F$	50	mA
Peak Forward Current	$I_{FM}^{*1}$	100	mA
ESD Sensitivity	HBM	10,000	V
Operation Temperature	$T_{opr.}$	-30 ~ 95	°C
Storage Temperature	$T_{stg.}$	-40 ~ 100	°C
Junction Temperature	$T_j$	125	°C

\*1  $I_{FM}$  conditions: Pulse width  $T_w \leq 0.1ms$  and Duty ratio  $\leq 1/10$ .

### 2. Electro-Optical Characteristics

(Ta=25°C)

Parameter-	Symbol	Condition	Min	Typ	Max	Unit
Forward Voltage	$V_F$	$I_F=20\text{ mA}$	-	3.15	-	V
Color Temperature	CCT	$I_F=20\text{ mA}$	-	4300	-	K
Luminous Flux*2	$\Phi_v$	$I_F=20\text{ mA}$	-	5.3	-	lm
Chromaticity Coordination	X	$I_F=20\text{ mA}$	-	0.37	-	-
	y		-	0.37	-	
CRI	Ra			85		
Viewing Angle*3	$2\theta_{1/2}$	$I_F=20\text{ mA}$	-	120	-	°
Thermal Resistance	$R\theta_{(J-C)}$	-	33			°C/W

\*2  $\Phi_v$  is total luminous flux output as measured with an integrating sphere.

\*3  $\theta_{1/2}$  is the off-axis where the luminous intensity is 1/2 the peak intensity.

[Note] All products confirm to the listed minimum and maximum specifications for electric and optical characteristics, when operated at 20mA within the maximum ratings shown above. All measurements were made under the standardized environment of SSC.

(Tolerance :  $I_v \pm 10\%$ , color coordinate 0.01,  $V_F \pm 0.1\text{ V}$ )

SSC-LCW100Z1

Revision 1.3

www.ZLED.com

### 3. Electro-Optical Characteristic Diagram

Ta = 25°

Forward Current vs. Forward Voltage

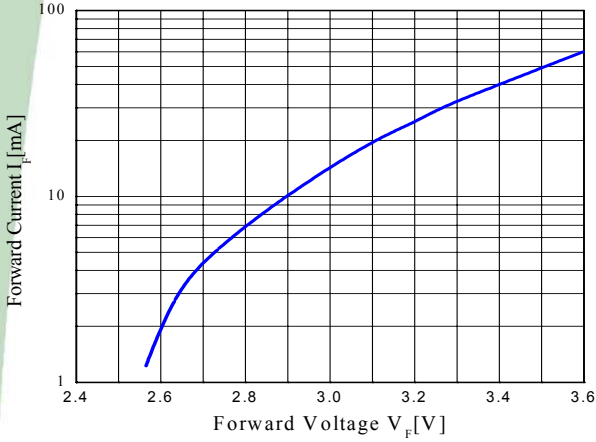

Relative Luminous Flux vs. Forward Current

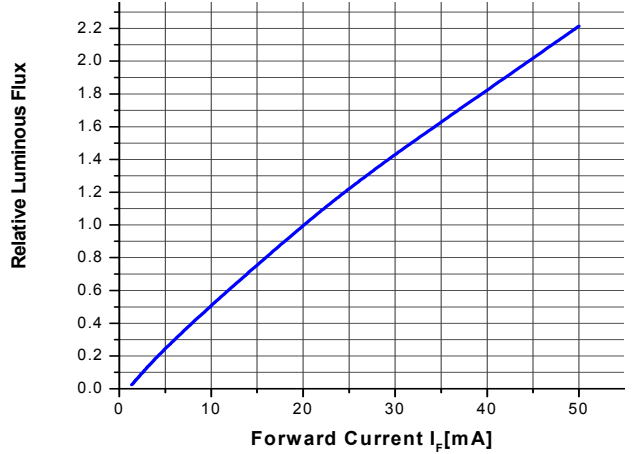

Relative Light Output vs. Junction Temperature at IF=20mA

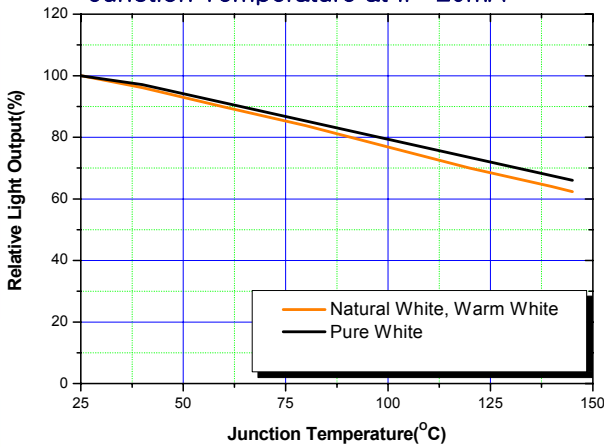

Ambient Temperature vs Allowable Forward Current

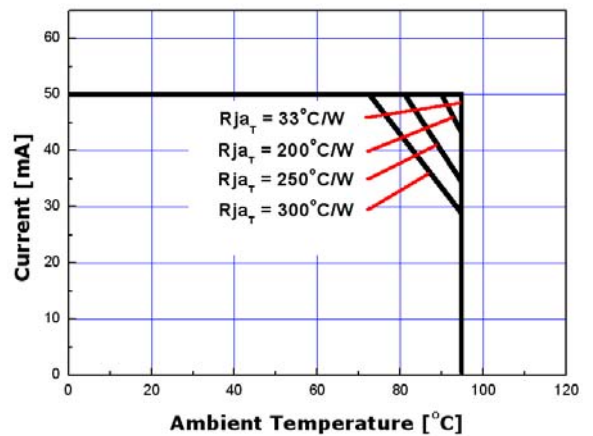

Radiation Diagram

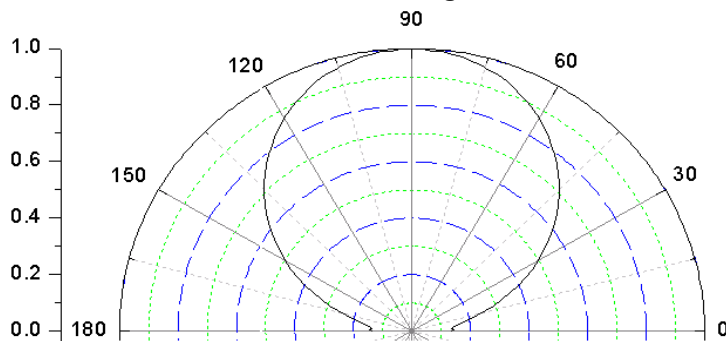

SSC-LCW100Z1

Revision 1.3

www.ZLED.com

Spectrum Distribution

1. Pure White

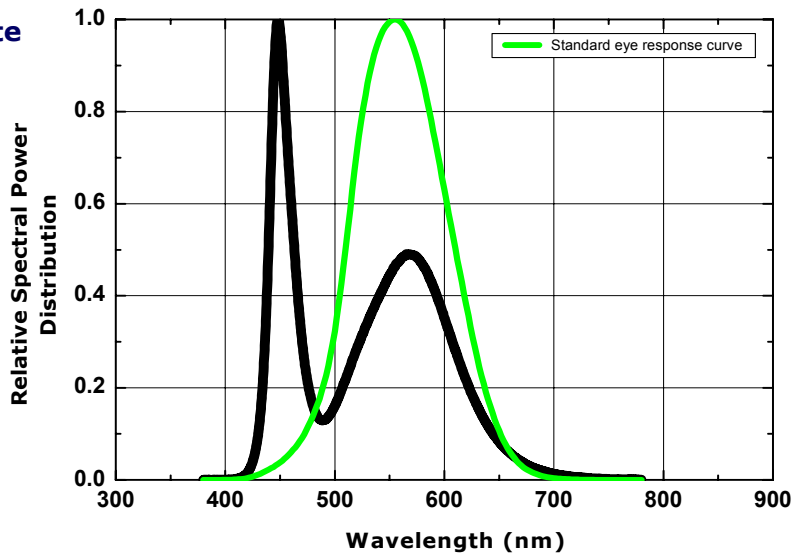

2. Warm White

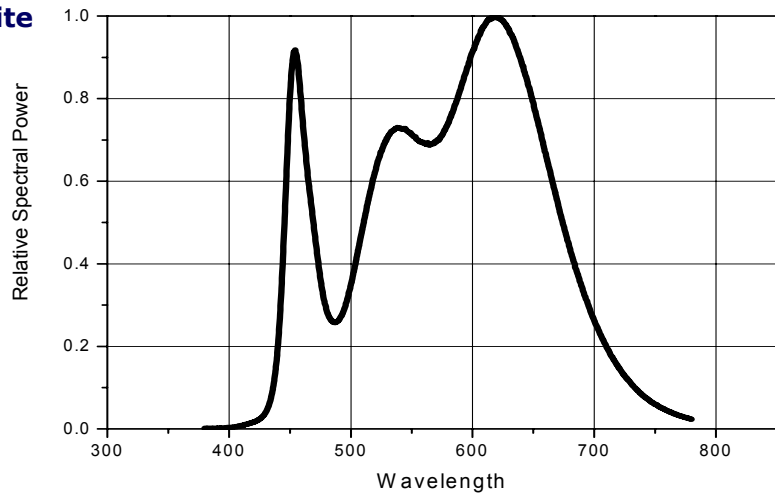

3. Natural White

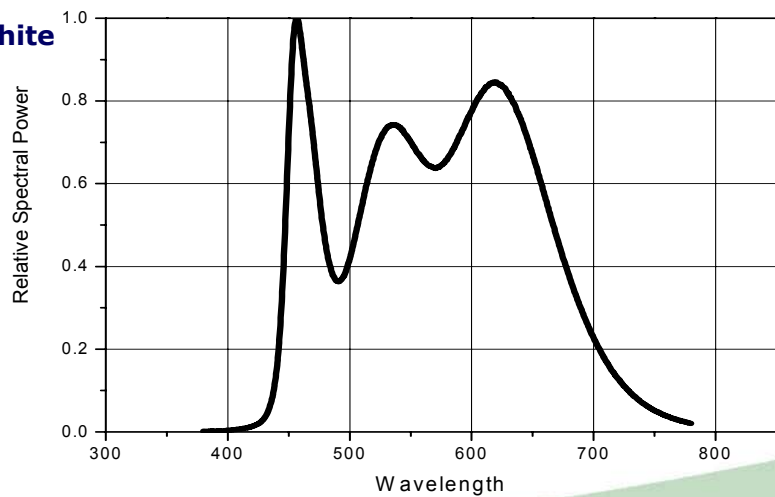

### 4. Outline Dimension

Tolerance:  $\pm 0.1$ , Unit: mm

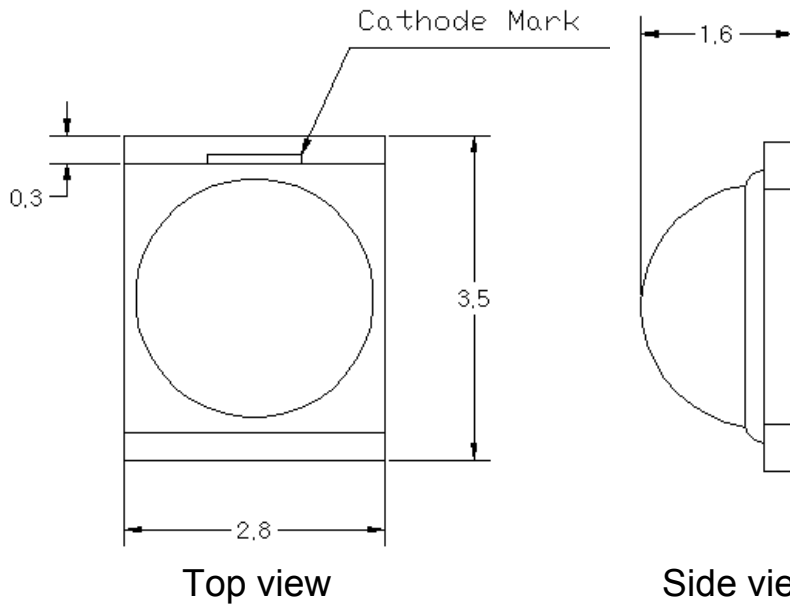

### Circuit Diagram

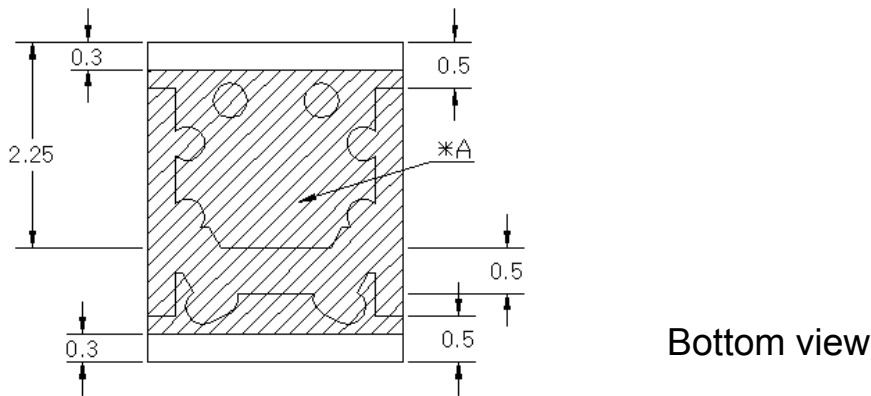
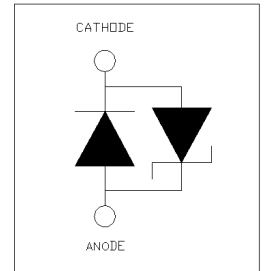

\*A : This area can be covered with thin resin.

### 5. Recommended Soldering Design

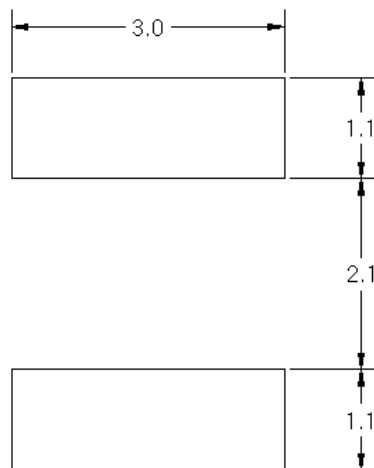

SSC-LCW100Z1

Revision 1.3

www.ZLED.com

## 6. Binning & Labeling

### (1) Luminous Flux: LF [lm]

Rank	LF [lm]	Condition
A	4.0~5.0	20mA
B	5.0~6.0	
C	6.0~7.0	
D	7.0~8.0	

### (2) Color Coordinates: x, y

Rank	CIE-X	CIE-Y	CCT [K]	Rank	CIE-X	CIE-Y	CCT [K]
A	0.3205	0.3481	6500	E	0.4007	0.4043	4000
	0.3028	0.3304			0.3737	0.3875	
	0.3068	0.3113			0.3671	0.3580	
	0.3221	0.3261			0.3900	0.3718	
B	0.3376	0.3616	5700	F	0.4298	0.4163	3500
	0.3207	0.3462			0.3998	0.4015	
	0.3222	0.3243			0.3892	0.3695	
	0.3366	0.3369			0.4150	0.3816	
C	0.3551	0.3760	5000	G	0.4560	0.4260	3000
	0.3376	0.3616			0.4298	0.4163	
	0.3366	0.3369			0.4150	0.3816	
	0.3515	0.3487			0.4377	0.3896	
D	0.3737	0.3875	4500	H	0.4812	0.4318	2700
	0.3549	0.3743			0.4560	0.4260	
	0.3513	0.3471			0.4377	0.3896	
	0.3671	0.3580			0.4595	0.3942	

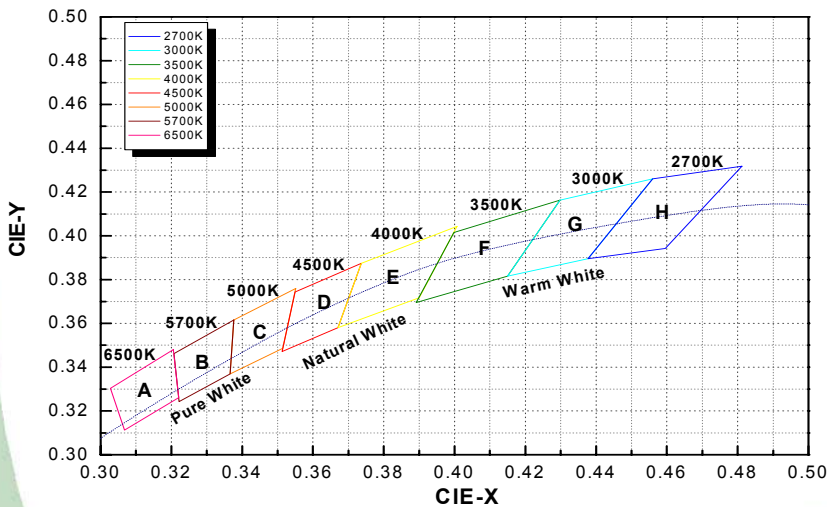

(3) Forward Voltage:  $V_F$  [V]

Rank	$V_F$ [V]	Condition
A	2.70~2.95	20mA
B	2.95~3.20	
C	3.20~3.45	
D	3.45~3.70	

(4) Labeling

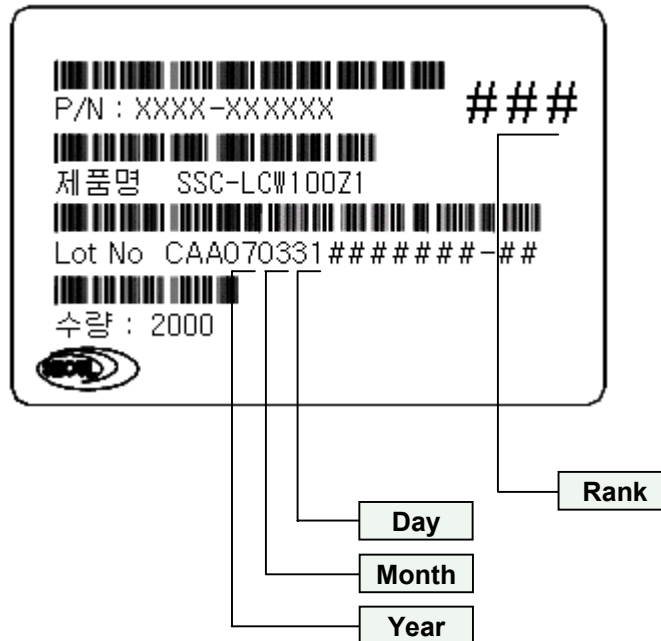

(5) Rank

#1 #2 #3

- #1 : LuminousFlux: LF [lm]
- #2 : Color Coordinates: x, y
- #3 : Forward Voltage:  $V_F$  [V]

### 7. Packing

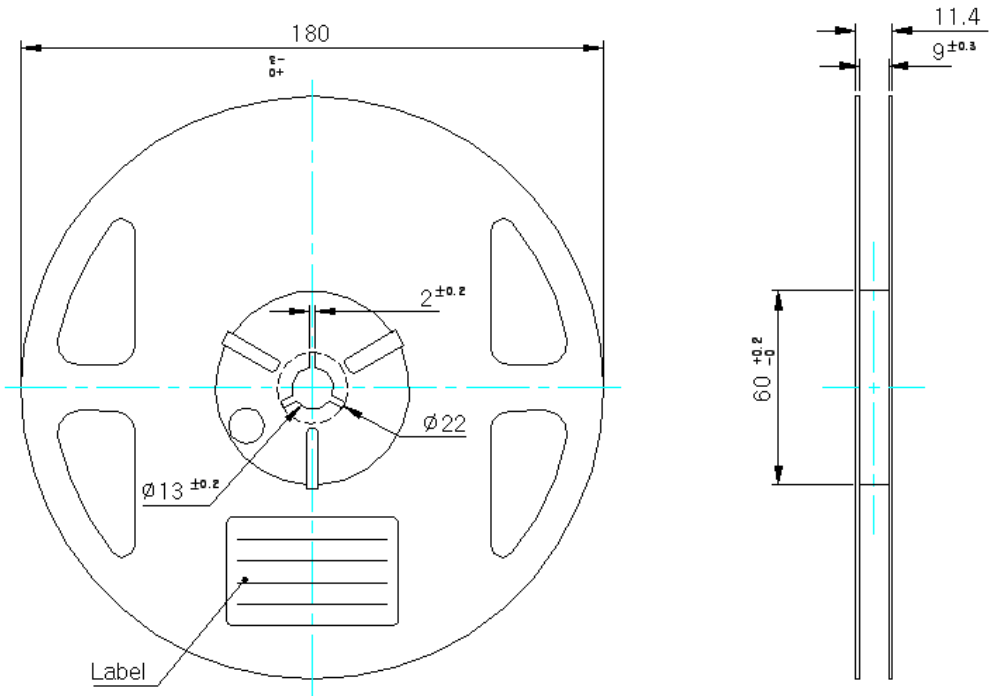
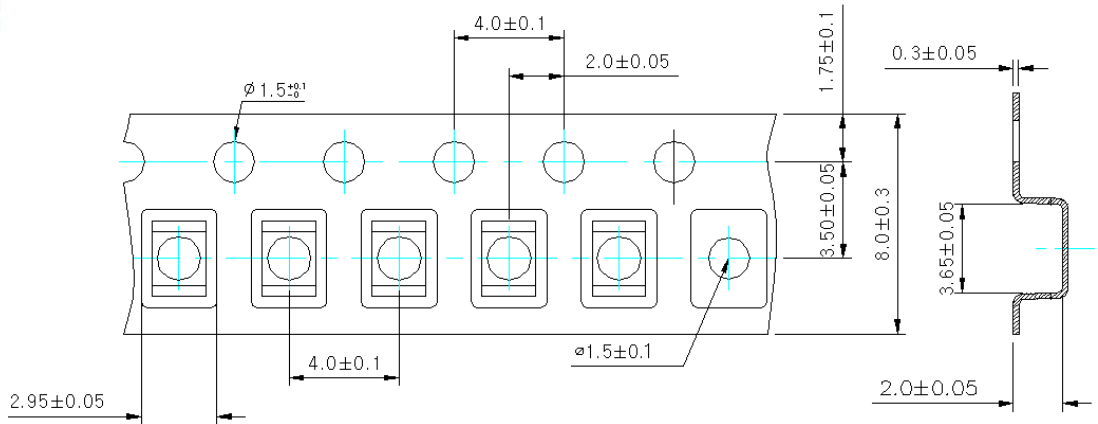

Tolerance:  $\pm 0.2$ , Unit: mm

- (1) Quantity: 2,000pcs./Reel
- (2) Cumulative Tolerance: Cumulative Tolerance/10pitches to be  $\pm 0.2$ mm
- (3) Adhesion Strength of Cover Tape: Adhesion strength to be 0.1-0.7N when the over tape is turned off from the carrier tape at  $10^\circ$  angle to be the carrier tape.
- (4) Package: P/N, Manufacturing data Code No. and quantity to be indicated on a damp proof Package.

SSC-LCW100Z1

Revision 1.3

www.ZLED.com

### 8. Reel Packing Structure

Reel

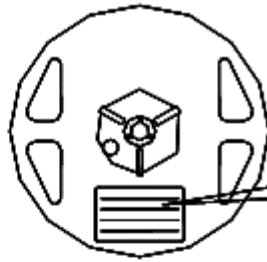

Aluminum Vinyl Bag

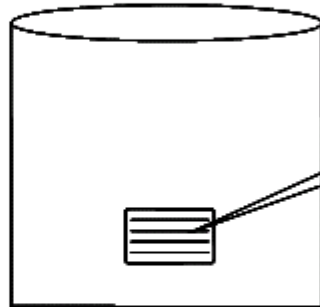

Outer Box

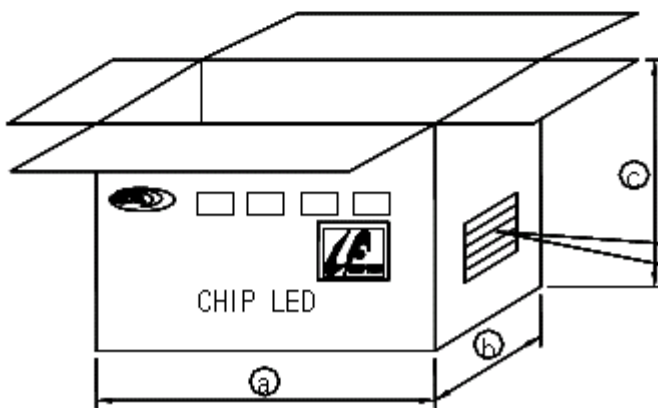

\*Material : Paper (SW3B(B))

TYPE	SIZE(mm)		
	a	b	c
7inch	245	220	142



SSC-LCW100Z1

Revision 1.3

www.ZLED.com

## 9. Soldering profile

### Reflow Soldering Conditions/ Profile

#### (1) Lead Solder

- Preliminary heating to be at 150°C max. for 2 minutes max.
- Soldering heat to be at 230 ± 5°C max. for 5 seconds max.

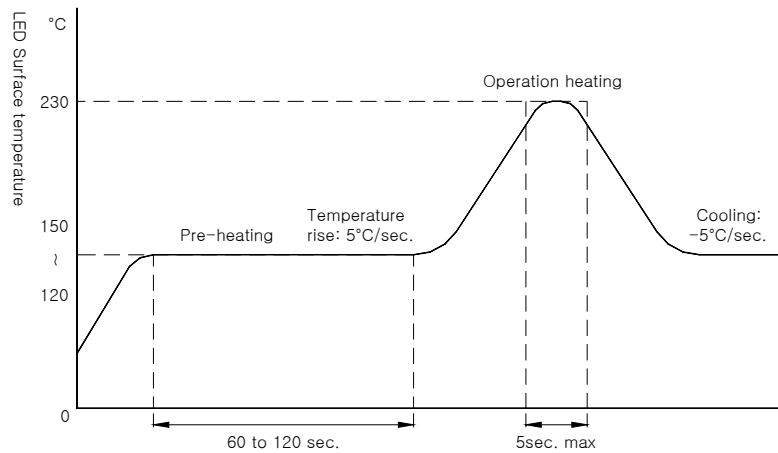

#### (2) Lead-Free Solder

- Preliminary heating to be at 150°C max. for 2 minutes max.
- Soldering heat to be at 255°C (+5/-0)°C max. for 10 seconds max.

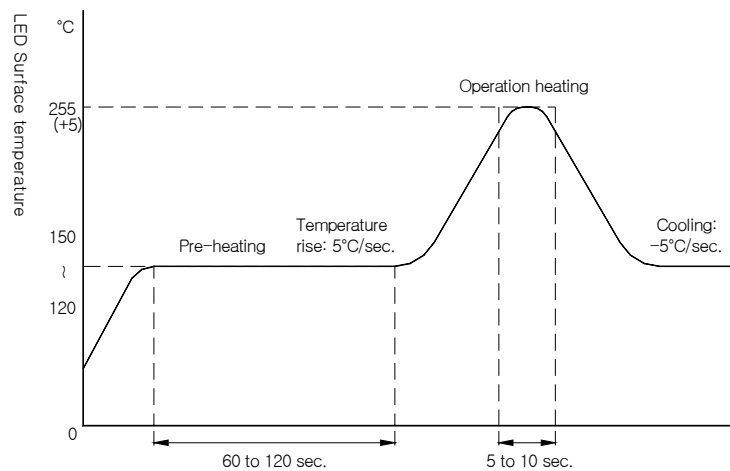

#### (3) Hand Soldering Condition

- Not more than 3 seconds @MAX280°C, under Soldering iron.

[Note] In case the soldered products are reused in soldering process, we don't guarantee the products.

SSC-LCW100Z1

Revision 1.3

www.ZLED.com

## 10. Precaution for Use

### 1. Storage

To avoid absorption of moisture, it is recommended to store parts in a dry box (or desiccator) with a desiccant. Otherwise, storage in the following environment is recommended.

※ Temperature : 5°C~30°C Humidity : 60%HR max.

2. Parts stored more than one week after opening or if desiccant indicator shower color changes, it is highly recommended that LED's should be baked for 10 ~ 12 hours at 60°C±5°C
3. LEDs must be stored at clean atmosphere. If the LEDs are stored for 3 months or more after shipment from SSC, storage in a sealed container with a nitrogen is recommended.
4. If the LED is considered to be wet, it is highly recommended that the LED should be dried for 100Hr at 80±5°C or 12Hr at 100±5°C.
5. Any mechanical force or excess vibration should be avoided during temperature cooling process to normal temperature after reflow.
6. Rapid cooling should be avoided
7. LED should not be placed on a flexible area of the PCB
8. This device should not be used in any type of fluid such as water, oil, organic solvent and etc. When washing is required, IPA should be used.
9. When the LED is operating in DC mode, the driving current should be determined after considering the thermal properties of the application and maximum ambient temperature requirements.
10. Damage prevention from ESD or Surge.
  - ☞ It is highly recommended to use the wrist-band or anti electrostatic gloves when handling the LED's
  - ☞ All devices, equipments and machines must be properly grounded



11. Order code

LCW100Z1 has an order code, use it as follows to purchase.

Order code	LF	CC	VF	Rank
1A	A B C D	A B	A B C D	AAA ~ AAD ABA ~ ABD BAA ~ BBG BBA ~ BBG CAA ~ CAD CBA ~ CBD DAA ~ DAD DBA ~ DBG
1B	A B C D	B C	A B C D	ABA ~ ABD ACA ~ ACD BBA ~ BBG BCA ~ BCD CBA ~ CBD CCA ~ CCD DBA ~ DBG DCA ~ DCD
1C	A B C D	D E	A B C D	ADA ~ ADD AEA ~ AED BDA ~ BDD BEA ~ BED CDA ~ CDD CEA ~ CED DDA ~ DDD DEA ~ DED
1D	A B C D	F G	A B C D	AFA ~ AFD AGA ~ AGD BFA ~ BFD BGA ~ BGD CFA ~ CFD CGA ~ CGD DFA ~ DFD DGA ~ DGD
1E	A B C D	G H	A B C D	AGA ~ AGD AHA ~ AHD BGA ~ BGD BHA ~ BHD CGA ~ CGD CHA ~ CHD DGA ~ DGD DHA ~ DHD

SSC-LCW100Z1

Revision 1.3

www.ZLED.com