

ANY-RATE 1–200 MHz QUAD FREQUENCY 8-OUTPUT CLOCK GENERATOR

Features

- Generates any frequency from 1 to 200 MHz on each of the 4 output banks
- Guaranteed 0 ppm frequency synthesis error for any combination of frequencies
- 25 or 27 MHz xtal or 5–200 MHz input clk
- Eight CMOS clock outputs
- Five programmable control pins (output enable, frequency select, reset)
- Separate OE pins to disable individual banks or all outputs
- Loss of signal output
- Low jitter: 50 ps pk-pk (typ), 100 ps pk-pk period jitter (max)
- Excellent PSRR performance eliminates need for external power supply filtering
- Low power: 45 mA
- Core VDD: 1.8, 2.5, or 3.3 V
- Separate VDDO for each bank of outputs: 1.8, 2.5, or 3.3 V
- Small size: 4x4 mm 24-QFN
- Industrial temperature range: –40 to +85 °C
- Custom versions available using ClockBuilder™ web utility
- Samples available in 2 weeks

Applications

- Printers
- Audio/video
- Residential gateways
- DSLAM
- Femtocells
- Storage area networks
- Switches/routers
- Servers

Description

The Si5355 is a highly flexible clock generator capable of synthesizing four completely non-integer related frequencies up to 200 MHz. The device has four banks of outputs with each bank supporting two CMOS outputs at the same frequency. Using Silicon Laboratories' patented MultiSynth fractional divider technology, all outputs are guaranteed to have 0 ppm frequency synthesis error regardless of configuration, enabling the replacement of multiple clock ICs and crystal oscillators with a single device. Through a flexible web configuration utility called ClockBuilder™ (www.silabs.com/ClockBuilder), factory-customized pin-controlled Si5355 devices are available in two weeks without minimum order quantity restrictions. The Si5355 supports up to three independent, pin-selectable device configurations, enabling one device to replace three separate clock ICs.

Functional Block Diagram

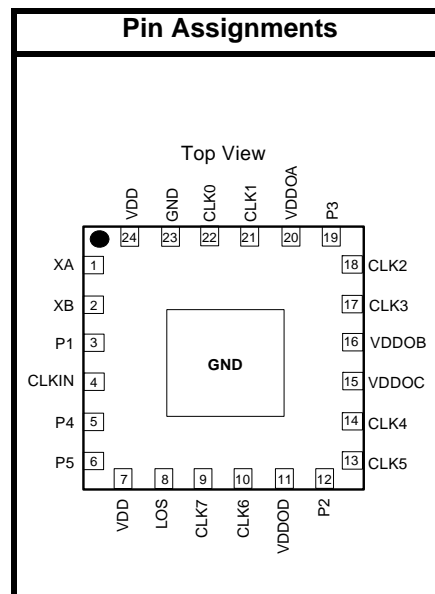
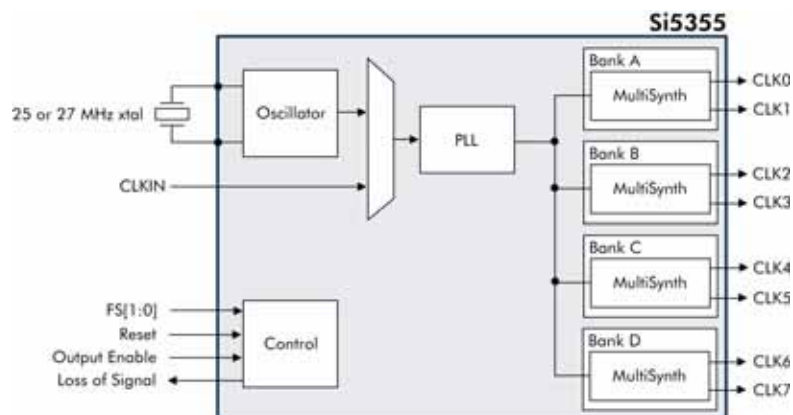

TABLE OF CONTENTS

<u>Section</u>	<u>Page</u>
1. Electrical Specifications	4
2. Typical Application Circuit	8
3. Functional Description	9
3.1. Input Configuration	9
3.2. Breakthrough MultiSynth Technology	9
3.3. Input and Output Frequency Configuration	10
3.4. Multi-Function Control Inputs	11
3.5. Output Enable	11
3.6. Frequency Select/Device Reset	11
3.7. Loss-of-Signal Alarm	12
3.8. CMOS Output Drivers	12
3.9. Jitter Performance	12
3.10. Power Supply Considerations	12
3.11. ClockBuilder Web-Customization Utility	13
4. Pin Descriptions—Si5355	14
5. Package Outline: 24-Lead QFN	17
6. Recommended PCB Layout	18
7. Ordering Guide	19
Document Change List	20
Contact Information	22

1. Electrical Specifications

Table 1. Recommended Operating Conditions

($V_{DD} = 1.8\text{ V} -5\%$ to $+10\%$, 2.5 or $3.3\text{ V} \pm 10\%$, $T_A = -40$ to $85\text{ }^\circ\text{C}$)

Parameter	Symbol	Test Condition	Min	Typ	Max	Units
Ambient Temperature	T_A		-40	—	85	$^\circ\text{C}$
Core Supply Voltage	V_{DD}		2.97	3.3	3.63	V
			2.25	2.5	2.75	
			1.71	1.8	1.98	
Output Buffer Supply Voltage	V_{DDO}		1.71	—	3.63	V

Note: All minimum and maximum specifications are guaranteed and apply across the recommended operating conditions. Typical values apply at nominal supply voltages and an operating temperature of $25\text{ }^\circ\text{C}$ unless otherwise noted.

Table 2. Absolute Maximum Ratings¹

Parameter	Symbol	Rating	Units
Supply Voltage Range	V_{DD}	-0.5 to +3.8	V
Input Voltage Range (all pins except pins 1,2,5,6)	V_I	-0.5 to 3.8	V
Input Voltage Range (pins 1,2,5,6)	V_{I2}	-0.5 to 1.2	V
Output Voltage Range	V_O	-0.5 to $V_{DD} + 0.3$	V
Storage Temperature Range	T_S	-55 to +150	$^\circ\text{C}$
ESD Tolerance	HBM	2.5	kV
	CDM	550	V
	MM	175	V
Latch-up Tolerance	LU	JESD78 Compliant	
Soldering Temperature (Pb-free profile) ²	T_{PEAK}	260	$^\circ\text{C}$

Notes:

- Permanent device damage may occur if the Absolute Maximum Ratings are exceeded. Functional operation should be restricted to the conditions as specified in the operational sections of this data sheet. Exposure to maximum rating conditions for extended periods may affect device reliability.
- The device is compliant with JEDEC J-STD-020C.

Table 3. DC Characteristics(V_{DD} = 1.8 V -5% to +10%, 2.5 or 3.3 V ±10%, T_A = -40 to 85 °C)

Parameter	Symbol	Test Condition	Min	Typ	Max	Units
Current Consumption	I _{DD}	100 MHz on all outputs, 25 MHz refclk	—	45	60	mA
High Level Input Voltage	V _{IH}	CLKIN (CMOS), OE, FS pins (P1,P2,P3)	0.8 x V _{DD}	—	—	V
		OE, pins (P4,P5)	TBD	—	—	V
Low Level Input Voltage	V _{IL}	CLKIN (CMOS), OE, FS pins (P1,P2,P3)	—	—	0.2 x V _{DD}	V
		OE, pins (P4,P5)	—	—	TBD	V
Clock Output High Level Output Voltage	V _{OH}	Pins: CLK0-7 I _{OH} = -4 mA	V _{DDO} - 0.3	—	—	V
Clock Output Low Level Output Voltage	V _{OL}	Pins: CLK0-7 I _{OH} = +4 mA	—	—	0.3	V
LOS Low Level Output Voltage	V _{OLLOS}	Pin: LOS I _{OH} = +3 mA	0	—	0.4	V
OE, FS Input Resistance	R _{IN}		20	—	—	kΩ

Table 4. AC Characteristics(V_{DD} = 1.8 V -5% to +10%, 2.5 or 3.3 V ±10%, T_A = -40 to 85 °C)

Parameter	Symbol	Test Condition	Min	Typ	Max	Units
Input Clock						
Clock Input Frequency	F _{IN}		5	—	200	MHz
Clock Input Rise/Fall Time	T _R /T _F	20 to 80% V _{DD}	—	—	4	ns
Clock Input Duty Cycle	DC	< 2 ns tr/ff	40	—	60	%
Clock Input Capacitance	C _{IN}		—	2	—	pF
Output Clocks						
Clock Output Frequency	F _O		1	—	200	MHz
Clock Output Frequency Synthesis Resolution	F _{RES}	See "3.3. Input and Output Frequency Configuration" on page 10	—	—	0	ppm
Output Load Capacitance	C _L		—	15	—	pF
Clock Output Rise/Fall Time	T _R /T _F	20 to 80% V _{DD} , C _L = 15 pF	—	—	1.7	ns
Clock Output Rise/Fall Time	T _R /T _F	20 to 80% V _{DD} , C _L = 2 pF	—	0.45	0.85	ns
Clock Output Duty Cycle	DC	Measured at V _{DD} /2	45	50	55	%
Powerup Time	T _{PU}	POR to output clock valid	—	—	2	ms
Output Enable Time	T _{OE}		—	—	10	µs
Output Transition Time	T _{TRANS}	After falling edge of reset	—	—	2	ms
Reset Minimum Pulse Width	T _{RESET}		—	—	200	ns
Output-Output Skew	T _{SKEW}	Outputs at same frequency, f _{OUT} > 5 MHz	-150	—	+150	ps
Loss of Signal (LOS) Detect Time	t _{LOS}		—	2.6	5	µs
Loss of Signal (LOS) Release Time	t _{LOSRLS}		0.01	0.2	1	µs
Period Jitter	J _{PPKPK}	10000 cycles	—	50	100	ps pk-pk
PLL Loop Bandwidth	F _{BW}		—	1.6	—	MHz

Table 5. Crystal Specifications

Parameter	Symbol	Test Condition	Min	Typ	Max	Units
Crystal Frequency	F _{XTAL}	Option 1	—	25	—	MHz
		Option 2	—	27	—	MHz
Load Capacitance (on-chip differential)	C _L		11	12	13	pF
Crystal Output Capacitance	C _O		—	—	4	pF
Equivalent Series Resistance	ESR	25 MHz	—	—	100	Ω
		27 MHz	—	—	75	Ω
Max Drive Level	d _L		100	—	—	μW

Table 6. Thermal Characteristics

Parameter	Symbol	Test Condition	Value	Units
Thermal Resistance Junction to Ambient	Theta JA	Still Air	37	°C/W

2. Typical Application Circuit

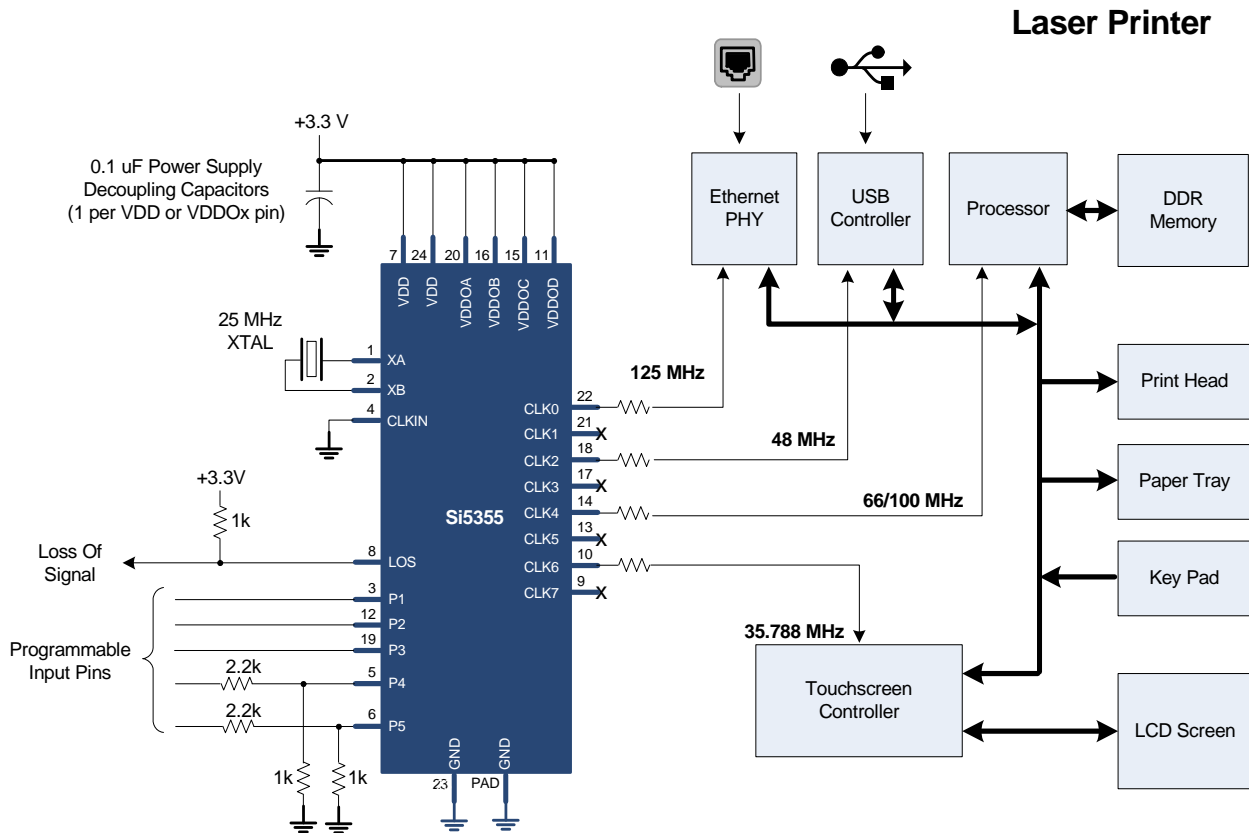
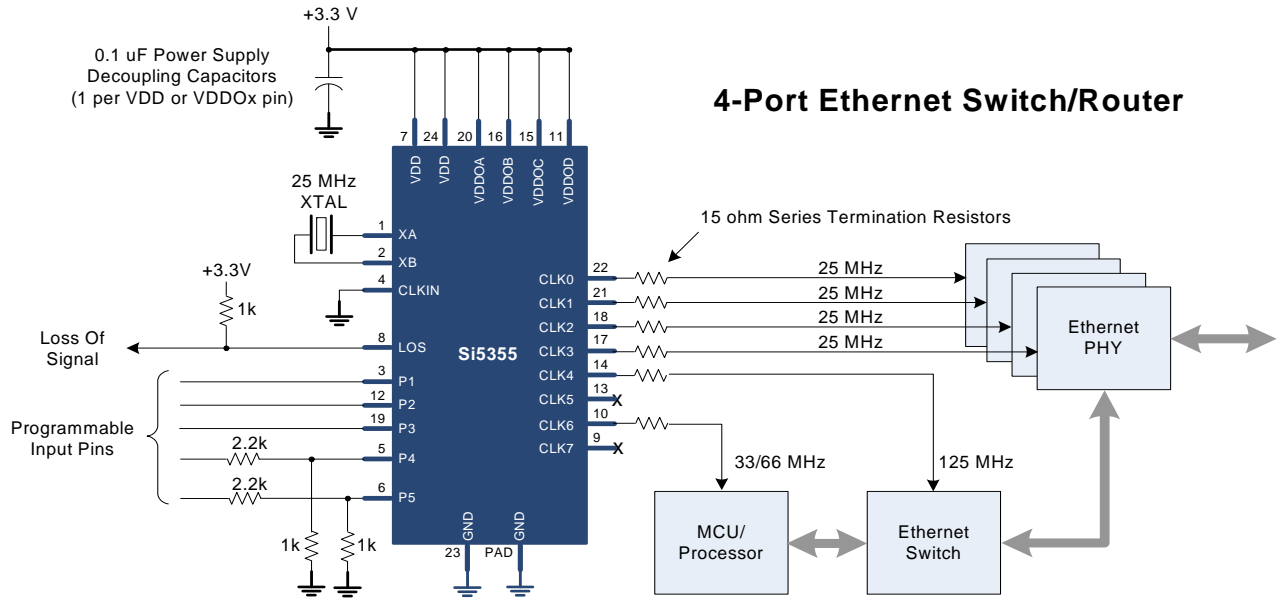

3. Functional Description

3.1. Input Configuration

The Si5355 input can be driven from either an external crystal or a reference clock. Reference selection is made when the device configuration is specified using the ClockBuilder™ web-based utility available at www.silabs.com/ClockBuilder. If the crystal input option is used, the Si5355 operates as a free-running clock generator. In this mode of operation the device requires a low cost 25 or 27 MHz fundamental mode crystal connected across XA and XB as shown in Figure 1. Given the Si5355's frequency flexibility, the same 25 or 27 MHz crystal can be reused to generate any combination of output frequencies. Custom frequency crystals are not required. The Si5355 integrates the crystal load capacitors on-chip to reduce external component count. The crystal should be placed very close to the device to minimize stray capacitance. To ensure stable oscillation, the recommended crystal specifications provided in Table 5 on page 7 must be followed. See AN360 for additional details regarding crystal recommendations.

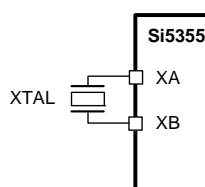

Figure 1. Connecting an XTAL to the Si5355

For synchronous timing applications, the Si5355 can lock to a 5 to 200 MHz CMOS reference clock.

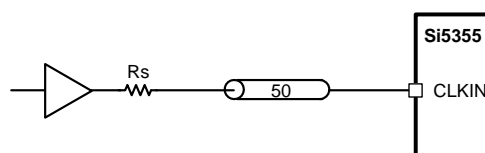

Figure 2. Interfacing CMOS Reference Clocks to the Si5355

3.2. Breakthrough MultiSynth Technology

Next-generation timing architectures require a wide range of frequencies which are often non-integer related. Traditional clock architectures address this by using a combination of 4-PLL ICs and discrete XOs, often at the expense of BOM complexity and power. The Si5355 uses patented MultiSynth technology to dramatically simplify timing architectures by integrating the frequency synthesis capability of 4 phase-locked loops (PLLs) in a single device, greatly minimizing size and power requirements versus traditional solutions. Based on a fractional-N PLL, the heart of the architecture is a low phase noise, high-frequency VCO. The VCO supplies a high frequency output clock to the MultiSynth block on each of the four independent output paths. Each MultiSynth operates as a high-speed fractional divider with Silicon Laboratories' proprietary phase error correction to divide down the VCO clock to the required output frequency with very low jitter.

The first stage of the MultiSynth architecture is a fractional-N divider which switches seamlessly between the two closest integer divider values to produce the exact output clock frequency with 0 ppm error. To eliminate phase error generated by this process, MultiSynth calculates the relative phase difference between the clock produced by the fractional-N divider and the desired output clock and dynamically adjusts the phase to match the ideal clock waveform. This novel approach makes it possible to generate any output clock frequency without sacrificing jitter performance. Based on this architecture, the output of each MultiSynth can produce any frequency from 1 to 200 MHz.

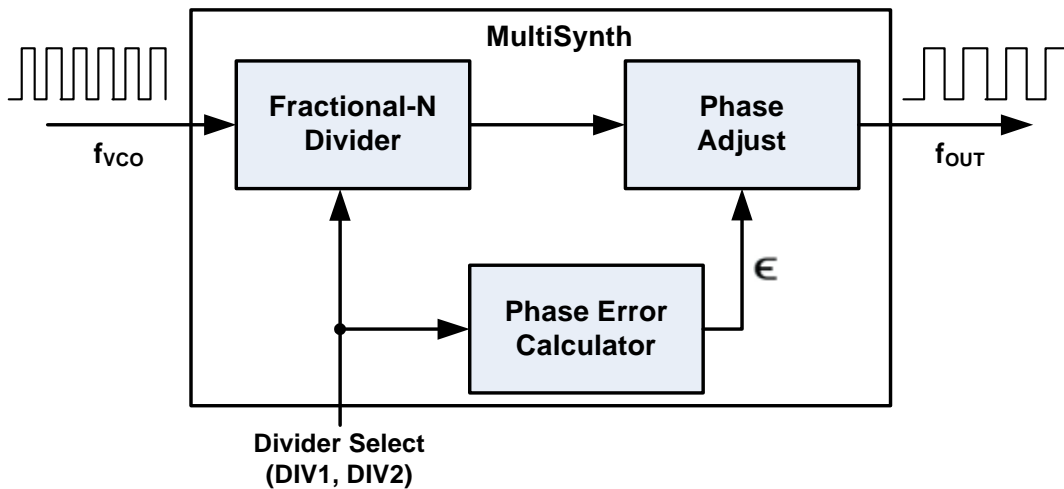

Figure 3. Silicon Labs' MultiSynth Technology

3.3. Input and Output Frequency Configuration

The Si5355 utilizes a single PLL-based architecture, four independent MultiSynth fractional output dividers, and a MultiSynth fractional feedback divider such that a single device provides the clock generation capability of 4 independent PLLs. Unlike competitive multi-PLL solutions, the Si5355 can generate four unique non-integer related output frequencies with 0 ppm frequency error for any combination of output frequencies. In addition, any combination of output frequencies can be generated from a single reference frequency without having to change the crystal or reference clock frequency between frequency configurations.

The Si5355 frequency configuration is set when the device configuration is specified using the ClockBuilder web-based utility available at www.silabs.com/ClockBuilder. Any combination of output frequencies ranging from 5 to 200 MHz can be configured on each of the device outputs. Up to three unique device configurations can be specified in a single device, enabling the Si5355 to replace 3 different clock generators.

The following equation governs how the output frequency is calculated.

$$f_{OUT} = \frac{f_{IN} \times N}{P \times M_i}$$

where f_{IN} is the reference frequency, N is the MultiSynth feedback divider value, P is the reference divider value, M_i is the MultiSynth output divider value and f_{OUT} is the resulting output frequency. The MultiSynth output and feedback dividers are fractional dividers expressed in terms of an integer and a fraction. The integer portion has 10-bit resolution and the fractional portion has 30-bit resolution in both the numerator and denominator, meaning that any output frequency can be defined exactly from the input frequency with exact (0 ppm) frequency synthesis error.

3.4. Multi-Function Control Inputs

The Si5355 supports 5 user-defined input pins (pins 3, 5, 6, 12, 19) that are customizable to support the functions listed below. The pinout of each device is customized using the ClockBuilder utility. This enables the device to be custom tailored to a specific application. Each of the different functions is described in further detail below.

Pin Function	Description	Assignable Pin Name
\overline{OE}	Output Enable. All outputs enabled when low.	P1, P2, P3, P4, or P5
\overline{OEA}	Output Enable Bank A. CLK0/1 enabled when low.	P1, P2, P3, P4, or P5
\overline{OEB}	Output Enable Bank B. CLK2/3 enabled when low.	P1, P2, P3, P4, or P5
\overline{OEC}	Output Enable Bank C. CLK4/5 enabled when low.	P1, P2, P3, P4, or P5
\overline{OED}	Output Enable Bank D. CLK6/7 enabled when low.	P1, P2, P3, P4, or P5
FS0	Frequency Select. Selects active device frequency plan from factory-configured profiles.	P1, P2, or P3
FS1	Frequency Select. Selects active device frequency plan from factory-configured profiles.	P1, P2, or P3
RESET	Reset. Device reset required to change FS[1:0] pin setting.	P1, P2, P3, P4, or P5

3.5. Output Enable

Each of the device's four banks of CMOS clock outputs can be individually disabled using \overline{OEA} , \overline{OEB} , \overline{OEC} and \overline{OED} , respectively. Alternatively, all clock outputs can be disabled using the master output enable \overline{OE} . When a Si5355 clock output bank is disabled, both outputs are driven to an active low state. When one or more banks of clock outputs are enabled or disabled, clock start and stop transitions are handled glitchlessly.

3.6. Frequency Select/Device Reset

The device frequency plan is customized using the ClockBuilder web utility. The Si5355 optionally supports up to three unique, pin-selectable configurations per device, enabling one device to replace up to three separate clock ICs. To select a particular frequency plan, set the FS pins as outlined below:

For custom Si5355 devices configured to support 2 frequency plans, the FS pin should be set as follows:

FS	Profile
0	1
1	2

For custom Si5355 devices configured to support 3 frequency plans, the FS[1:0] pins should be set as follows:

FS[1:0]	Profile
00	Reserved
01	1
10	2
11	3

Si5355

If a change is made to the FS[1:0] pin settings, the device reset pin (Reset) must be held high for the minimum pulse width specified in Table 4 on page 6 to change the device configuration. The output clocks will be momentarily squelched until the device begins operation with the new frequency plan.

The corresponding input/output frequency configuration (profiles) for a custom Si5355 device can be looked up using the ClockBuilder web-based utility.

3.7. Loss-of-Signal Alarm

The Si5355 supports a loss of signal (LOS) output indicator for monitoring the condition of the crystal/clock reference input. When no input clock signal edges are detected over the observation period specified in Table 4 on page 6, the clock outputs will be indeterminate until the input clock reappears and is revalidated.

LOS Setting	Description
0	No loss of signal
1	Loss of signal present

3.8. CMOS Output Drivers

The Si5355 has 4 banks of outputs with each bank comprised of 2 clocks for a total of 8 CMOS outputs per device. Each of the output banks can operate from a different VDDO supply (1.8 V, 2.5 V, 3.3 V), simplifying usage in mixed supply applications. All clock outputs between 5 and 200 MHz are in-phase to within ± 150 ps. When an output bank is disabled using any of the OE functions, the clock outputs are stopped low.

3.9. Jitter Performance

The Si5355 provides consistently low jitter for any combination of output frequencies. The device leverages a low phase noise single PLL architecture and Silicon Laboratories' patented MultiSynth fractional output divider technology to deliver period jitter less than 100 ps pk-pk (max) for any frequency plan. This level of jitter performance is guaranteed across process, temperature and voltage. The Si5355 provides superior performance to traditional multi-PLL solutions which may suffer from degraded jitter performance depending on frequency plan and the number of active PLLs.

3.10. Power Supply Considerations

The Si5355 has 2 core supply voltage pins (V_{DD}) and 4 clock output bank supply voltage pins (V_{DDOA} – V_{DDOD}), enabling the device to be used in mixed supply applications. The Si5355 does not require ferrite beads for power supply filtering. The device has extensive on-chip power supply regulation to minimize the impact of power supply noise on output jitter. Figure 4 shows that the additive jitter created when a significant amount of noise is applied to the device power supply is very small.

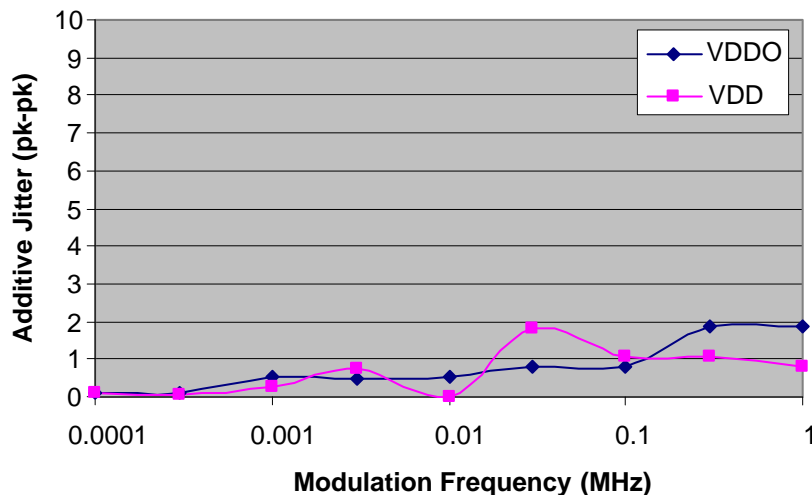

Figure 4. Peak-to-Peak Additive Jitter from 100 mV Sine Wave on Supply

3.11. ClockBuilder Web-Customization Utility

ClockBuilder is a web-based utility available at www.silabs.com/ClockBuilder that allows hardware designers to tailor the Si5355's flexible clock architecture to meet any application-specific requirements and order custom clock samples. Through a simple point-and-click interface, users can specify any combination of input frequency and output frequencies and generate a custom part number for each application-specific configuration. In addition to creating part numbers, this utility can be used to order samples and place production orders. There are no minimum order quantity restrictions.

ClockBuilder enables mass customization of clock generators. This allows a broader range of applications to take advantage of using application-specific pin controlled clocks, simplifying design while eliminating the firmware development required by traditional I²C-programmable clock generators.

Based on Silicon Labs' patented MultiSynth technology, the device PLL output frequency is constant and all clock output frequencies are synthesized by the four MultiSynth fractional dividers. All PLL parameters, including divider settings, VCO frequency, loop bandwidth, charge pump current, and phase margin are internally set by the device during the configuration process. This ensures optimized jitter performance and loop stability while simplifying design.

4. Pin Descriptions—Si5355

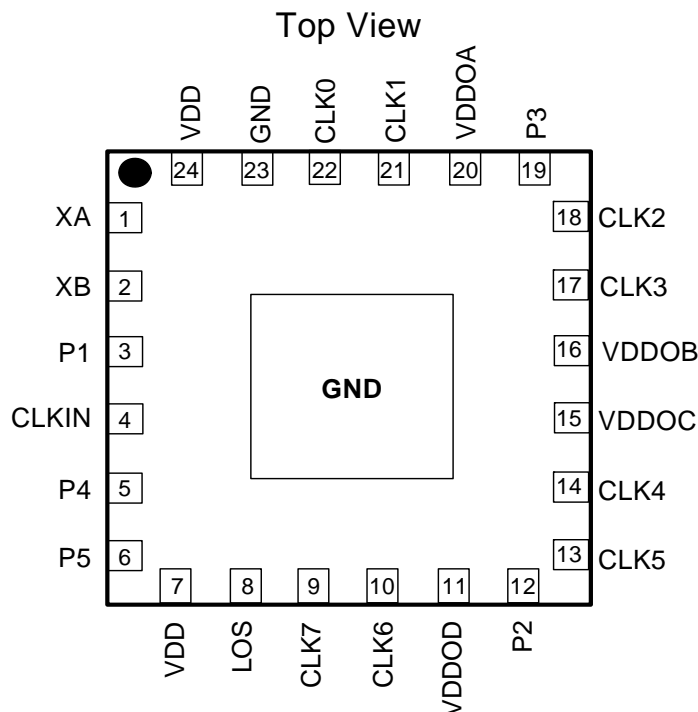

Note: Center pad must be tied to GND for normal operation.

Table 7. Si5355 Pin Descriptions

Pin #	Pin Name	I/O	Description
1	XA	I	External Crystal. If a 25 or 27 MHz crystal is used as the device frequency reference, connect it across XA and XB. If no input clock is used, this pin should be tied to GND.
2	XB	I	External Crystal. If a 25 or 27 MHz crystal is used as the device frequency reference, connect it across XA and XB. If no input clock is used, this pin should be tied to GND.
3	P1	I	Multi-Function Input. This pin functions as a multi-function input pin. The pin function ($\overline{\text{OE}}$, $\overline{\text{OEA}}$, $\overline{\text{OEB}}$, $\overline{\text{OEC}}$, $\overline{\text{OED}}$, Frequency Select, or Reset) is user-selectable at time of configuration using the ClockBuilder configuration utility.
4	CLKIN	I	Single-Ended Input Clock. If a single-ended clock is used as the device frequency reference, connect it to this pin. This pin functions as a high-impedance input for CMOS clock signals. The input should be dc coupled. If a crystal is used as the device frequency reference, this pin should be tied to GND.

Table 7. Si5355 Pin Descriptions (Continued)

5	P4	I	<p>Multi-Function Input. This pin functions as a multi-function input pin. The pin function (\overline{OE}, \overline{OEA}, \overline{OEB}, \overline{OEC}, \overline{OED}, or Reset) is user-selectable at time of configuration using the ClockBuilder configuration utility. Must be connected to open drain driver; see Typical Application Diagram for details.</p>
6	P5	I	<p>Multi-Function Input. This pin functions as a multi-function input pin. The pin function (\overline{OE}, \overline{OEA}, \overline{OEB}, \overline{OEC}, \overline{OED}, or Reset) is user-selectable at time of configuration using the ClockBuilder configuration utility. Must be connected to open drain driver; see Typical Application Diagram for details.</p>
7	VDD	VDD	<p>Core Supply Voltage. The device operates from a 1.8, 2.5, or 3.3 V supply. A 0.1 μF bypass capacitor should be located very close to this pin.</p>
8	LOS	O	<p>Loss of Signal. This pin functions as an input clock loss of signal status pin. 0 = no loss of signal 1 = loss of signal present This pin is open drain and requires an external ≥ 1 kΩ pullup resistor.</p>
9	CLK7	O	<p>Output Clock 7. CMOS output clock. If unused, this pin must be left floating.</p>
10	CLK6	O	<p>Output Clock 6. CMOS output clock. If unused, this pin must be left floating.</p>
11	VDDOD	VDD	<p>Clock Output Bank D Supply Voltage. Power supply for clock outputs 6 and 7. May be operated from a 1.8, 2.5, or 3.3 V supply. A 0.1 μF bypass capacitor should be located very close to this pin. If CLK6/7 are not used, this pin must be tied to pin 7 and/or pin 24.</p>
12	P2	I	<p>Multi-Function Input. This pin functions as a multi-function input pin. The pin function (\overline{OE}, \overline{OEA}, \overline{OEB}, \overline{OEC}, \overline{OED}, Frequency Select, or Reset) is user-selectable at time of configuration using the ClockBuilder configuration utility</p>
13	CLK5	O	<p>Output Clock 5. CMOS output clock. If unused, this pin must be left floating.</p>
14	CLK4	O	<p>Output Clock 4. CMOS output clock. If unused, this pin must be left floating.</p>
15	VDDOC	VDD	<p>Clock Output Bank C Supply Voltage. Power supply for clock outputs 4 and 5. May be operated from a 1.8, 2.5 or 3.3 V supply. A 0.1 μF bypass capacitor should be located very close to this pin. If CLK4/5 are not used, this pin must be tied to pin 7 and/or pin 24.</p>
16	VDDOB	VDD	<p>Clock Output Bank B Supply Voltage. Power supply for clock outputs 2 and 3. May be operated from a 1.8, 2.5, or 3.3 V supply. A 0.1 μF bypass capacitor should be located very close to this pin. If CLK2/3 are not used, this pin must be tied to pin 7 and/or pin 24.</p>
17	CLK3	O	<p>Output Clock 3. CMOS output clock. If unused, this pin must be left floating.</p>

Table 7. Si5355 Pin Descriptions (Continued)

18	CLK2	O	Output Clock 2. CMOS output clock. If unused, this pin must be left floating.
19	P3	I	Multi-Function Input. This pin functions as a multi-function input pin. The pin function (\overline{OE} , \overline{OEA} , \overline{OEB} , \overline{OEC} , \overline{OED} , Frequency Select, or Reset) is user-selectable at time of configuration using the ClockBuilder configuration utility
20	VDDOA	VDD	Clock Output Bank A Supply Voltage. Power supply for clock outputs 0 and 1. May be operated from a 1.8, 2.5, or 3.3 V supply. A 0.1 μ F bypass capacitor should be located very close to this pin. If CLK0/1 are not used, this pin must be tied to pin 7 and/or pin 24.
21	CLK1	O	Output Clock 1. CMOS output clock. If unused, this pin must be left floating.
22	CLK0	O	Output Clock 0. CMOS output clock. If unused, this pin must be left floating.
23	GND	GND	Ground. Must be connected to system ground. Minimize the ground path impedance for optimal performance of the device.
24	VDD	VDD	Core Supply Voltage. The device operates from a 1.8, 2.5, or 3.3 V supply. A 0.1 μ F bypass capacitor should be located very close to this pin.
GND PAD	GND	GND	Ground Pad. This is the large pad in the center of the package. Nine or more vias should be used to connect this pad to a ground plane. Device specifications cannot be guaranteed unless the ground pad is properly connected to a ground plane on the PCB.

5. Package Outline: 24-Lead QFN

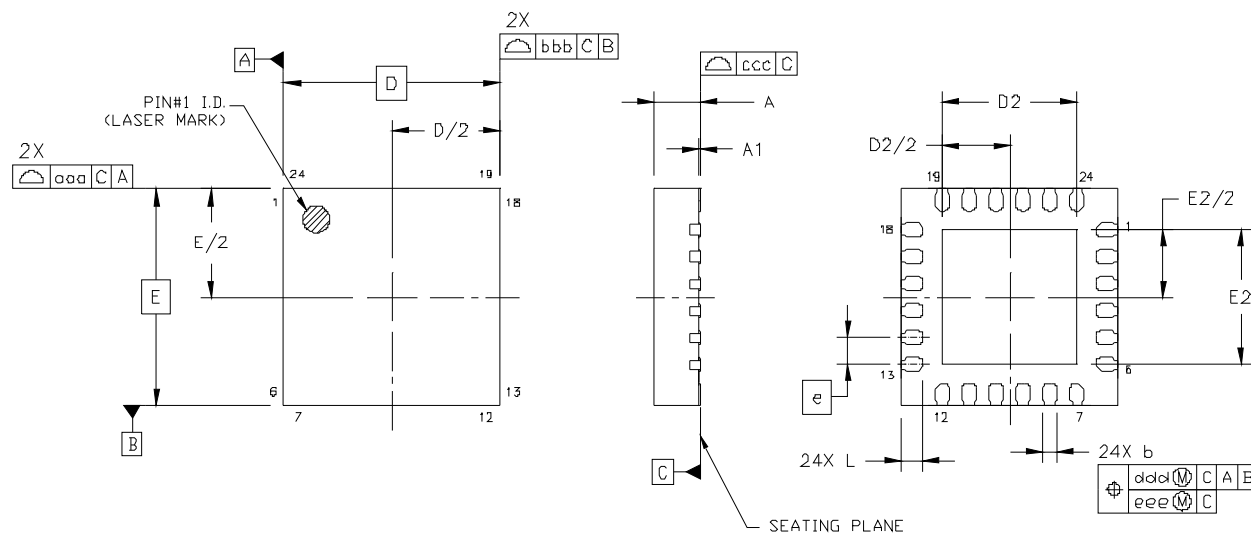

Figure 5. 24-Lead Quad Flat No-Lead (QFN)

Table 8. Package Dimensions

Dimension	Min	Nom	Max
A	0.80	0.85	0.90
A1	0.00	0.02	0.05
b	0.18	0.25	0.30
D	4.00 BSC.		
D2	2.35	2.50	2.65
e	0.50 BSC.		
E	4.00 BSC.		
E2	2.35	2.50	2.65
L	0.30	0.40	0.50
aaa	0.10		
bbb	0.10		
ccc	0.08		
ddd	0.10		
eee	0.05		

Notes:

- All dimensions shown are in millimeters (mm) unless otherwise noted.
- Dimensioning and Tolerancing per ANSI Y14.5M-1994.
- This drawing conforms to the JEDEC Outline MO-220, variation VGGD-8.
- Recommended card reflow profile is per the JEDEC/IPC J-STD-020C specification for Small Body Components.

6. Recommended PCB Layout

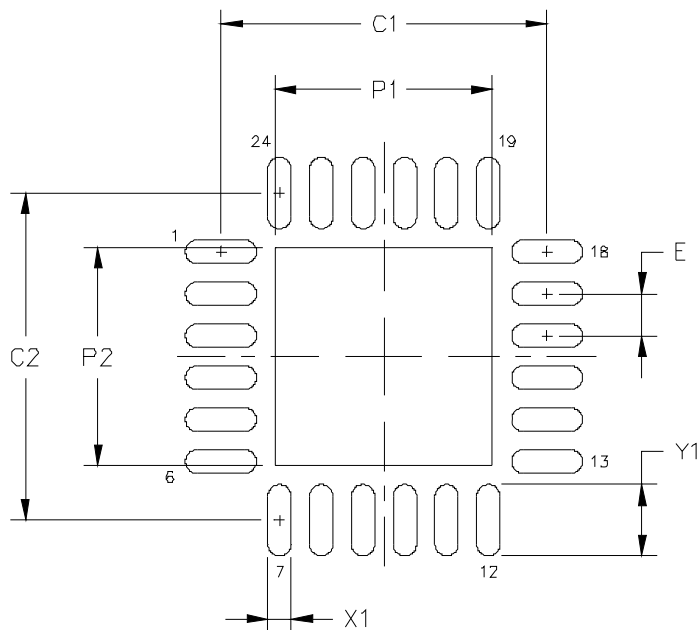

Table 9. PCB Land Pattern

Dimension	Min	Nom	Max
P1	2.50	2.55	2.60
P2	2.50	2.55	2.60
X1	0.20	0.25	0.30
Y1	0.75	0.80	0.85
C1		3.90	
C2		3.90	
E		0.50	

Notes:

General

1. All dimensions shown are in millimeters (mm) unless otherwise noted.
2. Dimensioning and Tolerancing per ANSI Y14.5M-1994 specification.
3. This Land Pattern Design is based on the IPC-7351 guidelines.

Solder Mask Design

4. All metal pads are to be non-solder mask defined (NSMD). Clearance between the solder mask and the metal pad is to be 60 μm minimum, all the way around the pad.

Stencil Design

5. A stainless steel, laser-cut and electro-polished stencil with trapezoidal walls should be used to assure good solder paste release.
6. The stencil thickness should be 0.125 mm (5 mils).
7. The ratio of stencil aperture to land pad size should be 1:1 for all perimeter pins.
8. A 2x2 array of 1.0 mm square openings on 1.25 mm pitch should be used for the center ground pad.

Card Assembly

9. A No-Clean, Type-3 solder paste is recommended.
10. The recommended card reflow profile is per the JEDEC/IPC J-STD-020C specification for Small Body Components.

7. Ordering Guide

Use the ClockBuilder web-based utility available at www.silabs.com/ClockBuilder to specify a unique Si5355 device configuration. ClockBuilder assigns a unique 5-digit code for each unique device configuration and creates an orderable part number. The utility may also be used to order samples, place production orders and look up existing part numbers. In addition, ClockBuilder generates a data sheet addendum for each unique part number that summarizes the device input frequency, output frequencies and other configuration parameters for that specific part number.

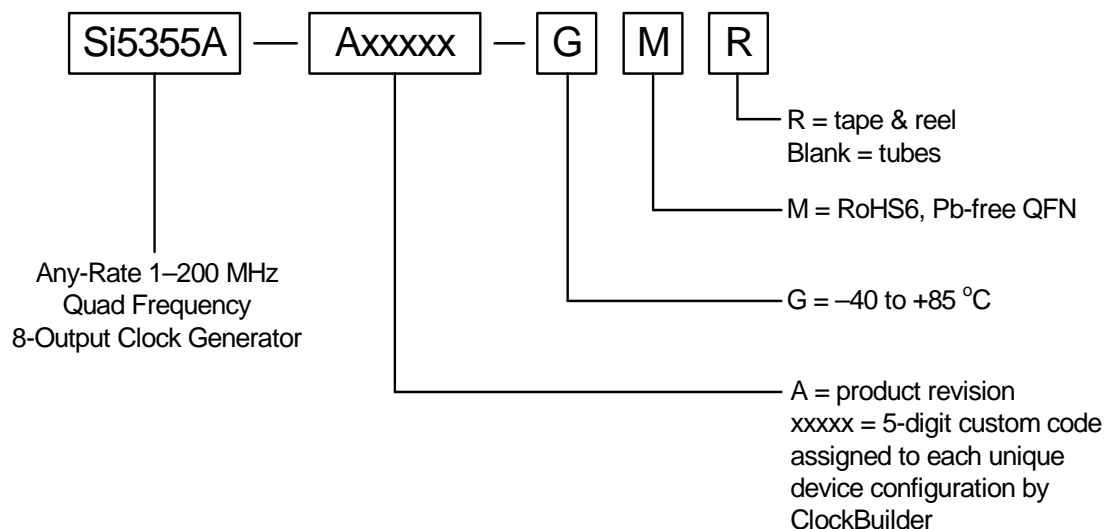

DOCUMENT CHANGE LIST

Revision 0.1 to Revision 0.2

- Documentation updated to reflect CLKIN is on pin 4, not pin 3.

NOTES:

CONTACT INFORMATION

Silicon Laboratories Inc.

400 West Cesar Chavez
Austin, TX 78701
Tel: 1+(512) 416-8500
Fax: 1+(512) 416-9669
Toll Free: 1+(877) 444-3032

Please visit the Silicon Labs Technical Support web page:
<https://www.silabs.com/support/pages/contacttechnicalsupport.aspx>
and register to submit a technical support request.

The information in this document is believed to be accurate in all respects at the time of publication but is subject to change without notice. Silicon Laboratories assumes no responsibility for errors and omissions, and disclaims responsibility for any consequences resulting from the use of information included herein. Additionally, Silicon Laboratories assumes no responsibility for the functioning of undescribed features or parameters. Silicon Laboratories reserves the right to make changes without further notice. Silicon Laboratories makes no warranty, representation or guarantee regarding the suitability of its products for any particular purpose, nor does Silicon Laboratories assume any liability arising out of the application or use of any product or circuit, and specifically disclaims any and all liability, including without limitation consequential or incidental damages. Silicon Laboratories products are not designed, intended, or authorized for use in applications intended to support or sustain life, or for any other application in which the failure of the Silicon Laboratories product could create a situation where personal injury or death may occur. Should Buyer purchase or use Silicon Laboratories products for any such unintended or unauthorized application, Buyer shall indemnify and hold Silicon Laboratories harmless against all claims and damages.

Silicon Laboratories, Silicon Labs, and ClockBuilder are trademarks of Silicon Laboratories Inc.
Other products or brandnames mentioned herein are trademarks or registered trademarks of their respective holders.