

## High Side Current Monitor

### 8V to 450V, Configurable Output

#### Features

- ▶ Supply voltage 8V to 450V
- ▶ Configurable as a current or voltage output device
- ▶ Maximum sense amplifier offset of 5mV
- ▶ Max  $V_{SENSE}$  of 500mV
- ▶ Fast rise and fall times, from 700ns to 1.4 $\mu$ s
- ▶ Maximum quiescent current of 50 $\mu$ A

#### Applications

- ▶ SMPS current monitor
- ▶ Battery current monitor
- ▶ Motor control

#### General Description

The HV7802 high side current monitor IC contains a transconductance amplifier which translates a high side current measurement voltage into an output current with resistor programmable transconductance gain. An optional second resistor transforms this output current into an output voltage with an overall voltage gain set by the ratio of the two resistors.

The measurement voltage typically originates at a current sense resistor, which is located in a "high side" circuit, for example a circuit not directly associated with ground.

This monitor IC features a very wide input voltage range, configurable gain, small size, low component count, low power consumption, ease of use, and low cost. Offline applications, battery, and portable applications can be served equally well due to the wide input voltage range and the low quiescent current.

#### Typical Application Circuit

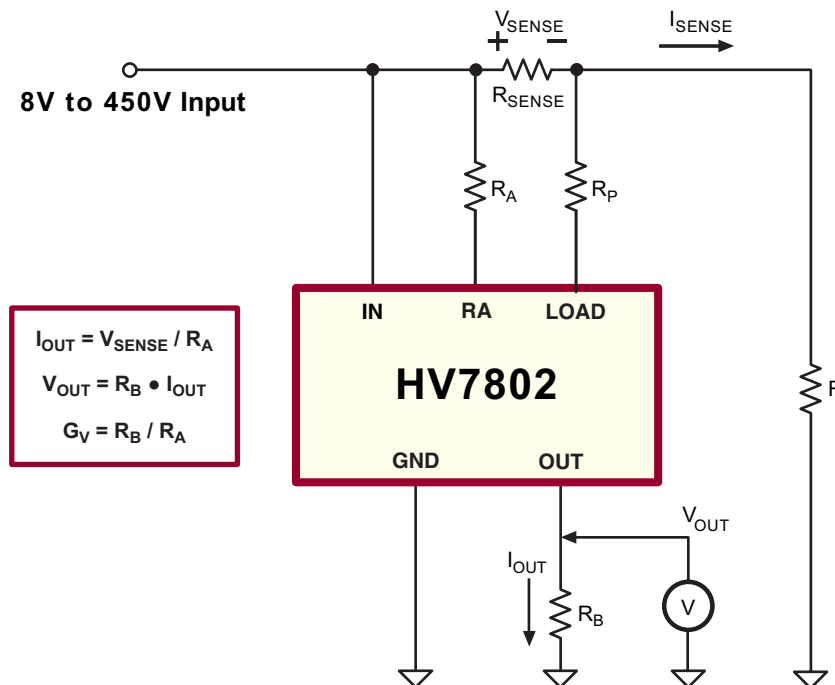

## Ordering Information

Device	Package Option
	8-Lead MSOP
HV7802	HV7802MG-G

-G indicates package is RoHS compliant ("Green")



## Absolute Maximum Ratings

Parameter	Value
$V_{IN}, V_{LOAD}$	-0.5V to +450V
$V_{OUT}$	-0.5V to +10V
$V_{SENSE}$	-0.5V to +5.0V
$I_{LOAD}$	$\pm 10\text{mA}$
Operating ambient temperature	0°C to +70°C
Operating junction temperature	-40°C to +125°C
Storage temperature	-65°C to +150°C

Absolute maximum ratings are those values beyond which damage to the device may occur. Functional operation under these conditions is not implied. Continuous operation of the device at the absolute rating level may affect device reliability. All voltages are referenced to device ground.

## Thermal Resistance

Package	$\theta_{ja}$
8-Lead MSOP	220 °C/W

Note: Thermal testboard per JEDEC JESD51-7

## Pin Configuration

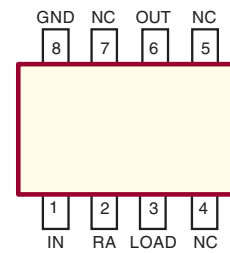

**8-Lead MSOP**  
(top view)

## Electrical Characteristics ( $T_A = 25^\circ\text{C}$ unless otherwise specified, $V_{SENSE} = V_{IN} - V_{LOAD}$ , $V_{IN} = 8.0\text{V}$ to $450\text{V}$ )

Symbol	Parameter	Min	Typ	Max	Units	Conditions
--------	-----------	-----	-----	-----	-------	------------

### Supply

$V_{IN}$	Supply voltage*	8.0	-	450	V	---
$I_Q$	Quiescent supply current	-	-	50	$\mu\text{A}$	$V_{IN} = 8\text{V}$ to $450\text{V}$ , $V_{SENSE} = 0\text{mV}$

### Input and Output

$I_{OUT}$	Output current	-	-	200	$\mu\text{A}$	---
$V_{OUT}$	Output voltage, $R_A = R_B = 5.000\text{k}\Omega$	0	-	10	mV	$V_{SENSE} = 0\text{mV}$
		89	-	111		$V_{SENSE} = 100\text{mV}$
		188	-	212		$V_{SENSE} = 200\text{mV}$
		485	-	515		$V_{SENSE} = 500\text{mV}$

### Dynamic Characteristics

$t_{RISE}$	Output rise time, 10% to 90%	-	0.7	0.8	$\mu\text{s}$	$V_{SENSE}$ step 5.0mV to 500mV
		-	-	1.4		$V_{SENSE}$ step 0mV to 500mV
$t_{FALL}$	Output fall time, 90% to 10%	-	0.7	0.8	$\mu\text{s}$	$V_{SENSE}$ step 500mV to 0mV

\*Values apply over the full temperature range.

## Block Diagram

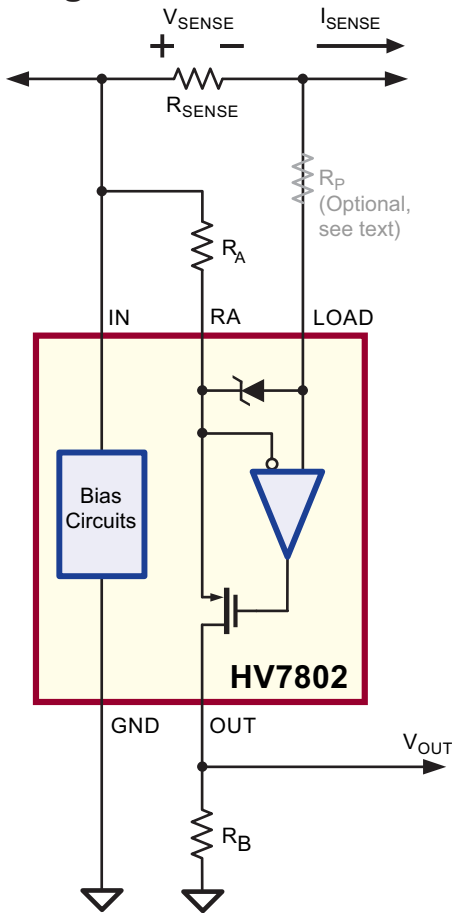

- ▶ The current to be measured does not flow in a circuit associated with ground.
- ▶ The measurement at ground level can lead to ambiguity due to changes in the grounding arrangement during field use.
- ▶ The introduction of a sense resistor in the system ground is undesirable due to issues with safety, EMI, or signal degradation caused by common impedance coupling.

## Principle of Operation

The operational amplifier forces the voltage across  $R_A$  to track  $V_{SENSE}$ , therefore,  $V_{RA} = V_{SENSE}$ . Transconductance gain is equal to  $(1/R_A)$ .

$I_{RA}$  flows from the OUT pin to low side circuitry. Current to voltage conversion can be accomplished by a resistor,  $R_B$ , as shown in the block diagram, with a transimpedance gain equal to  $R_B$ .

Typically we would like to exploit the full current capability of the transimpedance amplifier. A  $R_A$  of  $5k\Omega$  will provide this current, assuming a full scale sense voltage of  $500mV$  and a full scale sense current of  $100\mu A$ .

In a voltage output application, the output resistor  $R_B$  is determined by the desired overall voltage gain of  $(R_B / R_A)$ . For example, a  $R_B$  of  $10k\Omega$  results in a voltage gain of two.

## Application Information

### General

The HV7802 high side current monitor IC features accurate current sensing, small size, low component count, low power consumption, exceptional input voltage range, ease of use and low cost.

Typical use is measurement of line and load current for purpose of overcurrent protection, metering and current regulation.

High side current sensing, as opposed to ground referenced or low side current sensing, is desirable or required when:

### OUT Pin Loading Effects

Note that the output is not buffered having an output impedance equal to  $R_B$ . Loading of the output causes voltage gain to drop and rise and fall times to increase.

For example, assume a gain of one, using  $R_A = R_B = 5k\Omega$ . In this case the load resistance should exceed  $5M\Omega$  in order to limit the gain drop to 1 part in 1000.

Assuming an output resistance of  $5k\Omega$ , a capacitive load of  $20pF$  results in a load pole with a time constant of  $100ns$ , not enough to materially affect the output rise and fall time (about  $700ns$ ).

### Sense Resistor Considerations

Limit the sense resistor voltage to 500mV during normal operating conditions. Limit the power dissipation in the sense resistor to suit the application; a high sense voltage benefits accuracy, but may result in high power dissipation as well.

Consider the use of Kelvin connections for applications where considerable voltage drops may occur in the PCB traces. A layout pattern, which minimizes voltage drops across the sense lines is shown below.

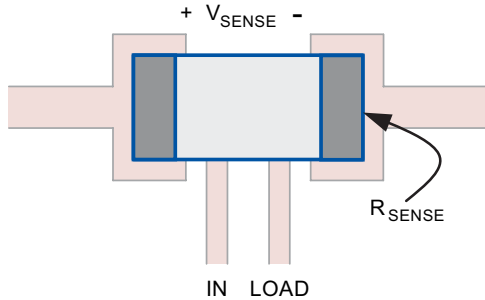

Choose a low inductance type sense resistor if preservation of bandwidth is important. Kelvin connections help by minimizing the inductive voltage drops as well. The inductive voltage drop may be substantial when operating at high frequency. A trace or component inductance of just 10nH contributes an impedance of 6.2mΩ at 100kHz, which constitutes a 6% error when using a 100mΩ sense resistor.

### Transient Protection

Add a protection resistor ( $R_p$ ) in series with the LOAD pin if  $V_{SENSE}$  can exceed 5V in positive sense or 600mV in negative sense, whether in steady state or in transient conditions.

A large  $V_{SENSE}$  may occur during system startup or shutdown when charging and discharging large capacitors.  $V_{SENSE}$  may be large due to fault conditions, such as short circuit or a broken or missing sense resistor.

An internal 5V Zener diode with a current rating of 10mA protects the sense amplifier inputs. The block diagram shows the orientation of this diode. The Zener diode provides clamping at 5V for a positive  $V_{SENSE}$  and at 600mV for a negative  $V_{SENSE}$ .

Limit the Zener current to 10mA under worst case conditions. A 100kΩ resistor limits the maximum Zener diode current to 4.5mA when  $V_{SENSE}$  is 450V, whether positive or negative. Note that the protection resistor may affect bandwidth. The resistor forms a RC network with the trace and pin capacitance at the LOAD pin. For example, capacitance of 5pF results in a time constant of 500ns.

The protection resistor may cause an offset voltage due to bias current at the LOAD input. A 100kΩ protection resistor could cause an offset of 100μV, or 0.2% of full scale, under worst case bias current. Note that bias current is nominally zero since LOAD is a high impedance CMOS input, resulting in zero bias current induced offset voltage.

### Pin Description

Pin #	Pin Name	Description
1	IN	Sense amplifier input and supply.
2	RA	Provides gain setting of the transconductance amplifier. Connect gain setting resistor ( $R_A$ ) between Pin 1 and Pin 2.
3	LOAD	Sense amplifier input. High impedance input with Zener diode protection. Add an external protection resistor in series with LOAD if $V_{SENSE}$ exceeds the range of -600mV to +5V.
4	NC	No Connect. This pin must be left floating for proper operation
5	NC	No Connect. This pin must be left floating for proper operation.
6	OUT	Output of the transconductance amplifier. Output current to output voltage conversion can be accomplished through addition of an external resistor ( $R_B$ ) at this pin. Overall voltage gain is determined by the ratio of $R_B$ to $R_A$ .
7	NC	No connect. This pin must be left floating for proper operation.
8	GND	Supply return.

8-Lead MSOP (MG) Package Outline

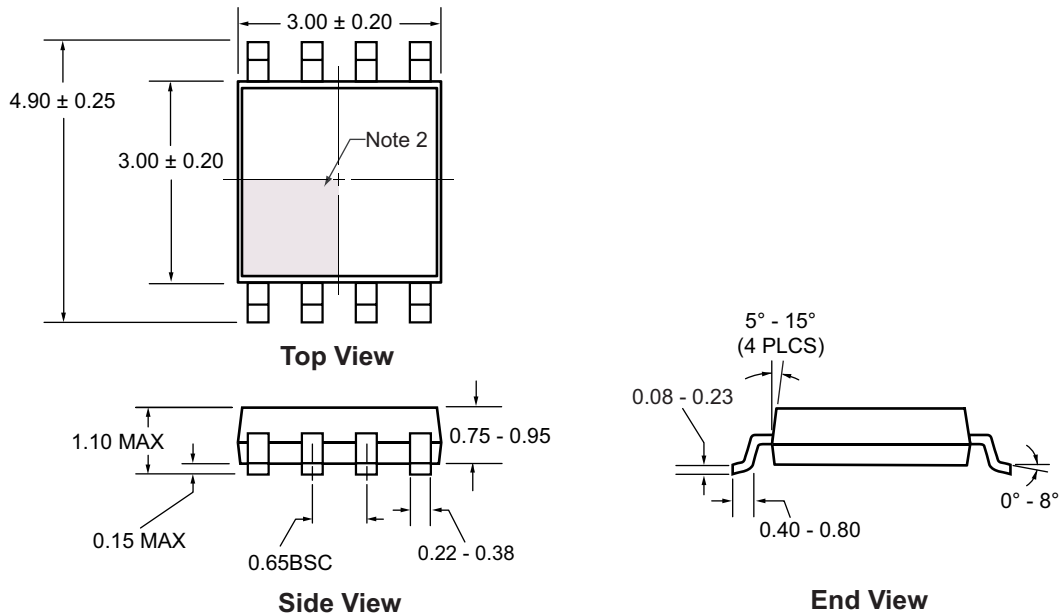

Notes:

1. All dimensions in millimeters; angles in degrees
2. Pin 1 identifier must be located within the indicated area

(The package drawing(s) in this data sheet may not reflect the most current specifications. For the latest package outline information go to <http://www.supertex.com/packaging.html>.)

**Supertex inc.** does not recommend the use of its products in life support applications, and will not knowingly sell its products for use in such applications, unless it receives an adequate "product liability indemnification insurance agreement". **Supertex** does not assume responsibility for use of devices described and limits its liability to the replacement of the devices determined defective due to workmanship. No responsibility is assumed for possible omissions or inaccuracies. Circuitry and specifications are subject to change without notice. For the latest product specifications, refer to the **Supertex** website: <http://www.supertex.com>.