

Hysteretic, Buck, High Brightness LED Driver with High-Side Current Sensing

Features

- ▶ Hysteretic control with high-side current sensing
- ▶ Integrated 40V 1.0Ω MOSFET
- ▶ >90% Efficiency
- ▶ Wide input voltage range: 4.5 to 40V
- ▶ ±5% LED current accuracy
- ▶ Up to 2.0MHz switching frequency
- ▶ Adjustable constant LED current
- ▶ Analog or PWM control signal for PWM dimming
- ▶ Over-temperature protection
- ▶ -40°C to +125°C operating temperature range

Applications

- ▶ Low voltage industrial and architectural lighting
- ▶ General purpose constant current source
- ▶ Signage and decorative LED lighting
- ▶ Indicator and emergency lighting

General Description

The HV9918 is a PWM controller IC designed to drive high brightness LEDs using a buck topology. It operates from an input voltage of 4.5 to 40VDC and employs hysteretic control with a high-side current sense resistor to set the constant output current up to 700mA. The device is well suited for applications requiring a wide input voltage range. The high-side current sensing and an integrated current-setting circuitry minimize the number of external components while delivering an accurate average output.

Dedicated pulse-width modulation (PWM) input enables pulsed LED dimming over a wide range of brightness levels. A hysteretic control method ensures excellent input supply rejection and fast response during load transients and PWM dimming.

The HV9918 offers an analog-controlled PWM dimming feature that reduces the output current by applying an external DC voltage below the internal 2.0V threshold voltage from ADIM to GND. ADIM can also accept input from a resistor divider including a negative temperature coefficient (NTC) thermistor connected between ADIM and GND, or a positive temperature coefficient (PTC) thermistor connected between ADIM and VDD thus providing a PWM thermal-foldback feature that reduces the LED current when the temperature of the LED string exceeds a specified temperature point. Additional features include thermal-shutdown protection.

The high switching frequency up to 2.0MHz permits the use of small inductors and capacitors, minimizing space and cost in the overall system.

The HV9918 comes in a small 8-Lead DFN package and is ideal for industrial and general lighting applications.

Typical Application Circuit

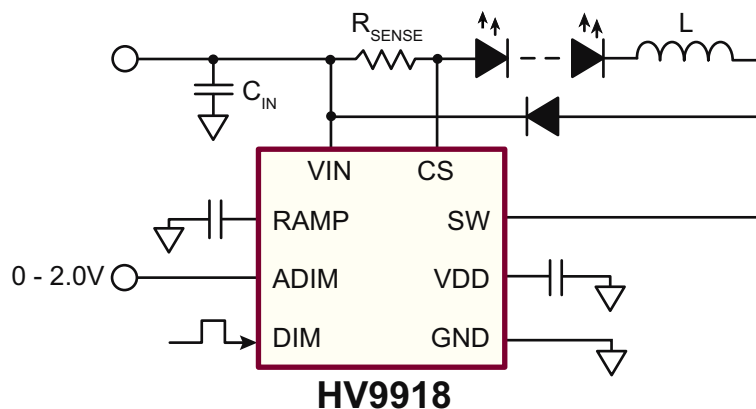

Ordering Information

Device	Package Options
	8-Lead DFN 3.00x3.00mm body, 0.80mm height (max), 0.65mm pitch
HV9918	HV9918K7-G

-G indicates package is RoHS compliant ('Green')



Pin Description

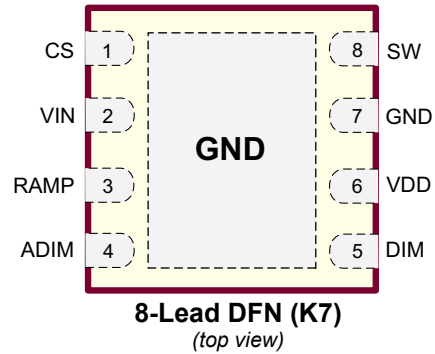

Product Marking

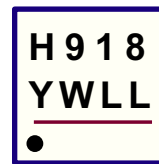

Y = Last Digit of Year Sealed
 W = Code for Week Sealed
 L = Lot Number
 — = "Green" Packaging

8-Lead DFN (K7)

Absolute Maximum Ratings

Parameter	Value
V _{IN} , CS, SW to GND	-0.3 to +45V
V _{DD} , RAMP, DIM, ADIM to GND	-0.3 to +6.0V
CS to VIN	-1.0 to +0.3V
Continuous power dissipation, (T _A = +25°C)	1.6W
Operating temperature range	-40°C to +125°C
Junction temperature	+150°C
Storage temperature range	-65°C to +150°C

Stresses beyond those listed under "Absolute Maximum Ratings" may cause permanent damage to the device. These are stress ratings only, and functional operation of the device at these or any other conditions beyond those indicated in the operational sections of the specifications is not implied. Exposure to absolute maximum rating conditions for extended periods may affect device reliability.

Thermal Resistance

Package	θ_{ja}
8-Lead DFN (K7)	60°C/W

Mounted on FR-4 board, 25mm x 25mm x 1.57mm

Electrical Characteristics

(V_{IN} = 12V, V_{DIM} = V_{DD}, V_{RAMP} = GND, C_{VDD} = 1.0μF, R_{CS} = 0.5Ω, T_A = T_J = -40°C to +125°C* unless otherwise noted)

Sym	Description	Min	Typ	Max	Units	Conditions
V _{IN}	Input DC supply voltage range	4.5	-	40	V	DC input voltage
V _{DD}	Internally regulated voltage	4.5	-	5.5	V	V _{IN} = 6.0 to 40V
I _{IN}	Supply current	-	-	1.5	mA	SW = GND
I _{IN, SDN}	Shutdown supply current	-	-	750	μA	DIM < 0.7V
I _{IN, LIM}	Current limit	-	30	-	mA	V _{IN} = 4.5V, V _{DD} = 0V
		-	8.0	-		V _{IN} = 4.5V, V _{DD} = 4.0V
f _{SW}	Switching frequency	-	-	2.0	MHz	---
UVLO	V _{DD} Undervoltage lockout threshold	-	-	4.5	V	V _{DD} rising
ΔUVLO	V _{DD} Undervoltage lockout hysteresis	-	500	-	mV	V _{DD} falling

* Guaranteed by design and characterization, 100% tested at T_A = 25°C. Typical characteristics are given at T_A = 25°C.

Electrical Characteristics

($V_{IN} = 12V$, $V_{DIM} = V_{DD}$, $V_{RAMP} = GND$, $C_{VDD} = 1.0\mu F$, $R_{CS} = 0.5\Omega$, $T_A = T_J = -40^\circ C$ to $+125^\circ C$ * unless otherwise noted)

Sym	Description	Min	Typ	Max	Units	Conditions
-----	-------------	-----	-----	-----	-------	------------

Sense Comparator

$V_{RS(HI)}$	Sense voltage threshold high	222	-	248	mV	$(V_{IN} - V_{CS})$ rising
$V_{RS(LO)}$	Sense voltage threshold low	165	-	182	mV	$(V_{IN} - V_{CS})$ falling
t_{DPDL}	Propagation delay to SW off	-	70	-	ns	Rising edge of $(V_{IN} - V_{CS}) = V_{RS(HI)} + 70mV$ to $V_{SW} = 0.5 \cdot V_{IN}$
t_{DPDH}	Propagation delay to SW on	-	70	-	ns	Falling edge of $(V_{IN} - V_{CS}) = V_{RS(LO)} - 70mV$ to $V_{SW} = 0.5 \cdot V_{IN}$
I_{CS}	Current-sense input current	-	-	1.0	μA	$(V_{IN} - V_{CS}) = 200mV$
$I_{CS(HYS)}$	Current-sense threshold hysteresis	-	56	70	mV	---

DIM Input

V_{IH}	Pin DIM input high voltage	2.2	-	-	V	---
V_{IL}	Pin DIM input low voltage	-	-	0.7	V	---
t_{ON}	Turn-on time	-	100	-	ns	DIM rising edge to $V_{SW} = 0.5 \cdot V_{IN}$
t_{OFF}	Turn-off time	-	100	-	ns	DIM falling edge to $V_{SW} = 0.5 \cdot V_{IN}$

Output Switch

I_{DC}	SW continuous current	-	-	0.7	A	---
R_{ON}	ON resistance	-	1.0	2.0	Ω	---
I_{LEAK}	SW leakage current	-	10	-	μA	---

Over-Temperature Protection

T_{OT}	Over temperature trip limit	128	140	-	$^\circ C$	---
ΔT_{HYST}	Temperature hysteresis	-	60	-	$^\circ C$	---

Analog Control of PWM Dimming

f_{RAMP}	Dimming frequency	170	-	255	Hz	$C_{RAMP} = 47nF$
		800	-	1200		$C_{RAMP} = 10nF$
V_{LOW}	RAMP threshold, Low	-	0.1	-	V	---
V_{HIGH}	RAMP threshold, High	1.84	-	1.96	V	---
V_{OS}	ADIM offset voltage	-20	-	+20	mV	---

* Guaranteed by design and characterization, 100% tested at $T_A = 25^\circ C$. Typical characteristics are given at $T_A = 25^\circ C$.

Block Diagram

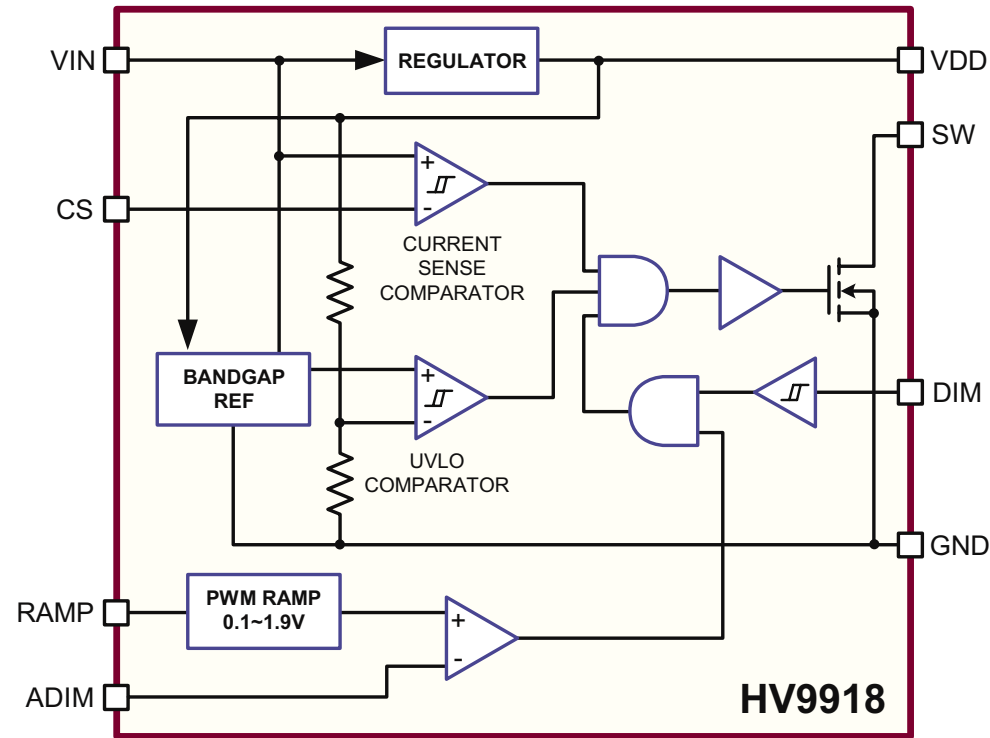

Application Information

General Description

The HV9918 is a step-down, constant current, high-brightness LED (HB LED) driver. The device operates from a 4.5 to 40V input voltage range, and includes an internal 40V 1.0Ω N-channel MOSFET. A high-side current sense resistor sets the output current and a dedicated PWM dimming input (DIM) allows for a wide range of dimming duty ratios. PWM dimming can also be achieved by applying a DC voltage between 0 and 2.0V to the analog dimming input (ADIM). In this case, the dimming frequency can be programmed using a single capacitor at the RAMP pin. The high-side current setting and sensing scheme minimizes the number of external components while delivering LED current with ±5% accuracy using a 1% sense resistor.

Undervoltage Lockout (UVLO)

The HV9918 includes a 3.7V under-voltage lockout (UVLO) with 500mV hysteresis. When V_{IN} falls below 3.7V, switching of SW is disabled. Switching of SW resumes once V_{IN} is 4.2V or higher.

5.0V Regulator

VDD is the output of a 5.0V regulator capable of sourcing 8mA. Bypass VDD to GND with a 1.0μF capacitor.

DIM Input

The HV9918 allows dimming with a PWM signal at the DIM input. A logic level below 0.8V at DIM halts SW switching, turning the LED current off. To turn the LED current back on, the logic level at DIM must be at least 2.0V.

ADIM and RAMP Inputs

The PWM dimming scheme can be also implemented by applying an analog control signal to ADIM pin. If an analog control signal of 0 ~ 2.0V is applied to ADIM, the device compares this analog input to a voltage ramp to pulse-width-modulate the LED current. Connecting an external capacitor to RAMP programs the PWM dimming ramp frequency.

$$f_{PWM} = \frac{10^{-5}}{C_{RAMP}}$$

DIM and ADIM inputs can be used simultaneously. In such case, $f_{PWM(MAX)}$ must be selected lower than the frequency of the dimming signal at DIM. The smaller dimming duty cycle of ADIM and DIM will determine the GATE signal.

One possible application of the ADIM feature of the HV9918 may include protection of the LED load from over-temperature by connecting an NTC thermistor at ADIM, as shown in Figure 1.

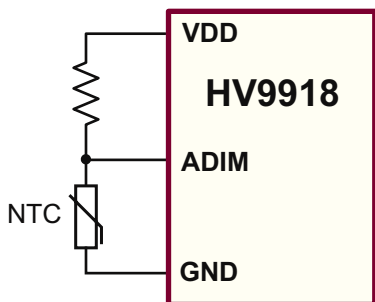

Figure 1

Setting LED Current with External Resistor R_{SENSE}

The output current in the LED is determined by the external current sense resistor (R_{SENSE}) connected between VIN and CS. Disregarding the effect of the propagation delays, the sense resistor can be calculated as:

$$R_{SENSE} \approx \frac{1}{2} \cdot \frac{(V_{RS(HI)} + V_{RS(LO)})}{I_{LED}} = \frac{200mV}{I_{LED}}$$

Selecting Buck Inductor L

The HV9918 regulates the LED output current using an input comparator with hysteresis (Figure 2). As the current through

the inductor ramps up and the voltage across the sense resistor reaches the upper threshold, the internal MOSFET at SW turns off. The MOSFET turns on again when the inductor current ramps down through the freewheeling diode until the voltage across the sense resistor equals the lower threshold. Use the following equation to determine the inductor value for a desired value of operating frequency f_s :

$$L = \frac{(V_{IN} - V_{OUT})V_{OUT}}{f_s V_{IN} \Delta I_o} - \frac{(V_{IN} - V_{OUT})t_{DPDL}}{\Delta I_o} - \frac{V_{OUT}t_{DPDH}}{\Delta I_o}$$

where:

$$\Delta I_o = \frac{V_{RS(HI)} - V_{RS(LO)}}{R_{SENSE}}$$

and t_{DPDL} , t_{DPDH} are the propagation delays. Note, that the current ripple ΔI in the inductor L is greater than ΔI_o . This ripple can be calculated from the following equation:

$$\Delta I = \Delta I_o + \frac{(V_{IN} - V_{OUT})t_{DPDL}}{L} + \frac{V_{OUT}t_{DPDH}}{L}$$

For the purpose of the proper inductor selection, note that the maximum switching frequency occurs at the highest V_{IN} and $V_{OUT} = V_{IN}/2$.

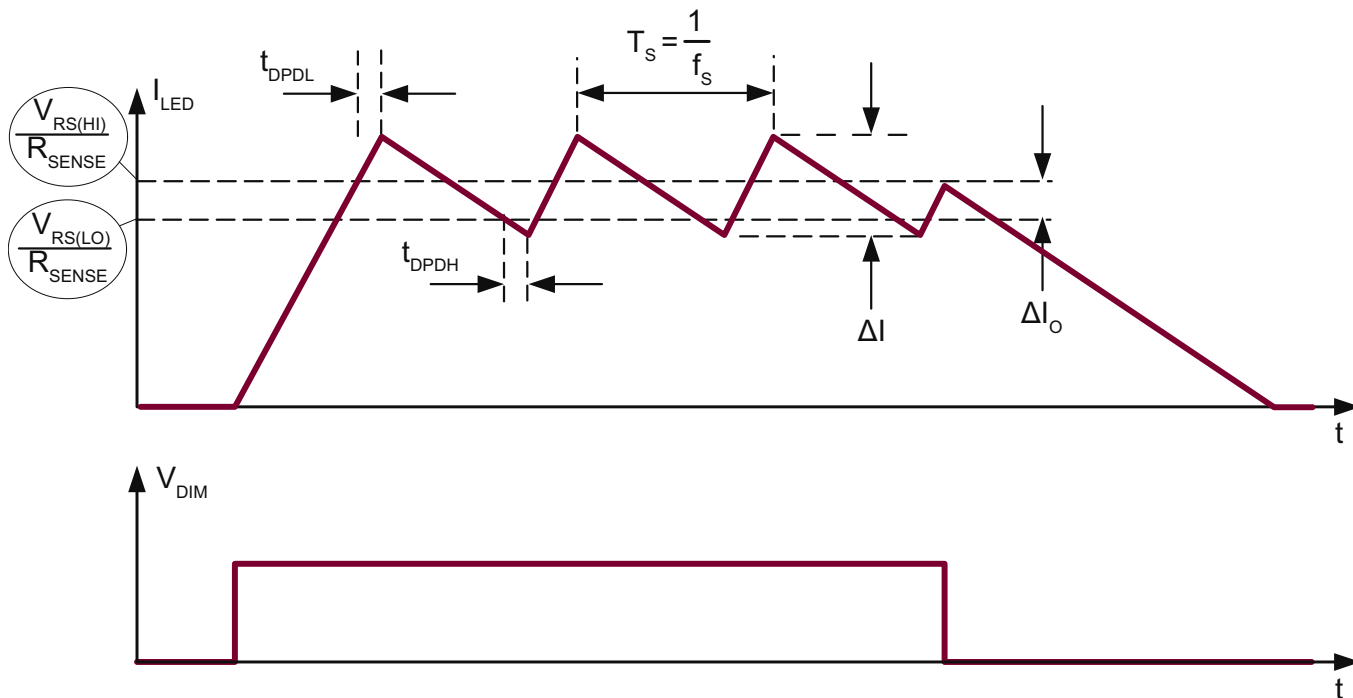

Figure 2

Thermal Shutdown

The HV9918 thermal-shutdown feature turns off the SW driver when the junction temperature exceeds +140°C. The SW driver turns back on when the junction temperature drops 60°C below the shutdown temperature threshold.

Freewheeling Diode Selection

The forward voltage of the freewheeling diode should be as low as possible for better efficiency. A Schottky diode is a good choice as long as the breakdown voltage is high enough to withstand the maximum operating voltage. The forward current rating of the diode must be at least equal to the maximum LED current.

LED Current Ripple

The LED current ripple is equal to the inductor current ripple. In cases when a lower LED current ripple is needed, a capacitor can be placed across the LED terminals.

PCB Layout Guidelines

Careful PCB layout is critical to achieve low switching losses and stable operation. Use a multilayer board whenever possible for better noise immunity. Minimize ground noise by connecting high-current ground returns, the input bypass capacitor ground lead, and the output filter ground lead to a single point (star ground configuration). The fast di/dt loop is formed by the input capacitor C_{IN} , the free-wheeling diode and the HV9918 switching MOSFET. To minimize noise interaction, this loop area should be as small as possible. Place R_{SENSE} as close as possible to the input filter and VIN. For better noise immunity, a Kelvin connection is strongly recommended between CS and R_{SENSE} . Connect the exposed tab of the IC to a large-area ground plane for improved power dissipation.

Pin Description

Pin #	Pin	Description
1	CS	Current sense input. Senses LED string current.
2	VIN	Input voltage 4.5 to 40V DC.
3	RAMP	Analog PWM dimming ramp output.
4	ADIM	Analog 0 ~ 2.0V signal input for analog control of PWM dimming.
5	DIM	PWM signal input.
6	VDD	Internally regulated supply voltage. Connect a capacitor from VDD to ground.
7	GND	Device ground.
8	SW	Open Drain Output of an internal 40V 1.0Ω MOSFET.
TAB	GND	Must be wired to pin 7 on PCB.

8-Lead DFN Package Outline (K7)

3.00x3.00mm body, 0.80mm height (max), 0.65mm pitch

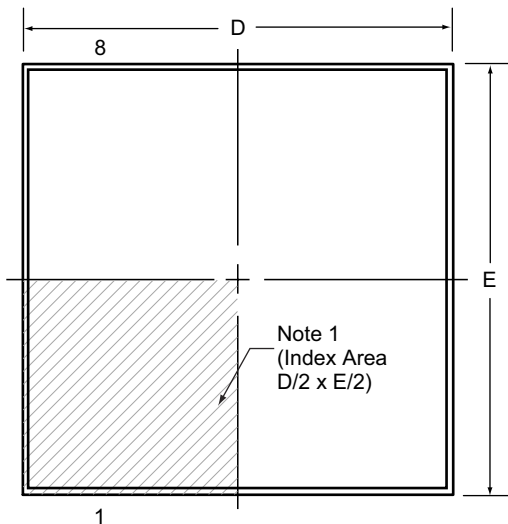

Top View

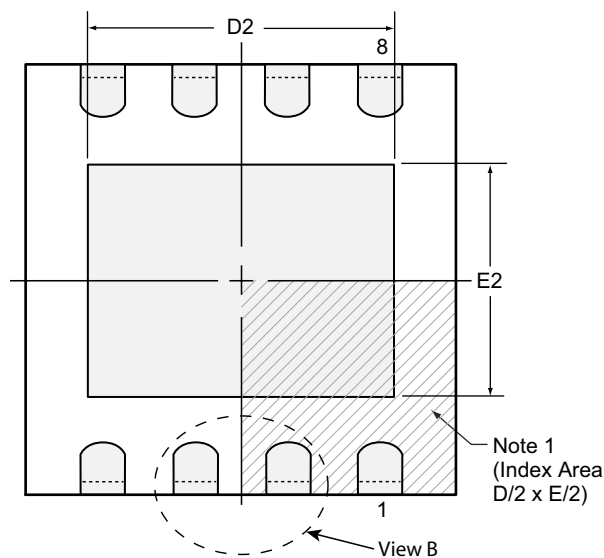

Bottom View

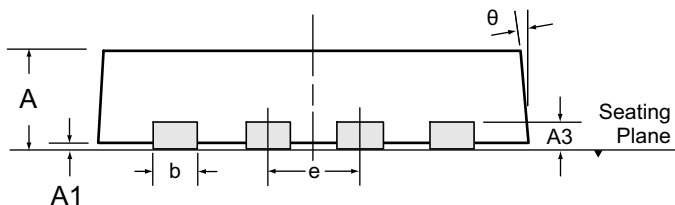

Side View

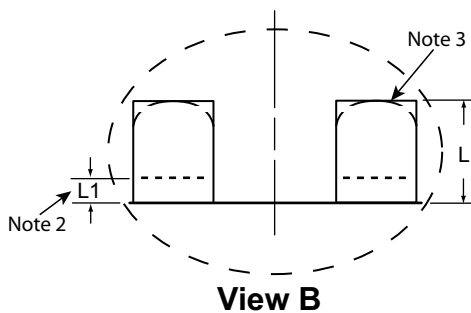

View B

Notes:

1. A Pin 1 identifier must be located in the index area indicated. The Pin 1 identifier can be: a molded mark/identifier; an embedded metal marker; or a printed indicator.
2. Depending on the method of manufacturing, a maximum of 0.15mm pullback (L1) may be present.
3. The inner tip of the lead may be either rounded or square.

Symbol	A	A1	A3	b	D	D2	E	E2	e	L	L1	θ	
Dimension (mm)	MIN	0.70	0.00	0.20 REF	0.25	2.85*	1.60	2.85*	1.35	0.65 BSC	0.30	0.00*	0°
	NOM	0.75	0.02		0.30	3.00	-	3.00	-		0.40	-	-
	MAX	0.80	0.05		0.35	3.15*	2.50	3.15*	1.75		0.50	0.15	14°

JEDEC Registration MO-229, Variation WEEC-2, Issue C, Aug. 2003.

* This dimension is not specified in the JEDEC drawing.

Drawings not to scale.

Supertex Doc. #: DSPD-8DFNK73X3P065, Version C041009.

(The package drawing(s) in this data sheet may not reflect the most current specifications. For the latest package outline information go to <http://www.supertex.com/packaging.html>.)

Supertex inc. does not recommend the use of its products in life support applications, and will not knowingly sell them for use in such applications unless it receives an adequate "product liability indemnification insurance agreement." Supertex inc. does not assume responsibility for use of devices described, and limits its liability to the replacement of the devices determined defective due to workmanship. No responsibility is assumed for possible omissions and inaccuracies. Circuitry and specifications are subject to change without notice. For the latest product specifications refer to the Supertex inc. (website: <http://www.supertex.com>)