

7068

Zweireihige SMT Stiftheiste RM 0,80 x 1,20mm Double Row SMT Pin Header 0,80 x 1.20mm Pitch

Technische Daten / Technical Data

Isolierkörper	Thermoplastischer Kunststoff, nach UL94 V-0
Insulator	Thermoplastic, rated UL94 V-0
Kontaktmaterial	Phosphorbronze
Contact Material	Phosphor bronze
Durchgangswiderstand	< 20mΩ
Contact Resistance	< 20mΩ
Isolationswiderstand	> 5GΩ
Insulation Resistance	> 5GΩ
Spannungsfestigkeit	500V _{AC}
Test Voltage	500V _{AC}
Nennstrom	1A
Current Rating	1A
Temperaturbereich	-65°C ... +125°C
Temperature Range	-65°C ... +125°C
Verarbeitung	Reflow-Lötverfahren; weitere Informationen in Kapitel T
Processing	Reflow-soldering, detailed information in ch. T

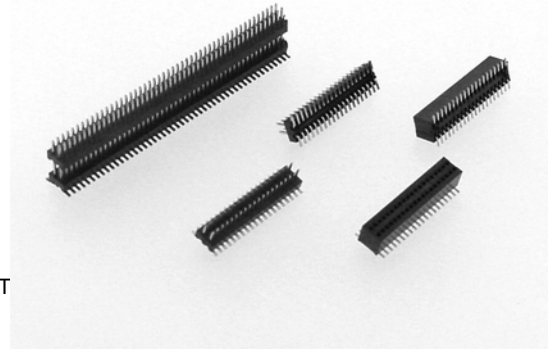

© W+P PRODUCTS

Passende Buchsenleiste: **7850**
Mates with female header **7850**

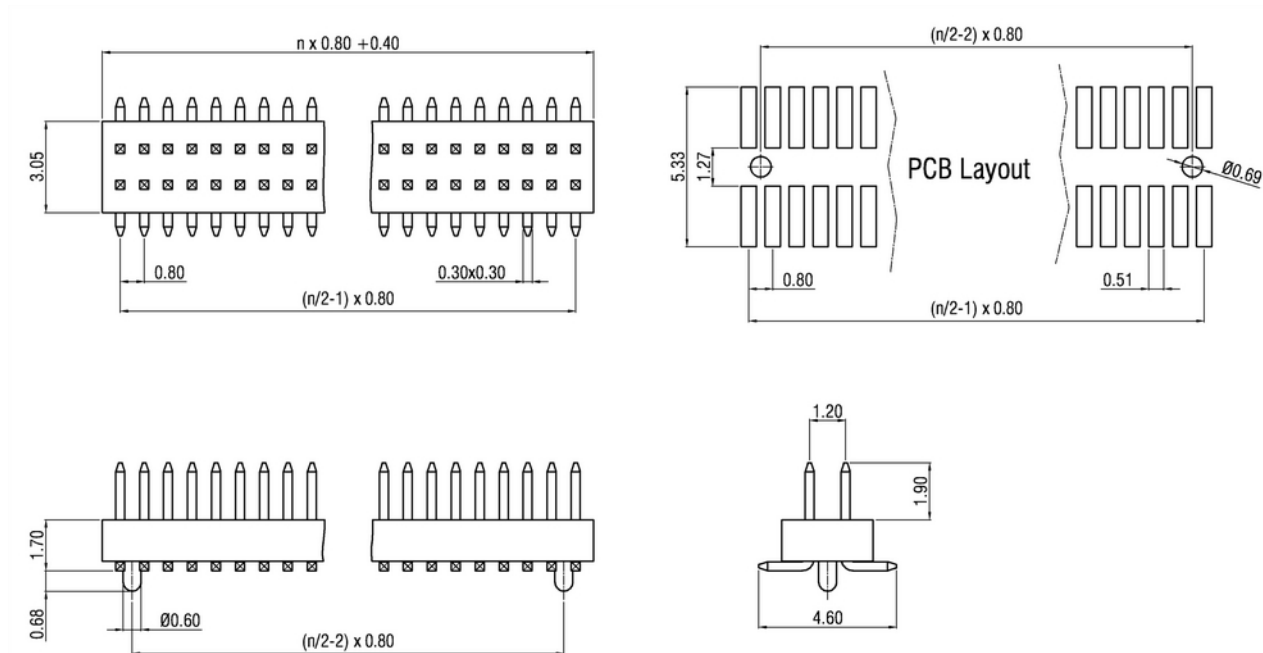

Series	Contacts*	Plating*	Locating Peg*	Packing*
7068	040 006-100	00 00 Vergoldet Gold plated 10 Au 0,25µm Au 0,25µm	10 00 Ohne Pos.Hilfe W/o pos. peg 10 Mit Pos.hilfe With pos. peg	PPST PPST PPTR

(* Bestellbeispiel - Bitte durch Ihre Spezifikationen ersetzen.
* Order example - To be replaced by your specifications.)

TEL.: +49 5223 98507-0
FAX.: +49 5223 98507-50

Lieferformen / Packing Options:

PPST = In Stangen mit PP-Pad / In tubes w/ PP-Pad
PPTR = Tape & Reel mit PP-Pad / Tape & Reel w/ PP-Pad

W+P PRODUCTS

E-MAIL: sales@wpro.com
INTERNET: www.wpro.com

Informationen zum Reflow-Lötverfahren

Reflow-Soldering Information

Reflow-Lötverfahren Reflow-Soldering

Bauteile sollten gemäß folgendem Temperatur-Profil in Anlehnung an die IPC/JEDEC J-STD-020C für bleifreies Löten im Reflowverfahren verarbeitet werden (Maximalwerte)

Profil Eigenschaft	Bleifreies Löten
Durchschnitts-Ramp-Up Rate ($T_{S_{max}}$ to T_p)	3°C / Sek. Max.
Vorheizen - Temperatur Min ($T_{S_{min}}$) - Temperatur Max ($T_{S_{max}}$) - Zeit ($t_{S_{min}}$ auf $t_{S_{max}}$)	150°C 200°C 60-180 Sekunden
Verbleiben oberhalb: - Temperatur (T_L) - Zeit (t_L)	217°C 60-180 Sekunden
Peak/Klassifizierung Temperatur (T_p)	260°C +/- 5°C
Zeit innerhalb von 5°C um die Peak-Temperatur (t_p)	20-40 Sekunden
Ramp-Down Rate	6°C / Sekunde max.
Zeit von 25°C bis zur Peak-Temperatur	8 Minuten max.

Items should be soldered according to IPC/JEDEC J-STD-020C temperature-profile for leadfree reflow-soldering (maximum values):

Profile Feature	PB-Free assembly
Average Ramp-Up Rate ($T_{S_{max}}$ to T_p)	3°C / second max.
Preheat - Temperature Min ($T_{S_{min}}$) - Temperature Max ($T_{S_{max}}$) - Time ($t_{S_{min}}$ auf $t_{S_{max}}$)	150°C 200°C 60-180 seconds
Time maintained above: - Temperature (T_L) - Time (t_L)	217°C 60-180 seconds
Peak/Classification Temperature (T_p)	260°C +/- 5°C
Time within 5°C of actual Peak-Temperature (t_p)	20-40 seconds
Ramp-Down Rate	6°C / second max.
Time 25°C to Peak Temperature	8 minutes max.

Empfohlenes Reflow-Lötprofil:

Recommended Reflow-Soldering profile:

