

# XMOS™



LED Reference Design Kit

## LED Reference Design Kit

The XMOS LED Reference Design builds on the power of XS1-G4 programmable devices and XC-3 LED Tile Controller card to demonstrate a complete LED tile system. All features and functions are implemented entirely in software using the XMOS Software Defined Silicon architecture. The LED Reference Design Kit includes:



XC-3 LED Tile Controller Card,  
5V Power Supply,  
XTAG Connector  
USB Cable

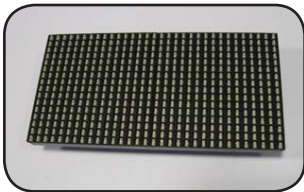

16x32 RGB LED



16-way Ribbon Cable



5V Power Supply

## Getting Started

The XC-3 card includes an implementation of the XMOS LED Reference Design software which provides native support for the MBI5030 Macroblock LED Driver IC. The application is designed to interface to an SMD-32X16-1R1G1G-F-P6, a 32x16 pixel LED module using 12 x MBI5030 on a 1/8 scan rate with a 16-way 2mm IDC connection.

The reference design software is pre-loaded on the XC-3. The latest version is available free of charge from: [www.xmos.com](http://www.xmos.com)

### Driving LEDs with the XC-3 Card

The LED application can be used out-of-the-box as a demonstration. A PC can be directly connected to the Ethernet daisychain, and a standard video player, such as the open-source *mplayer* application, can be used to broadcast video.

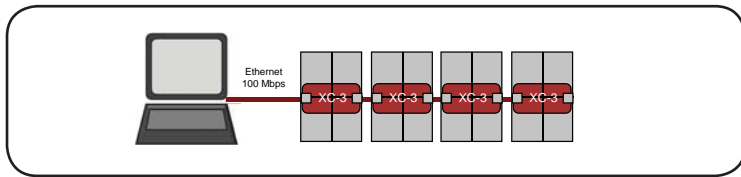

For large video wall systems a separate distribution or tiling unit is required, which inputs DVI, HDMI or VGA video at HD resolutions, separates the data for each of the tiles in the system, packetizes it and distributes over one or more gigabit Ethernet streams.

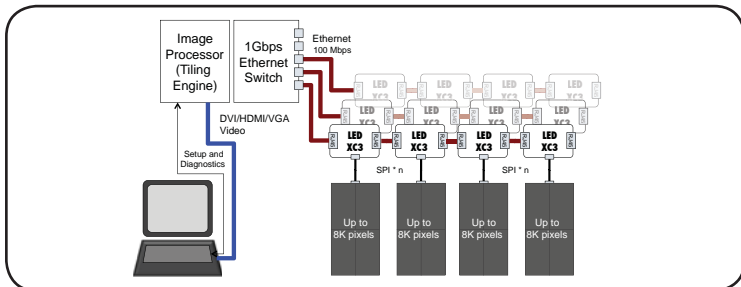

## Configuring a single board demonstration

1. Plug-in the XC-3 using the 5V power supply.

The PLL LED on the bottom of the board lights up to indicate that the board has been powered up.

2. Connect the XC-3 card to the LED module using the ribbon cable supplied. Connect the cable to the LED\_MOD\_OUT header on the XC-3 and the IN connector in the module.

The text "XMOS" is displayed.

3. Set the PC to use a static Ethernet IP address, with an IP of **192.168.0.1**, and a subnet mask of **255.255.0.0**.
4. Connect the PC to the XC-3 using an Ethernet cable (not supplied in kit).
5. Test connectivity by pinging the default IP address of the XC-3: **192.168.0.254**.
6. Use the *mplayer* application, supplied with the LED Reference Design software, to stream video to the tiles, with the following command:

```
mplayer -vf scale=16:32 -loop 0 -vo xudp:noinit:  
tilewidth=16:tileheight=32 videofile.avi
```

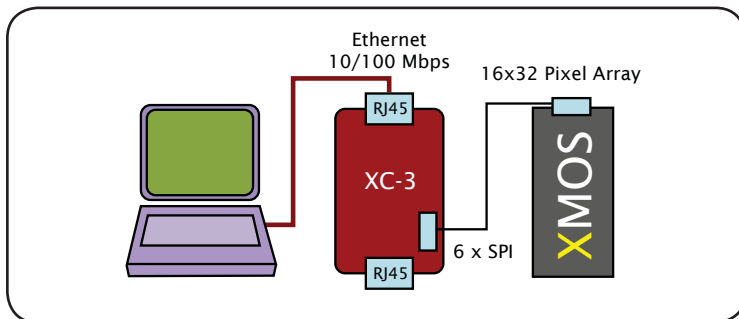

## Configuring a dual board demonstration

1. Follow Step 1 and Step 2 from the single-board demonstration.
2. Run the LED Tile Configuration Application with the following command:

```
ledconfig.exe --prefix=192.168 --port=306
```

3. In the application, run the command:

```
ac
```

The application acknowledges this with “Autoconfigure packets sent” message.

4. Quit the application by typing:

```
quit
```

The IP addresses for the LED modules are automatically configured.

5. Test connectivity with both tiles by pinging **192.168.1.1** and **192.168.1.2**.

6. Use the *mplayer* application, supplied with the LED Reference Design software, to stream video to the tiles, with the following command:

```
mplayer -vf scale=32:32 -loop 0 -vo xudp:  
tilewidth=16:tileheight=32:chainstart=0_0:  
chainpoint=1_0 videofile.avi
```

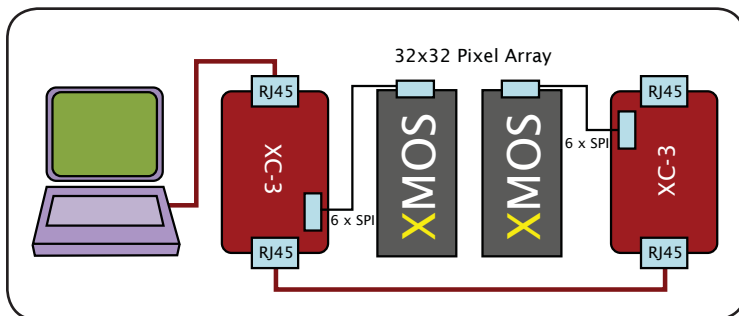

## Debugging the XC-3 Card

The LED Kit includes an XTAG connector and USB cable that can be used for loading and debugging programs on the XC-3 card via JTAG. You can connect the XTAG device to the XC-3 at anytime.

### Connect the XC-3 using a JTAG interface



Connect the XC-3 to the XTAG using the IDC connector.



Connect the XTAG to your development system using the USB cable.

When you are prompted to install the hardware drivers, follow the instructions on screen. You may have to install two hardware device and a serial port driver.

Once you have installed the drivers, you need to install the development tools which include utilities for loading programs onto the card (XRUN/XFLASH) and a port of the GNU debugger and utilities for loading programs onto the card.

## Install the software development tools

1. Download the software development tools from:

**[www.xmos.com/downloads](http://www.xmos.com/downloads)**

**NOTE:** You must use Development Tools version 9.2.2 (or later).

2. Run the Windows Installer to install the tools. Follow the instructions on screen.

The installer creates shortcuts to the XMOS Development Environment (a graphical development environment) and the XMOS Desktop Tools Prompt (command line tools).

3. Select Start>Programs>XMOS>Desktop Tools Prompt.
4. Type the following command:

```
xrun --listdevices
```

All the XMOS devices attached to your system are listed.

## Next Steps

Information on using the XC-3 and development tools is available from [www.xmos.com/xc3](http://www.xmos.com/xc3) including:

*LED Reference Design Application Note* - explains how to use the software installed on the XC-3

*XC-3 Hardware Manual* - hardware features on the XC-3 board

*Desktop Tools User Guide* - how to use the development tools

Further information on configuring the USB drivers and additional documentation is available from:

[www.xmos.com/support](http://www.xmos.com/support)

## XC-3 Card Features

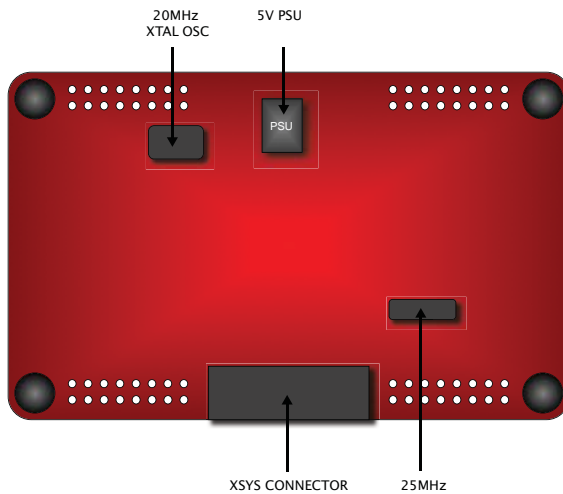
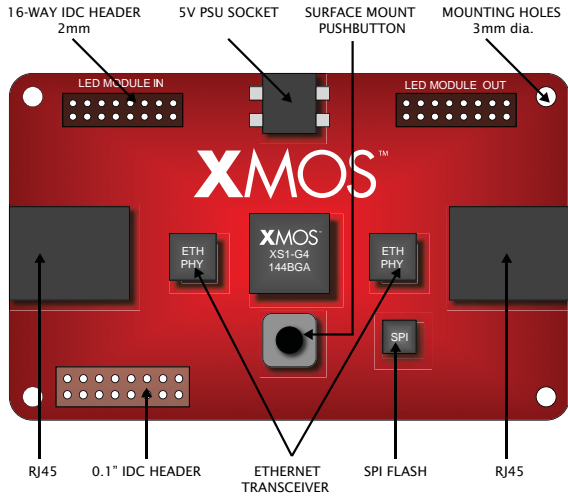

## Hardware Notice & Disclaimer

The following terms and conditions apply to the XMOS goods in your possession:

### Definition

'X MOS' means XMOS Limited

'Customer' means the person (legal or natural) to whom the Goods are supplied.

'Goods' means all hardware, software or services which are to be supplied to the Customer by XMOS under this Notice & Disclaimer.

### Warranty & Liability

1.1 Hardware will be free from defects in materials and workmanship for a period of 12 months from date of purchase. This warranty shall not apply to any defect, failure or damage caused by improper use or improper or inadequate maintenance or care of the hardware.

1.2 XMOS's obligations and liabilities in respect of the Goods shall be limited to those set out expressly herein and XMOS specifically excludes without limitation the implied conditions of satisfactory quality and fitness for any particular use or purpose. XMOS shall have no liability whatsoever in respect of any advice and/or information which may be given to the Customer by XMOS relating to Goods, their configuration or otherwise.

1.3 The Customer shall ensure that any warranty and maintenance service performed on Goods is performed by a qualified representative authorised by XMOS to offer warranty and maintenance on those Goods.

1.4 XMOS makes no representation and gives no warranty in respect of the sources of origin of manufacture or production of the Goods or any part thereof.

1.5 Without prejudice to Clause 1.1 and 1.2 in the event of XMOS being shown to have been negligent in the supply of Goods or the provision of services its liability:

1.5.1 for death or personal injury of any person caused by such negligence shall be unlimited.

1.5.2 in respect of any defects in or failure of hardware or for the loss or damage attributable thereto or to the negligence of its employees in connection with the performance of their duties hereunder, shall be limited to the making good by replacement or repair of such hardware which upon inspection by XMOS appear to be defective and in any event XMOS's maximum aggregate liability arising in respect of the supply of Goods or services shall be limited to the original VAT exclusive price for such Goods or services.

1.6 XMOS shall not in any circumstances whatsoever be liable for indirect or consequential loss including but not limited to loss of profits, revenue, business, contracts loss of data or use and shall have no liability for any claim based upon the combination operation or use of any Goods with equipment data or programming not supplied by XMOS or based upon a modification of the Goods.

1.7 Any action against XMOS must be brought no later than 12 months after the Customer becomes aware that a cause of action has arisen.

### Export and Restrictions on use

1.8 The Customer acknowledges that the Goods may be subject to US and local government export controls. Where these apply it is the Customer's sole responsibility to obtain authorisation from the appropriate authorities before reexporting the Goods from the country of purchase.

1.9 All Goods are manufactured for standard commercial uses and are not intended to be sold or licensed for use in critical safety/health systems or in nuclear facilities, other nuclear applications, mass transportation and aviation applications.

### Intellectual Property & General

1.10 The Customer recognises XMOS's and its licensors' ownership of and title to all trademarks, service marks, trade names, patents, copyright and other intellectual property rights comprised in the Goods and any accompanying materials.

1.11 The Customer will take no action to violate, obliterate, remove, alter, conceal or misuse any such marks, trade name or copyright notice.

1.12 The Customer will promptly notify XMOS if it becomes aware of any infringement of such intellectual property rights by any third party and shall provide its reasonable assistance to XMOS and/or the manufacturer in connection with any resultant proceedings.

1.13 These Conditions shall be construed according to the laws of England. The Customer and XMOS submit to the non-exclusive jurisdiction of the English Courts in connection with any dispute or proceedings arising out of any contract incorporating these Conditions.

© 2009 XMOS Limited. All Rights Reserved