

XS1-G4 DESCRIPTION

The XS1-G4 is the first member of the XS1-G family of Software Defined Silicon devices. The XS1-G family blends a powerful programmable fabric based on multi-threaded processors with a high-level programming language design flow. XMOS devices are general-purpose programmable chips and are used in a wide range of applications and systems. The XS1-G4 is ideally suited to applications such as Ethernet AV, networked audio, intelligent LED display controllers, network timekeeping and chip-level security applications.

The XS1-G4 device is based on the XMOS XCore™ processor tile. Each tile contains a 32bit processor, memory, I/O ports for communicating with external components and XLink™ channels for communicating with other XMOS chips. A high performance switch supports low latency and deterministic communication between the threads in each XCore. XCore tiles are unique in their direct support for concurrent processing (multi-threading), event handling, communication and timed input-output operations.

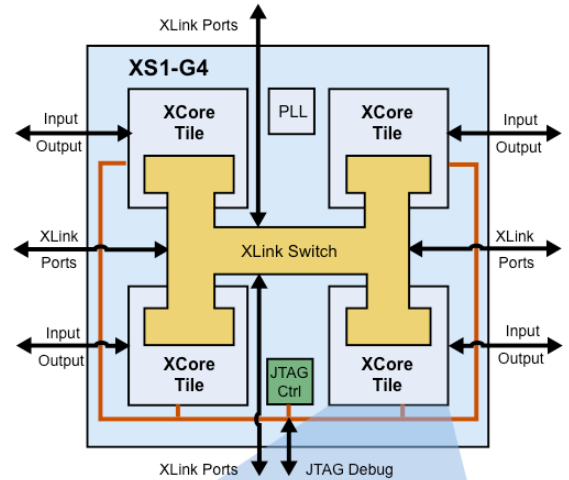

XS1-G4 KEY FEATURES

Performance

- Four XCore processor tiles providing 1600MIPs and up to 32 concurrent, deterministic real-time tasks
- Single-cycle context switch between threads; each thread has
 - Access to 16 dedicated registers, enabling threads to operate as unique logical cores
 - Guaranteed hard real-time performance regardless of the state of other threads
 - 32 x 32 → 64bit MAC providing high performance DSP and cryptographic functions

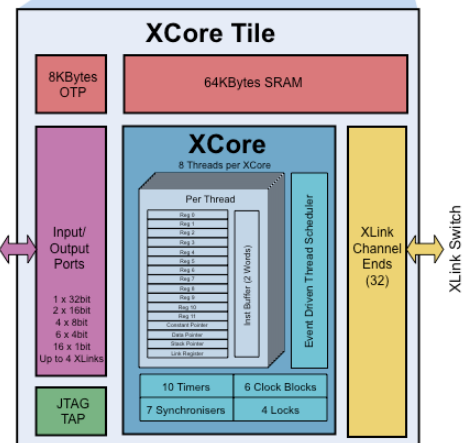

Responsiveness

- Up to 64 input/output pins (per XCore tile) that can be dynamically configured as input, output or bi-directional
- Each port provides 10ns timing resolution for precise interfacing
- Next-cycle event servicing from pins, communications or timers

Ease of use

- Designs implemented using a software-based design flow that eliminates iterative logic synthesis and timing closure
- XMOS-originated XC language extends C to support parallelism and real-time control
- Compact 16/32bit instruction set designed for efficient targeting from high-level language compilers
- 32 XLink channel ends (per XCore tile) for scalable communication with other threads, on or off-chip
- 64KB single-cycle unified SRAM (per XCore tile) for code and data storage

Security

- 8KB of OTP memory for application boot code and security keys
- Secure mode that disables debug and prevents readback of memory contents
- Eliminates need for external configuration memory in some applications

XS1-G FAMILY MEMBERS

Product	XCore Tiles	Threads	Memory (KB)		Package	User I/O	Availability	
			RAM	OTP				
XS1-G1	1	8	64	8			ES samples	1H2009
XS1-G2	2	16	128	16			ES samples	1H2009
XS1-G4	4	32	256	32	144BGA 11 x 11mm	88	ES samples Production ⁽¹⁾	Oct 2008 Nov 2008
					512BGA 20 x 20mm	256	ES samples Production ⁽¹⁾	Sep 2008 Oct 2008

Note 1: Pre-qualification production. Full qualification will be complete in 1H 2009.

DEVELOPMENT ENVIRONMENT

The XS1-G family is supported by a web-based design tool suite – a comprehensive set of development tools including compilers, a simulator, visualisation tools and an in-circuit debugger. Applications can be written in a combination of standard C and the XMOS originated XC.

The coupling of an embedded software flow with powerful debug tools means that hardware and software debug cycle times can now be measured in seconds.

XS1-G DEVELOPMENT KIT

To accelerate application design cycles XMOS has developed the XS1-G Development Kit (XDK). The XDK provides a complete development environment including a fully featured hardware platform, access to the web-based development tools, example code and educational tutorials.

XDK features:

- XS1-G4 target device
- QVGA touch screen display
- RJ45 10/100 Ethernet port
- SD card slot (card included)
- High-performance stereo audio port (input and output)
- JTAG programming interface
- XLink expansion ports
- User-assignable soft-keys and status LEDs
- Two IDC expansion headers for hardware development

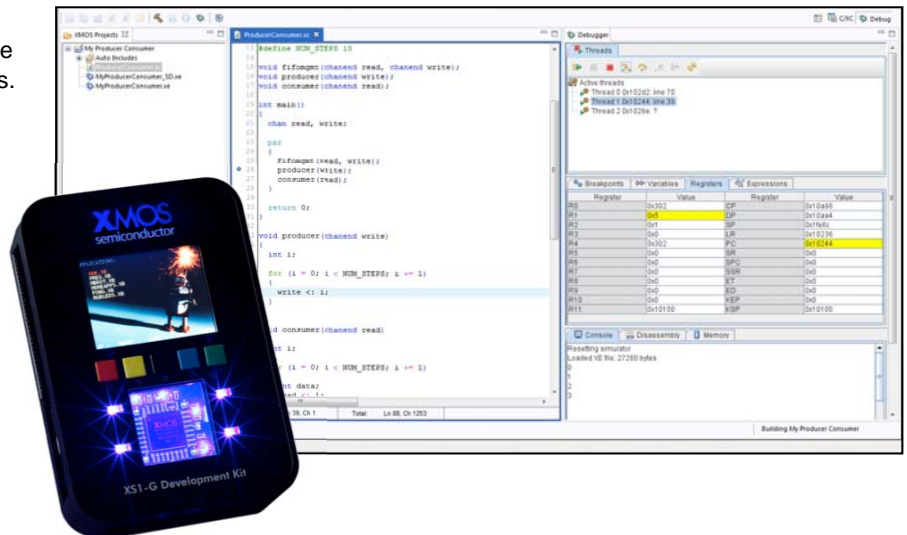

For more information about XMOS or our products, to purchase an XDK Development Kit, or to explore our web-based development tools, please visit our homepage or contact your local XMOS sales representative. Latest product data including specifications and availability are available at www.xmos.com.