



SiRes Oscillators are suitable for:

- Audio/Video
- Office Automation
- Automotive Applications
- Industrial Applications

These highly reliable oscillators are completely Quartz free.



Features

Standard Oscillator (resonator + drive circuit = oscillator) features

- One time programmable 1-125 MHz clock
- Compare to quartz oscillators and resonators in industry standard footprints
- +/- 50 ppm, +/-100 ppm options
- 20 ps rms jitter, +/- 100 ps peak to peak jitter at 100 MHz
- Output enable or Standby programmable option pin

Experience MEMS Benefits as compared to competitive quartz products

- No load capacitors or shunt resistors required for

operation

- Always in stock, MEMS resonators are manufacturing in 3 weeks in lot sizes of 1 million units vs. 12 weeks for quartz in lot sizes of 30K.
- Improved manufacturing performance with greater tolerance to shock, vibration, and thermal events to eliminate resonator cracking or permanent shifts in frequency.
- Ultra reliable start up
- Simplifies layout requirements with better immunity to interfering nearby PCB signals and no requirement to be near clock destination.

- Better immunity to electrostatic discharge
- Maximum 1 ppm first year aging
- Typical +/- 0.150 ppm / year aging in packaging, to 25 years.
- Standard plastic QFN-type packaging
 - 2.0mm x 2.5mm x 0.85mm
 - 3.2mm x 2.5mm x 0.85mm
 - 5.0mm x 3.2mm x 0.85mm
 - 7.0mm x 3.2mm x 0.85mm
- 1.8 V, 2.5 V or 3.3 V operation

Description

The SiRes SiT8002 oscillator family is the smallest, high-performance oscillator suitable for use in clock generation for consumer, portable, industrial, automotive, and computation applications.

This oscillator family is packaged in standard low-cost plastic QFN-type IC packages with footprints that match common quartz surface mount products.

MEMS-based (mechanical structures etched onto a silicon wafer) oscillators and resonators have been the dream of many researchers due to excellent performance, reliability, and small size in the laboratory. However, frequency stability and

packaging cost were barriers to commercial introduction until SiTime founders invented the EpiSeal[™] and MEMS First[™].

MEMS resonators are 1000x smaller by volume than quartz resonators and are built in high volume CMOS fabs instead of small custom manufacturing facilities. Due to their small size, massive lots sizes, and simpler manufacturing processes MEMS oscillators are inherently more reliable, have more consistent performance and are always in stock.

Learn more about MEMS oscillators at www.sitime.com

Block Diagram

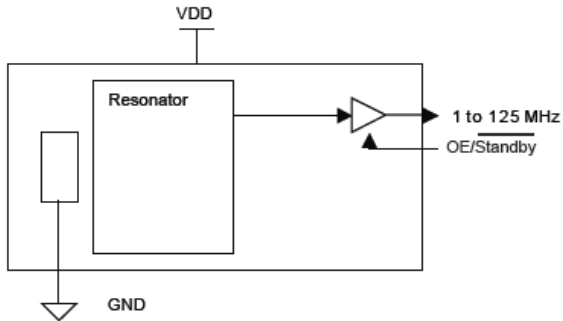

Package Thermal Characteristics

Theta JA = 30°C/W with copper plane on VDD and GND

Theta JA = 120°C/W with PCB traces of 0.010" to all pins

Pin Description

Pin Number	Pin Name	Pin Type	Pin Description
1	OE/ST	Digital In	Output Enable/Standby
2	GND	Power	Connect to Ground
3	CLK	Digital Out	Clock Output
4	VDD	Power	Connect 1.8V, 2.5V, 3.3V

External Component Selection

Series Termination Resistor

To avoid clock reflections on a 50 ohm PCB trace place a series termination resistor in series with the clock output when the PCB trace is greater than 2 inches. A 33 ohm resistor is usually sufficient. The maximum load capacitance is 15pF.

Decoupling Capacitor

A 0.1uF capacitor is recommended to be placed as close as possible to the VDD GND pins on the part. PCB traces should not be routed through vias. Only one decoupling capacitor is recommended per part.

Absolute Maximum Ratings

Attempted operation outside the absolute maximum ratings of the part may cause permanent damage to the part. Actual performance of the IC is only guaranteed within the operational specifications not absolute maximum ratings.

Parameter	Min	Max	Unit
Storage Temperature	-65	150	°C
Commercial Operation Temperature "C"	0	70	°C
Industrial Operation Temperature "I"	-40	85	°C
Automotive Operation Temperature (contact SiTime or SiTime sales representative for product in this temperature range)	-40	125	°C
VDD	-0.5	+3.6	V
Electrostatic Discharge, Human Body Model		4000	V
Latch UP per JEDEC 17		200	mA
Output Short Circuit	-40	40	mA

DC Electrical Specifications

The following specification apply at 1.8V +/- 0.1V, 0 to 70 °C

Parameter	Condition	Min	Typical	Max	Unit
Operating VDD		1.7		1.98	V
Voltage Output High	25 mA load current	70% of Vdd			V
Voltage Output Low	10 mA source current			30% of Vdd	V
Operating Current Consumption	at 60 MHz, 15 pF			19	mA
Standby Current Consumption	Output is weakly pulled down		30	50	uA

The following specification apply at 3.3V +/- 0.3V, 0 to 70 °C

Parameter	Condition	Min	Typical	Max	Unit
Operating VDD		3.0		3.6	V
Voltage Output High	25 mA load current	70% of Vdd			V
Voltage Output Low	10 mA source current			30% of Vdd	V
Operating Current Consumption	at 60 MHz, 15 pF			19	mA
Power Down Current Consumption			30	50	uA

AC Electrical Specifications

The following specification apply at 3.3V +/- 10%, 0 to 70° C

Parameter	Condition	Min	Typical	Max	Unit
Clock Output Frequency		1		125	MHz
Frequency Drift over temperature	SiT8002Ax-x3-33S-T			+/-50	ppm
	SiT8002Ax-x4-33S-T			+/-100	ppm
Aging	1st year			1	ppm
Clock Output Duty Cycle		45	50	55	%
Clock Output Rise Time	15 pF			2	ns
Clock Output Fall Time	15 pF			2	ns
Period Jitter pk-pk	At 24 MHz		+/-200		ps
Period Jitter pk-pk	At 100 MHz		+/-100		ps
Start up time				10	ms
VDD Ramp Time		0		200	ms

SIT8002AC-14-33S-123.12345T

Part Family: "SIT8002"	Temperature Range "C" -10 to 70°C "I" -40 to 85°C	Package Size: "1" 2.5 x 2.0 mm "2" 3.2 x 2.5 mm "3" 5.0 x 3.2 mm "4" 7.0 x 5.0 mm	Frequency Tolerance: "3" +/- 50 ppm "4" +/- 100 ppm	Voltage Supply: "18" 1.8V +/- 0.1V "25" 2.5V +/- 0.2V "33" 3.3V +/- 0.3V	Optional Pin Function: "E" for Output Enable "S" for Standby	Frequency (1 - 125 MHz): e.g. 14.31818 e.g. 125.000	Package: "T" for Tape & Reel
----------------------------------	--	--	--	--	---	--	--

Package Information

2.5 mm x 2.0 mm x 0.85 mm QFN type package

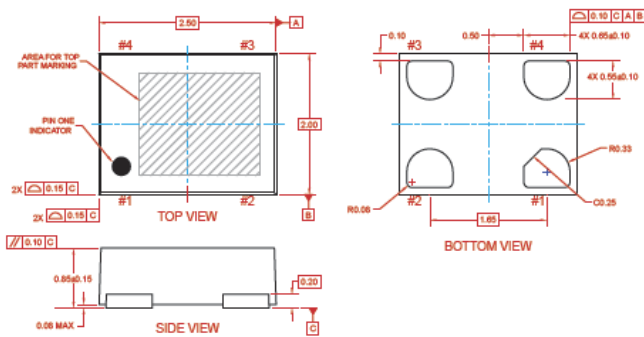

3.2 mm x 2.5 mm x 0.85 mm QFN type package

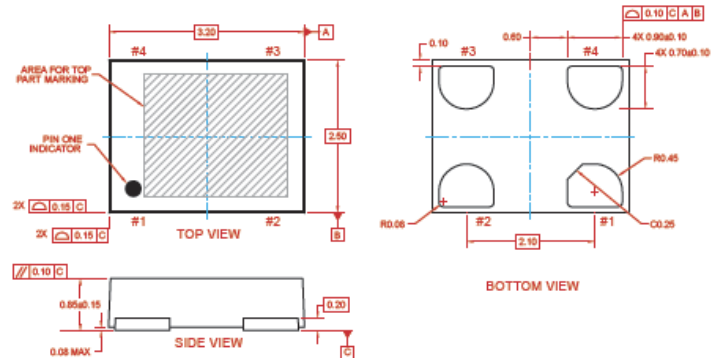

5.0 mm x 3.2 mm x 0.85 mm QFN type package

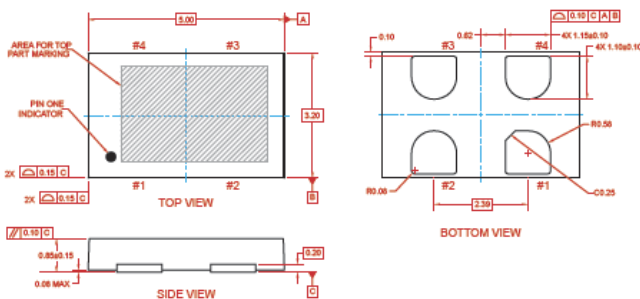

7.0 mm x 5.0 mm x 0.85 mm QFN type package

